



DSPE*G*

PROPORTIONAL DIRECTIONAL VALVES, PILOT OPERATED WITH INTEGRATED ELECTRONICS

SUBPLATE MOUNTING

- DSPE5G* CETOP P05
- DSPE5RG* ISO 4401-05
- DSPE7G* ISO 4401-07
- DSPE8G* ISO 4401-08
- DSPE10G* ISO 4401-10
- DSPE11G* ISO 4401-10 oversize ports

OPERATING PRINCIPLE

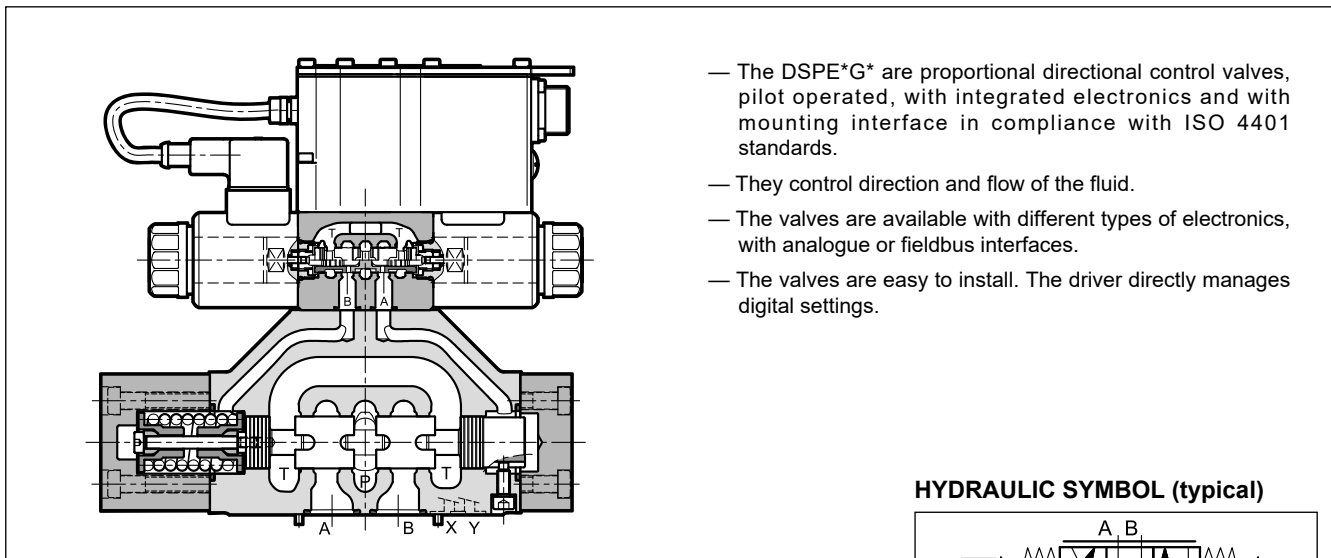

- The DSPE*G* are proportional directional control valves, pilot operated, with integrated electronics and with mounting interface in compliance with ISO 4401 standards.
- They control direction and flow of the fluid.
- The valves are available with different types of electronics, with analogue or fieldbus interfaces.
- The valves are easy to install. The driver directly manages digital settings.

HYDRAULIC SYMBOL (typical)

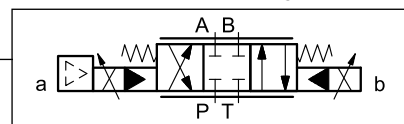

PERFORMANCES

(obtained with mineral oil with viscosity of 36 cSt at 50°C and p = 140 bar)

		DSPE5G* DSPE5RG*	DSPE7G*	DSPE8G*	DSPE10G*	DSPE11G*
Max operating pressure: P - A - B ports T port	bar	350 see point 10				320 see p. 10
Max flowrate	l/min	180	450	800	1800	2000
Hysteresis	% Q max	< 6 %				
Repeatability	% Q max	< ± 1 %				
Electrical characteristics		see point 4				
Ambient temperature range	°C	-20 / +60				
Fluid temperature range	°C	-20 / +80				
Fluid viscosity range	cSt	10 ÷ 400				
Fluid contamination degree		According to ISO 4406:1999 class 18/16/13				
Recommended viscosity	cSt	25				
Mass	kg	7.3	8.2	16.4	44.1	41.3



1 - IDENTIFICATION CODES

1.1 - Standard electronics

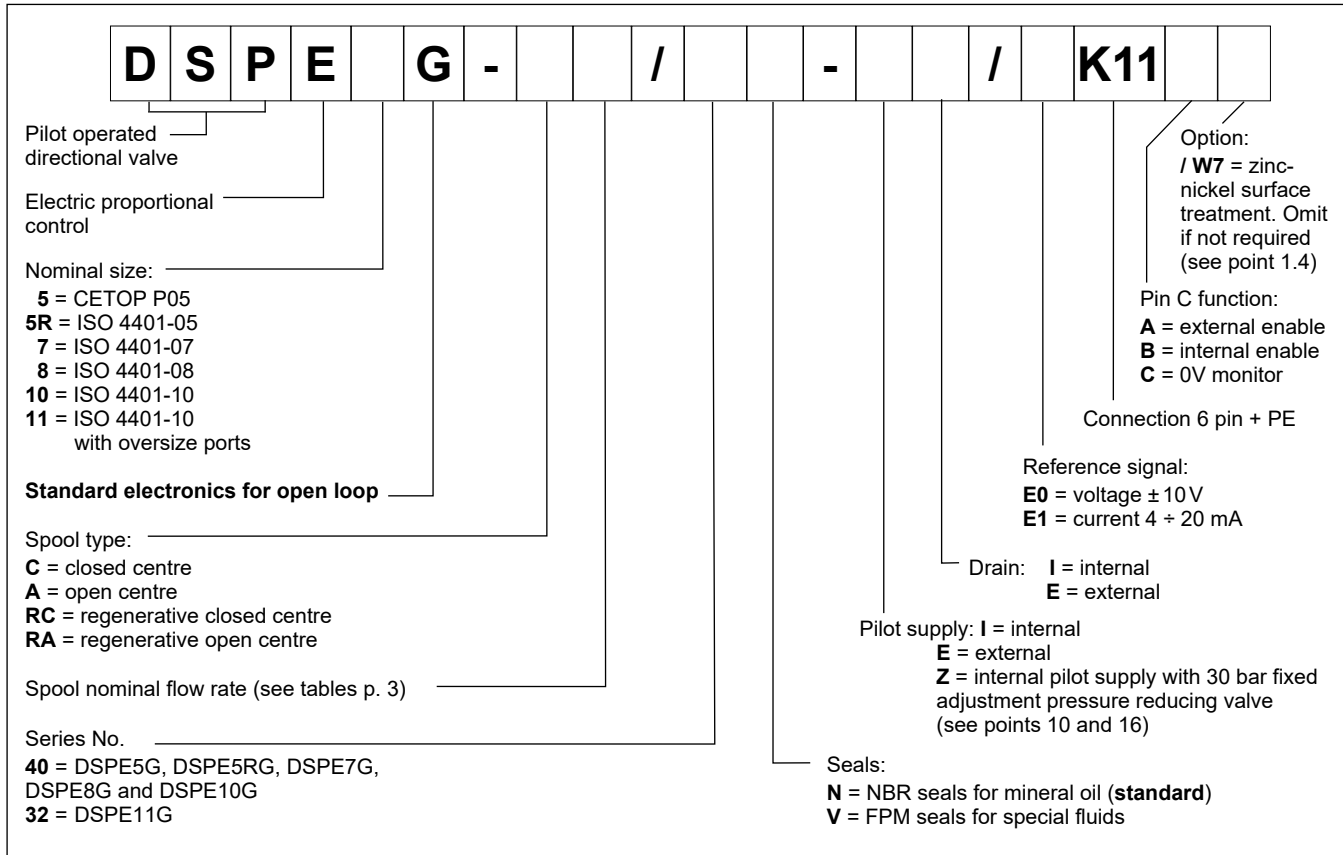

1.2 - Compact electronics

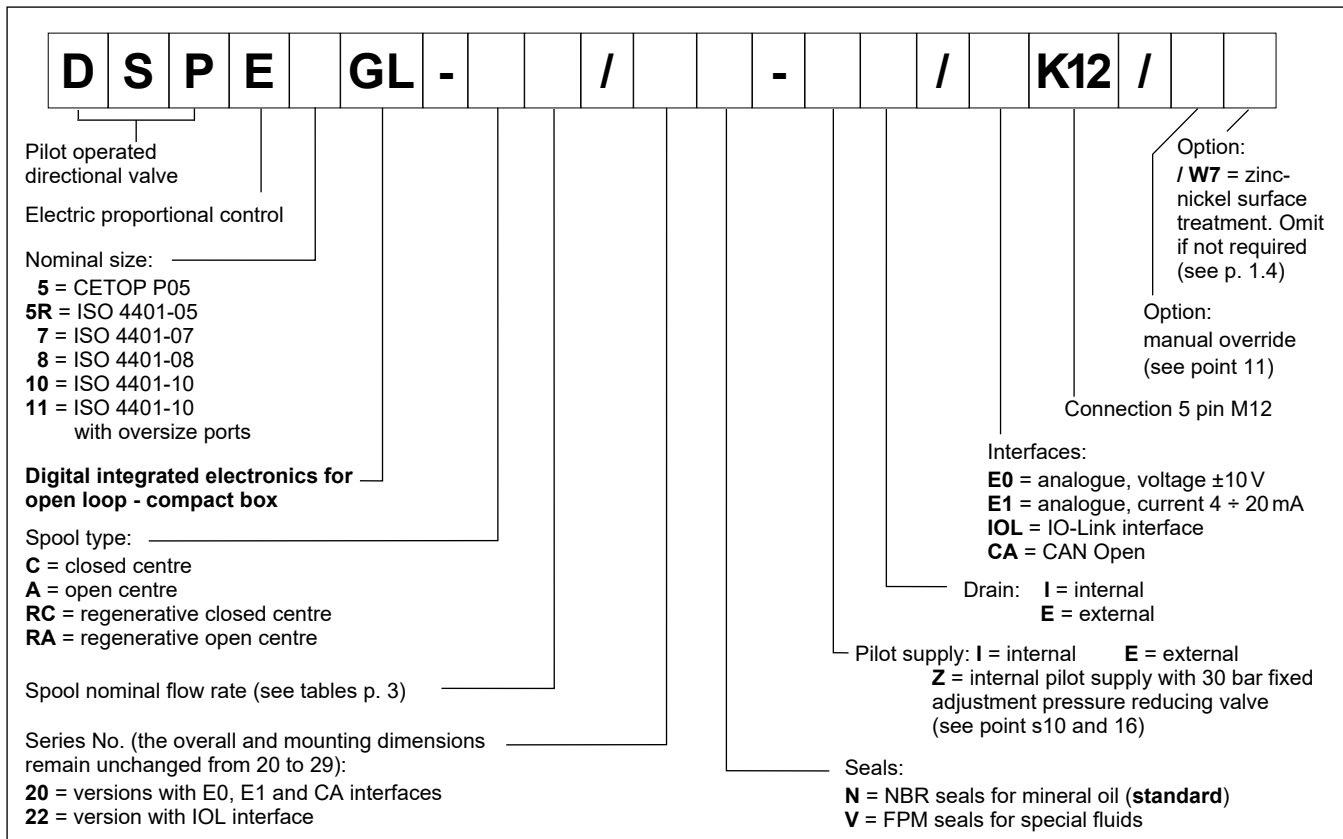

1.3 - Electronics with fieldbus communication

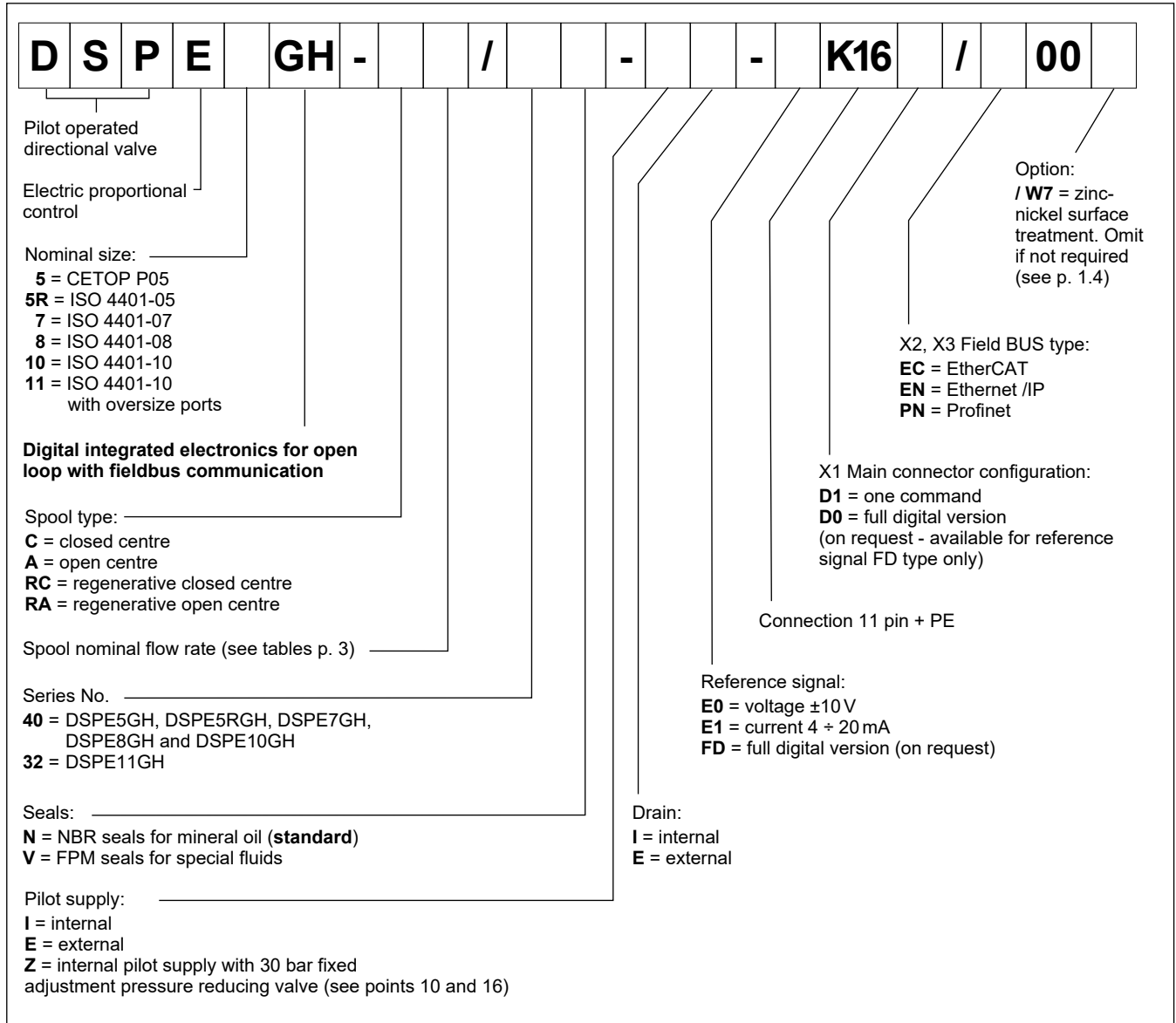

1.4 - Surface treatments

The standard valve is supplied with surface treatment of phosphating black. The zinc-nickel finishing makes the valve suitable to ensure a salt spray resistance up to 240 hours. (test operated according to UNI EN ISO 9227 standards and test evaluation operated according to UNI EN ISO 10289 standards).

2 - COMPARISON AMONG INTEGRATED ELECTRONICS

G type **GL type** **GH type**

Dimensions: G type (96 mm), GL type (77 mm), GH type (134 mm).

Callouts: 1 (top connector), 2 (middle connector), X1 (top connector), X2 (middle connector), X3 (middle connector).

dimensions in mm

1	Connection 6 pin + PE
2	Connection M12 5 pin, code A, male
X1	Main connection 11 pin + PE
X2	Fieldbus communication (IN)
X3	Fieldbus communication (OUT)

NOTE 1: Please refer to section 7 for connections descriptions and pinouts.
NOTE 2: Related mating connectors have to be ordered separately. See catalogue 89 000.

3 - AVAILABLE CONFIGURATIONS

The valve configuration depends on the combination of spool type and rated flow.

3 positions with spring centering

regenerative spool

valve type	*	Nominal flow with Δp 10 bar P→T
DSPE5G* DSPE5RG*	80	80 l/min
	80/40	80 (P-A) / 40 (B-T) l/min
DSPE7G*	100	100 l/min
	150	150 l/min
	150/75	150 (P-A) / 75 (B-T) l/min
DSPE8G*	200	200 l/min
	300	300 l/min
	300/150	300 (P-A) / 150 (B-T) l/min
DSPE10G*	350	350 l/min
	500	500 l/min
	500/250	500 (P-A) / 250 (B-T) l/min
	800	800 l/min
	800/500	800 (P-A) / 500 (B-T) l/min
DSPE11G*	1000	1000 l/min

Type of valve	*	Nominal flow with Δp 10 bar P→T
DSPE7G*	150/75	150 (P-A, A-T) / 75 (P-B, B-P) l/min
DSPE8G*	300/150	300 (P-A, A-T) / 150 (P-B, B-P) l/min
DSPE10G*	500/250	500 (P-A, A-T) / 250 (P-B, B-P) l/min

4 - ELECTRONICS COMMON DATA

Duty cycle		100% (continuous operation)
Protection class according to EN 60529 (NOTE): DSPE*G, DSPE*GH DSPE*GL		IP65/IP67 IP65
Supply voltage	V DC	24 (from 19 to 30 VDC), ripple max 3 Vpp
Power consumption	VA	25
Maximum solenoid current	A	1.88
Fuse protection, external	A	3
Managed breakdowns		Overload and electronics overheating, cable breakdown, supply voltage failures
Electromagnetic compatibility (EMC) emissions EN 61000-6-4, immunity EN 61000-6-2		According to 2014/30/EU standards

NOTE: The IP degree is guaranteed only with mating connector of equivalent IP degree, installed and tightened correctly. Moreover, on the GH versions it is necessary to protect any unused connections with caps.

5 - DSPE*G - STANDARD ELECTRONICS

5.1 - Electrical characteristics

Command signal:	voltage (E0) current (E1)	V DC mA	± 10 (Impedance $R_i > 11 \text{ kohm}$) $4 \div 20$ (Impedance $R_i = 58 \text{ ohm}$)
Monitor signal:	voltage (E0) current (E1)	V DC mA	± 10 (Impedance $R_o > 1 \text{ kohm}$) $4 \div 20$ (Impedance $R_o = 500 \text{ ohm}$)
Communication for diagnostic			LIN-bus Interface (by means of the optional kit)
Connection			6 pin + PE (MIL-C-5015-G - DIN EN 175201-804)

5.2 - On-board electronics diagrams

VERSION A - External Enable

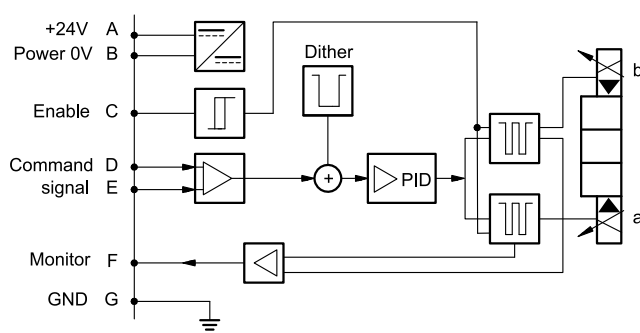

VERSION B - Internal Enable

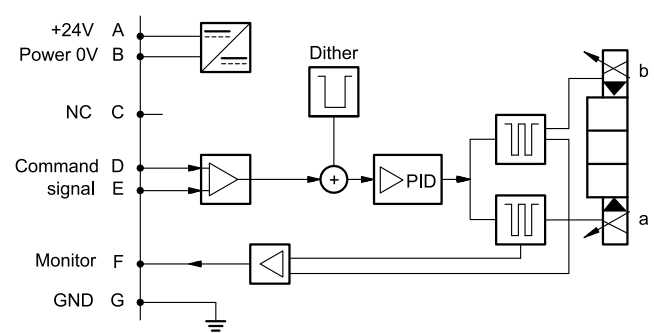

VERSION C - 0V Monitor

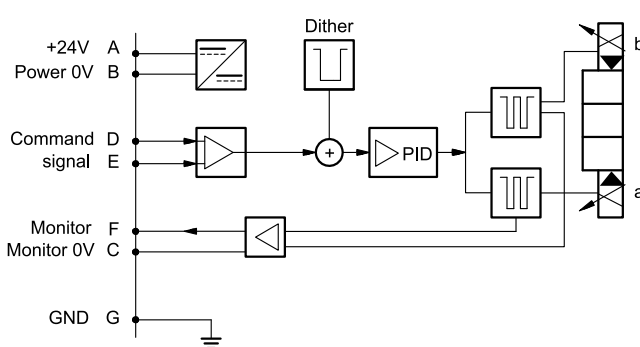

5.3 - Versions with voltage command (E0)

The reference signal is between -10V and +10V. The monitor feature of versions B and C becomes available with a delay of 0,5 sec from the power-on of the card.

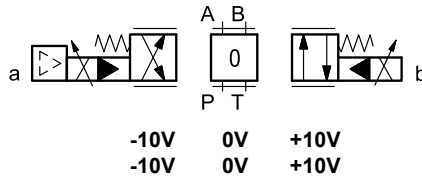

COMMAND
MONITOR

-10V 0V +10V
-10V 0V +10V

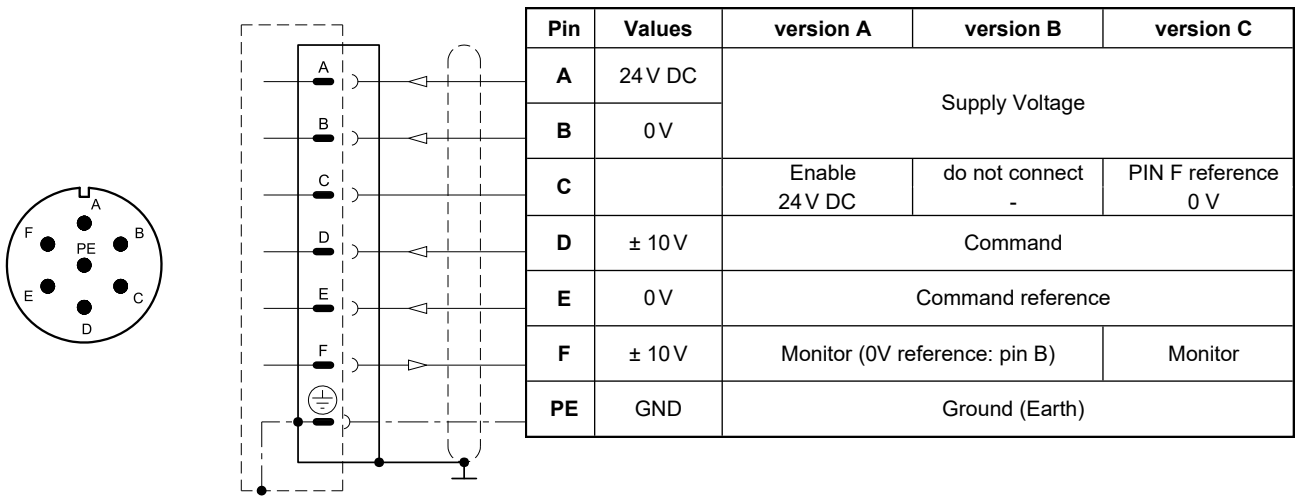

5.4 - Versions with current command (E1)

The reference signal is supplied in current $4 \div 20$ mA. If the current for command is lower the card shows a breakdown cable error. To reset the error is sufficient to restore the signal.

The monitor feature of versions B and C becomes available with a delay of 0,5 sec from the power-on of the card.

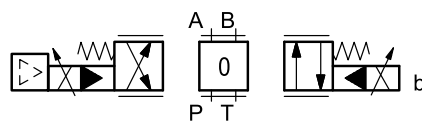

COMMAND
MONITOR

4 mA 12 mA 20 mA
4 mA 12 mA 20 mA

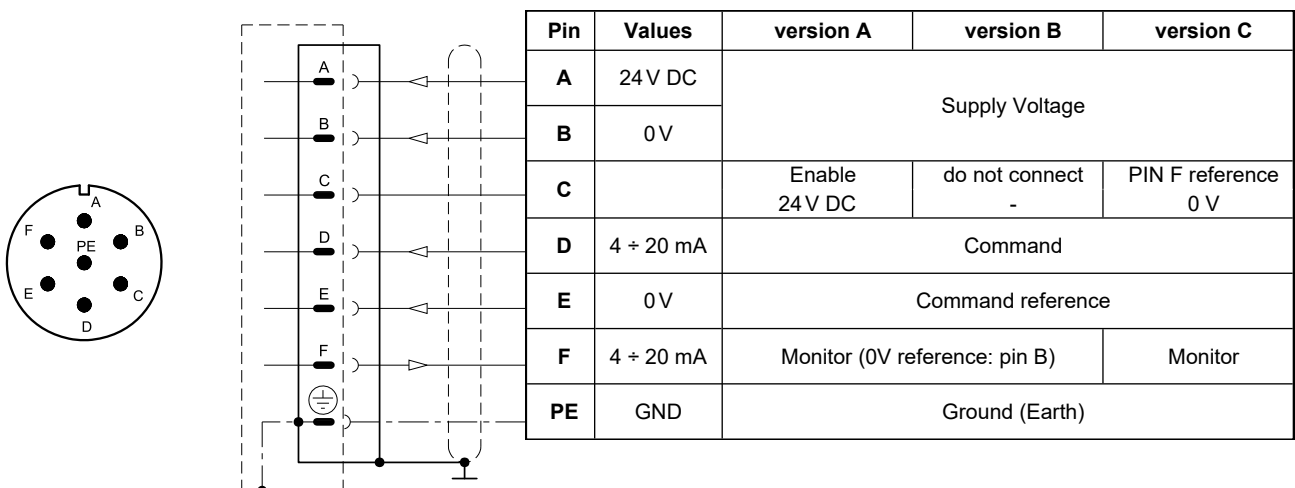

6 - DSPE*GL - COMPACT ELECTRONICS

In IO-Link networks, the length of the connecting cables is limited to 20 metres. In CA versions, pin 3 and pin 5 are galvanic isolated up to 100 V to avoid earth loops.

6.1 - Electrical characteristics

Command signal:	voltage (E0) current (E1)	V DC mA	± 10 (impedance $R_i > 11 \text{ kohm}$) $4 \div 20$ (impedance $R_i = 58 \text{ ohm}$)
Monitor signal :	voltage (E0) current (E1)	V DC mA	$0 \div 5$ (impedance $R_o > 1 \text{ kohm}$) $4 \div 20$ (impedance $R_o = 500 \text{ ohm}$)
IO-Link communication (IOL): Data rate		kBaud	IO-Link Port Class B 38.4
Can Open communication (CA): Data rate		kbit	$10 \div 1000$
Data register (IOL and CA versions only)			card voltage supply, solenoid faults (shortcircuit, bad configuration), box temperature.
Connection			5-pin M12 code A (IEC 61076-2-101)

6.2 - Pin tables

'E0' connection

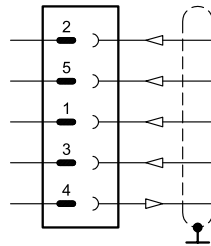

Pin	Values	Function
2	24 V DC	Supply voltage (solenoid and logic)
5	0 V	
1	± 10 V	Command
3	0V	Command reference
4	$0 \div 5$ V	Monitor (0V reference: pin 5)

'E1' connection

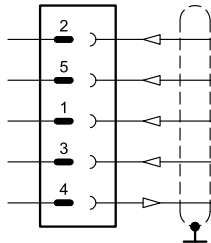

Pin	Values	Function
2	24 V DC	Supply voltage (solenoid and logic)
5	0 V	
1	$4 \div 20$ mA	Command
3	0V	Command reference
4	$4 \div 20$ mA	Monitor (0V reference: pin 5)

'IOL' connection

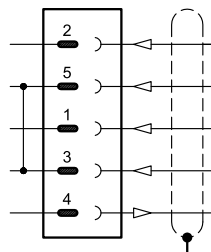

Pin	Values	Function
2	2L+ 24 V DC	Solenoid supply voltage
5	2L- 0V (GND)	
1	1L+ +24 V DC	Logic and IO-Link supply voltage
3	1L- 0V (GND)	
4	C/Q	IO-Link Communication

NOTE: Pin 3 and pin 5 are linked with each other in the valve electronics. The reference potentials 1L- and 2L- of the two supply voltages must also be linked with each other on the customer side.

'CA' connection

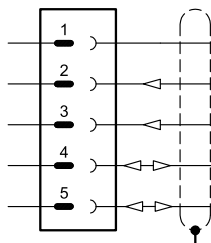

Pin	Values	Function
1	CAN_SH	Shield
2	24 V DC	Supply voltage
3	0V (GND)	
4	CAN H	Bus line (high)
5	CAN_L	Bus line (low)

7 - DSPE*GH - FIELD BUS ELECTRONICS

The 11 + PE pin connection allows separate supply voltage for electronics and solenoids.

Command - valve position schemes as for the standard electronics. Please refer to pictures in p. 5.3 and 5.4.

7.1 - Electrical characteristics

Command signal:	voltage (E0) current (E1) digital (FD)	V DC mA	± 10 (Impedance $R_i > 11 \text{ kohm}$) $4 \div 20$ (Impedance $R_i = 58 \text{ ohm}$) via fieldbus
Monitor signal (current to solenoid):	voltage (E0) current (E1)	V DC mA	± 10 (Impedance $R_o > 1 \text{ kohm}$) $4 \div 20$ (Impedance $R_o = 500 \text{ ohm}$)
Communication / diagnostic			via Bus register
Communication interface standards			IEC 61158
Communication physical layer			fast ethernet, insulated 100 Base TX
Power connection			11 pin + PE (DIN 43651)

7.2 - X1 Main connection pin table

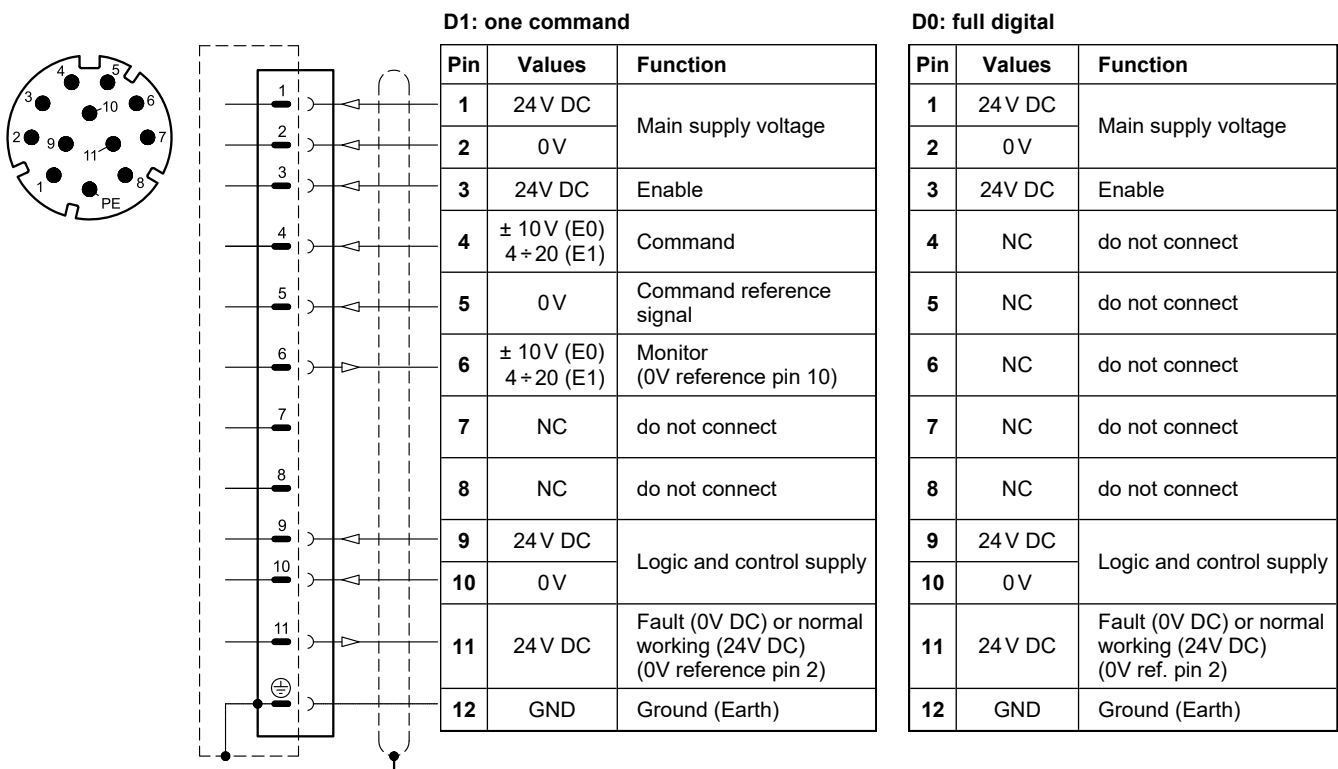

7.3 - FIELD BUS connections

Please wire following guidelines provided by the related standards communication protocol. Any connections present and not used must be protected with special caps so as not to nullify the protection against atmospheric agents.

X2 (IN) connection M12 D 4 pin female



Pin	Values	Function
1	TX+	Transmitter
2	RX+	Receiver
3	TX-	Transmitter
4	RX-	Receiver
HOUSING	shield	

X3 (OUT) connection: M12 D 4 pin female



Pin	Values	Function
1	TX+	Transmitter
2	RX+	Receiver
3	TX-	Transmitter
4	RX-	Receiver
HOUSING	shield	

NOTE: Shield connection on connector housing is recommended.



8 - CHARACTERISTIC CURVES

(obtained with mineral oil with viscosity of 36 cSt at 50°C and $p = 140$ bar)

Typical flow rate curves at constant Δp related to the reference signal and measured for the available spools. The Δp values are measured between P and T valve ports.

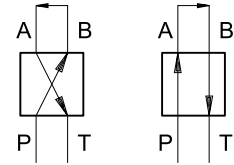

8.1 - Characteristic curves DSPE5G* and DSPE5RG*

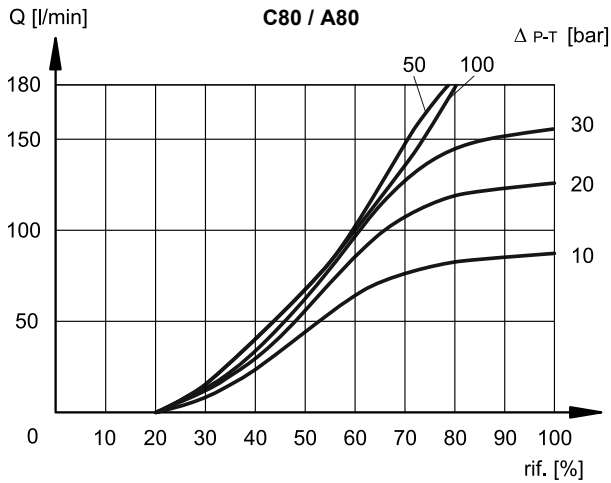

8.2 - Characteristic curves DSPE7G*

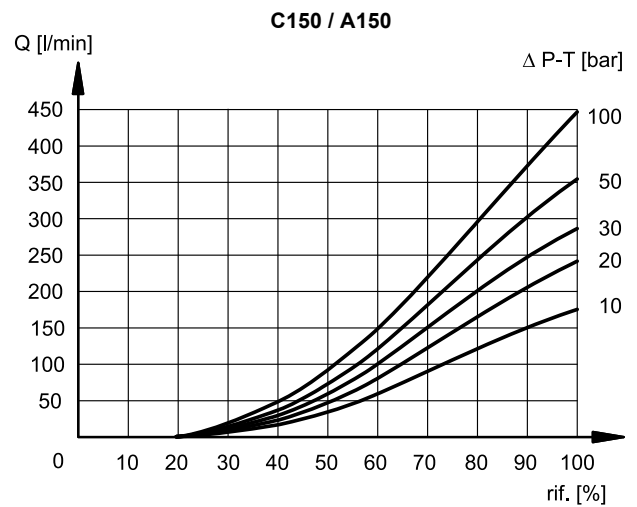
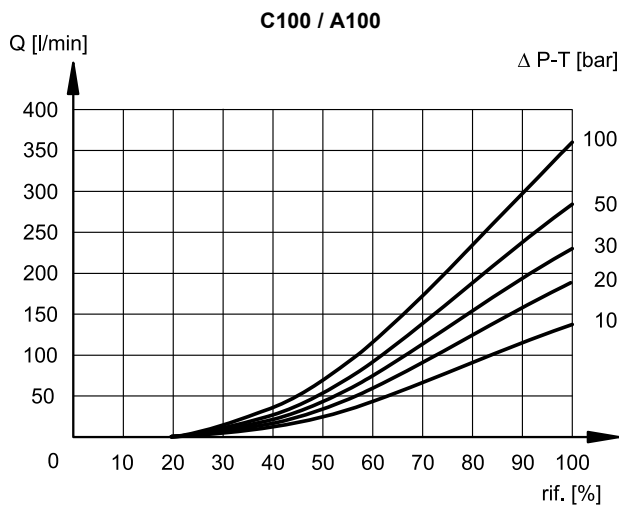

8.3 - Characteristic curves DSPE8G*

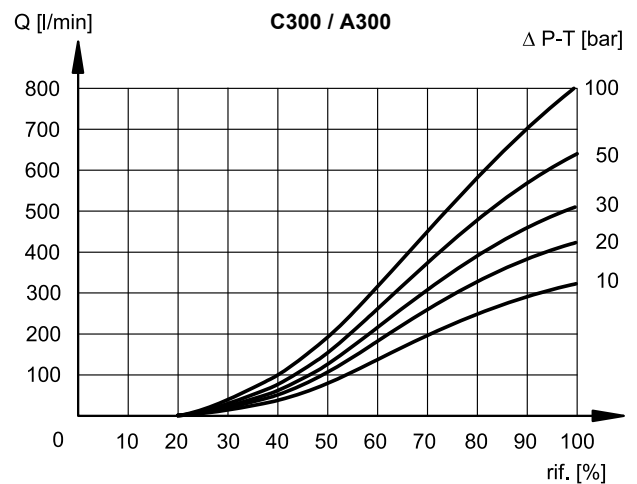
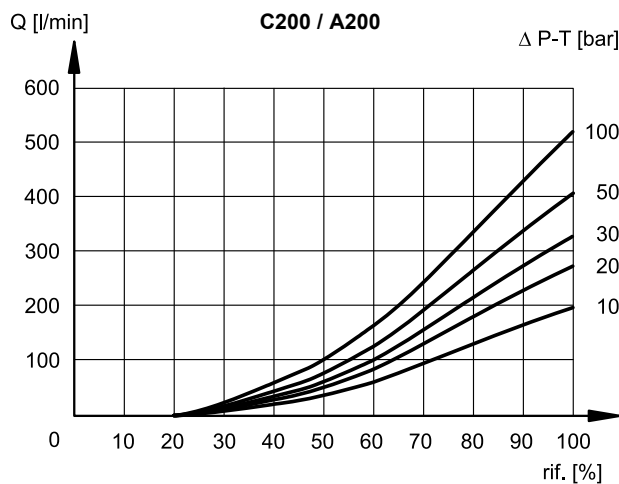



8.4 - Characteristic curves DSPE10G*

C350 / A350

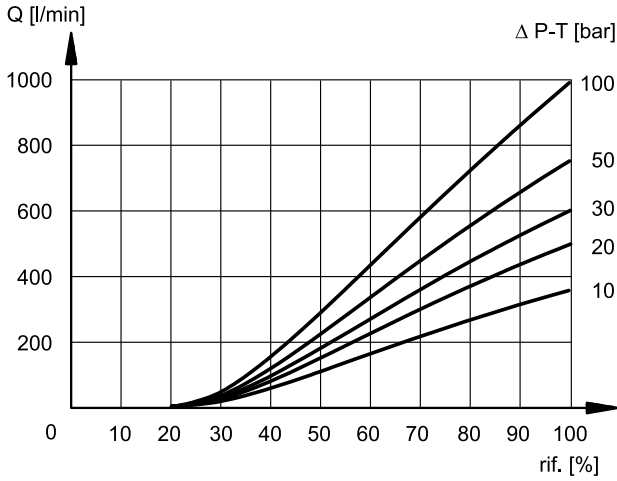

C500 / A500

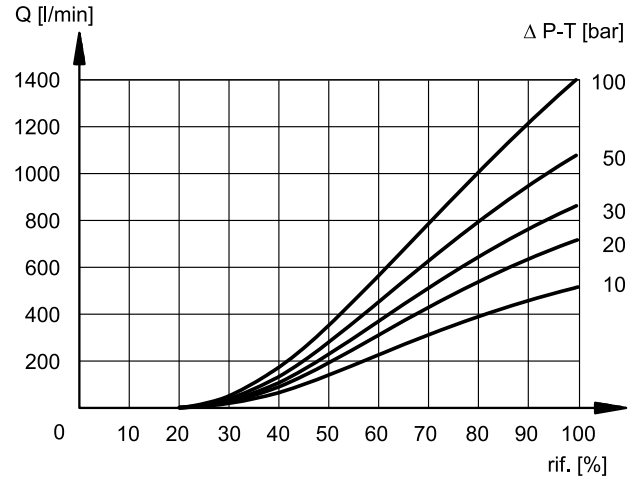

C800 / A800

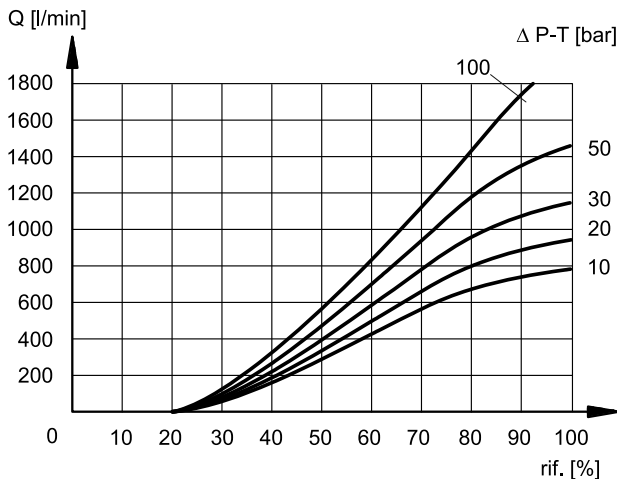

8.5 - Characteristic curves DSPE11G*

C1000 / A1000

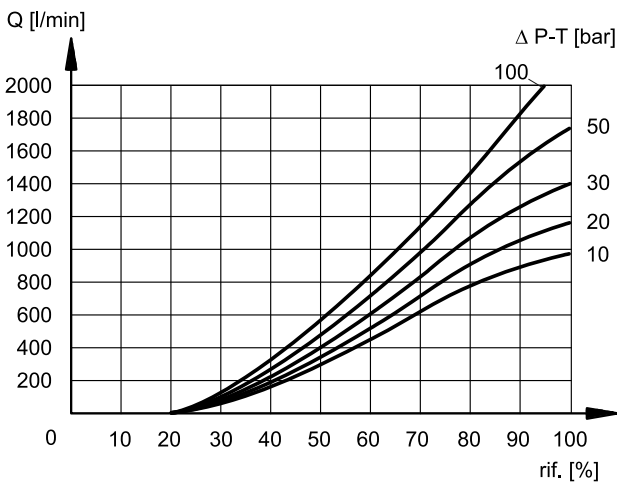

9 - STEP RESPONSE

(obtained with mineral oil with viscosity of 36 cSt at 50°C and static pressure = 100 bar)

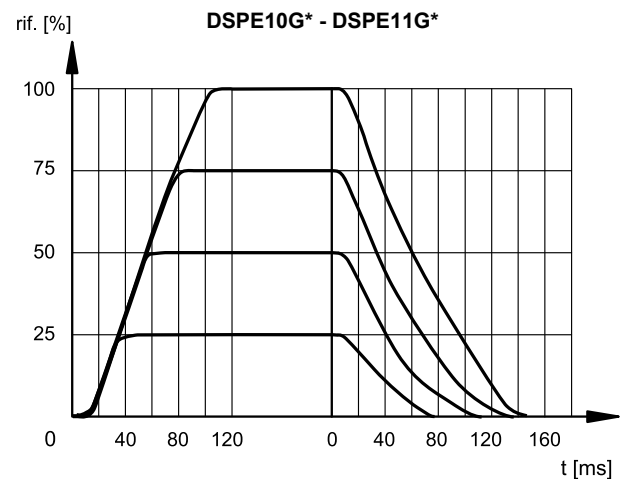
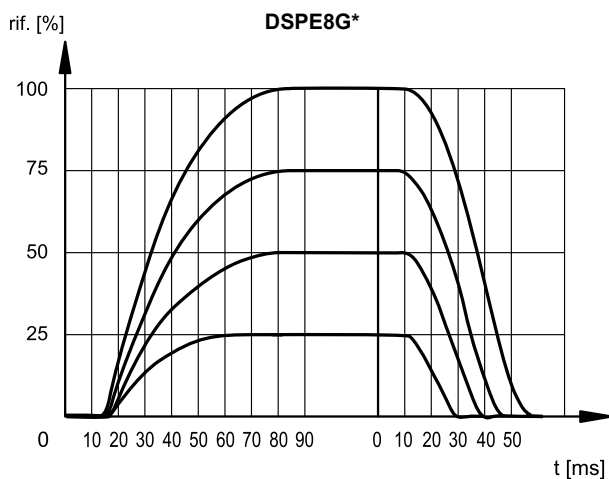
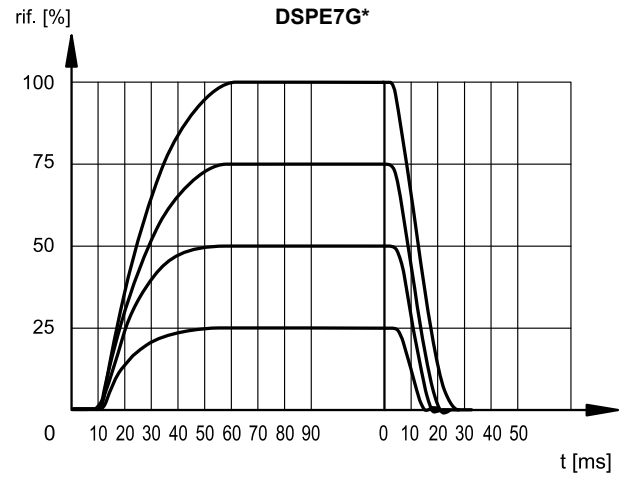
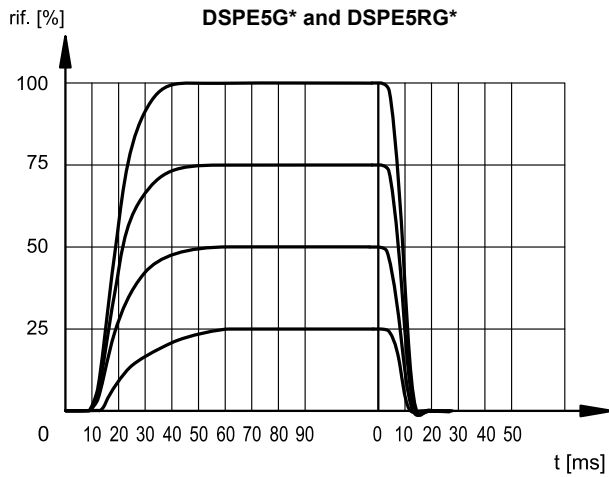

10 - HYDRAULIC CHARACTERISTICS

(with mineral oil with viscosity of 36 cSt at 50°C and static pressure = 100 bar)

FLOWRATES		DSPE5G* DSPE5RG*	DSPE7G*	DSPE8G*	DSPE10G*	DSPE11G*
Max flow rate	l/min	180	450	800	1800	2000
Pilot supply flow requested with operation 0 → 100%	l/min	3.5	4.3	9.2	14.5	14.5
Pilot supply volume requested with operation 0 → 100%	cm ³	1.7	3.2	9.1	21.6	21.6

PRESSURES (bar)	MIN	MAX
Pilot pressure on X port	30	210 (NOTE)
Pressure on T port with internal drain	–	10
Pressure on T port with external drain	–	250

NOTE: if the valve operates with higher pressures, it is necessary to use the version with external pilot and reduced pressure.

Otherwise, the valve with internal pilot and pressure reducing valve with 30 bar fixed adjustment can be ordered (pilot supply type: Z, see section 1).

10.1 - Pilot and drain

DSPE*G valves are available with pilot and drain both internal or external. The version with external drain allows a higher back pressure on the unloading. The version with external pilot with reduced pressure must be used when higher pressures are needed.

The pilot supply Z type consists of an arrangement with internal pilot supply and 30 bar supply pressure for the pilot stage by means of a fixed adjustment pressure reducing valve.

NOTE: The configuration of pilots and drains must be chosen when ordering. Subsequent modifications are allowed only to specialized operators with authorization and in factory.

TYPE OF VALVE	Plug assembly	
	X	Y
IE internal pilot and external drain	NO	YES
II internal pilot and internal drain	NO	NO
EE external pilot and external drain	YES	YES
EI external pilot and internal drain	YES	NO

DSPE5G / DSPE5RG

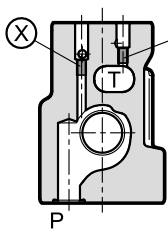

DSPE7G

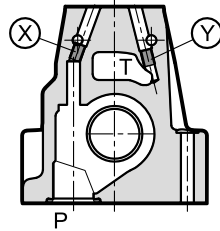

DSPE8G

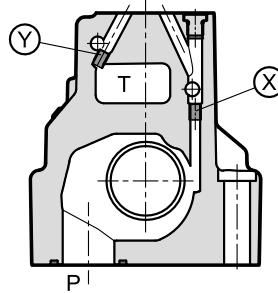

DSPE10/11G

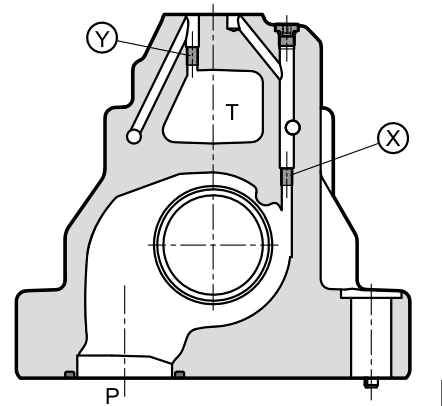

X: plug M5x6 for external pilot
Y: plug M5x6 for external drain

X: plug M6x8 for external pilot
Y: plug M6x8 for external drain

11 - MANUAL OVERRIDE

These valves have solenoids whose pin for manual operation is integrated in the tube. Actuate this override by pushing it with a suitable tool, minding not to damage the sliding surface.

Two other types of manual overrides can fit the DSPE*GL valve:

- **CM** version, manual override boot protected
- **CS** version, with metal ring nut provided with a M4 screw and a blocking locknut.

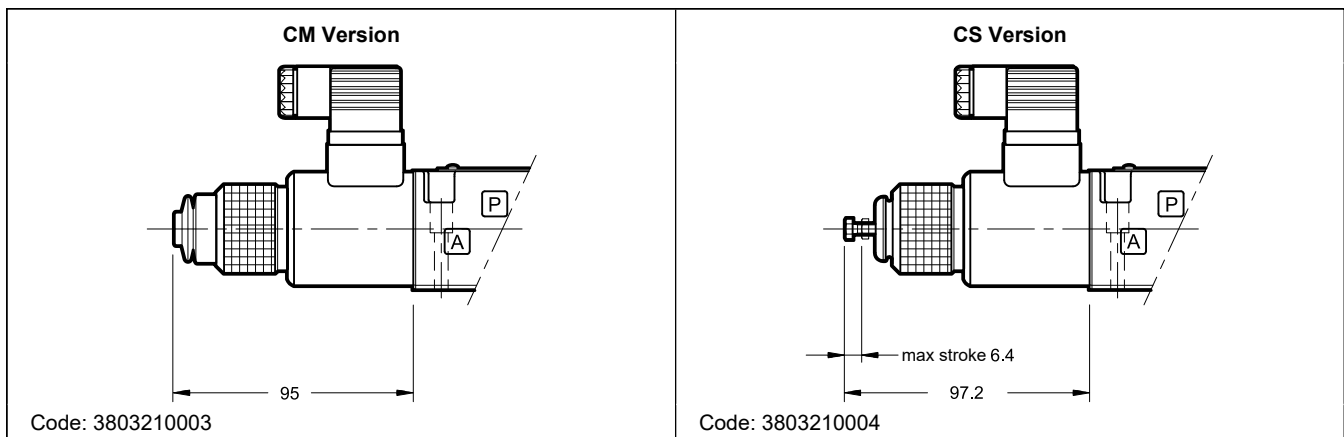

12 - DSPE5G* - OVERALL AND MOUNTING DIMENSIONS

dimensions in mm

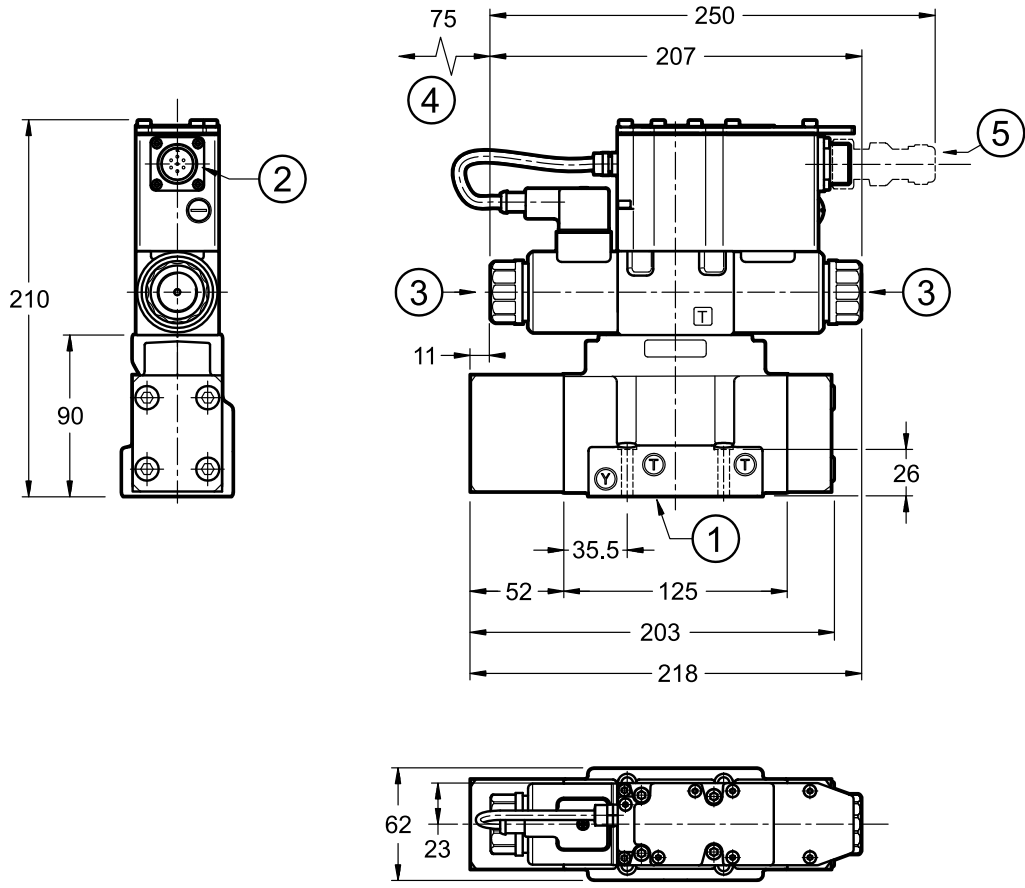

DSPE5GL

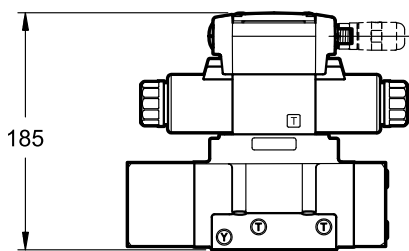

DSPE5GH

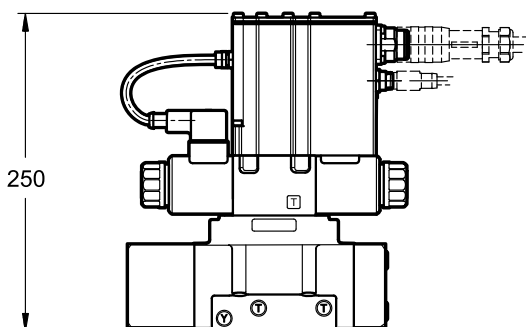

NOTES:

- Mounting surface at point 17.

1	Mounting surface with sealing rings: 5 OR type 2050 (12.42x1.78) - 90 Shore 2 OR type 2037 (9.25x1.78) - 90 Shore
2	Main connection 6 pin + PE
3	Manual override embedded in the solenoid tube
4	Coil removal space
5	Mating connector. To be ordered separately. See catalogue 89 000

Valve fastening: 4 SHC screws M6x35 - ISO 4762
Tightening torque: 8 Nm (A8.8 screws)
Threads of mounting holes: M6x10

13 - DSPE7G* - OVERALL AND MOUNTING DIMENSIONS

dimensions in mm

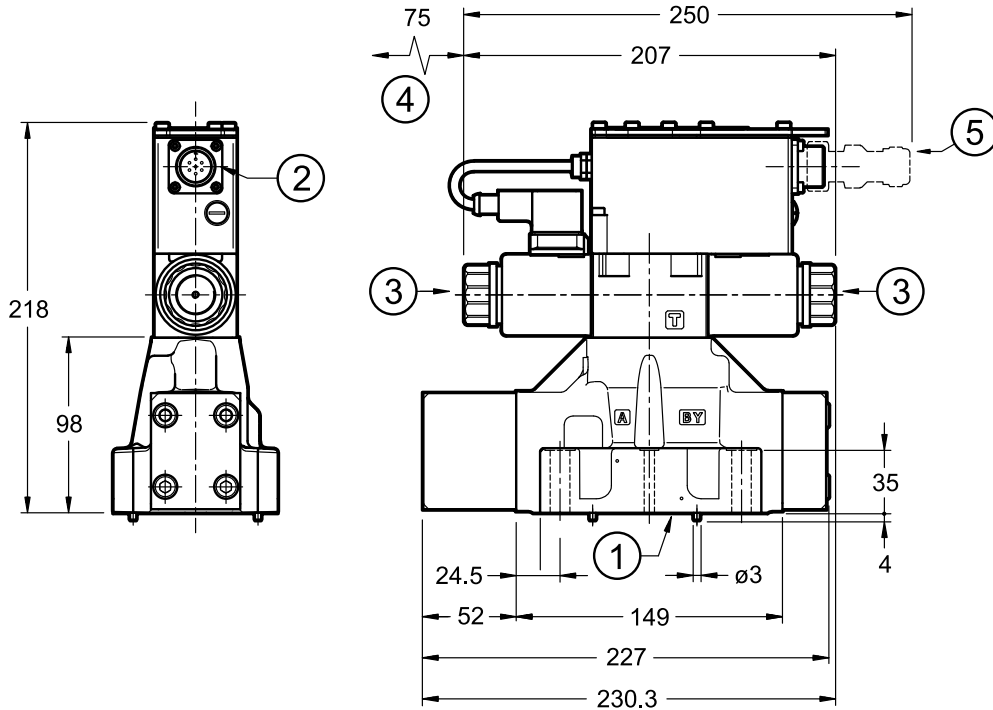

DSPE7GL

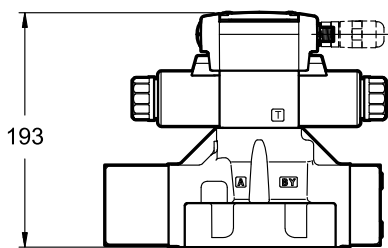

DSPE7GH

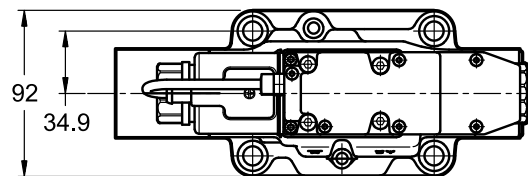

NOTES:

- Mounting surface at point 17.

1	Mounting surface with sealing rings: 4 OR type 130 (22.22x2.62) - 90 Shore 2 OR type 2043 (10.82x1.78) - 90 Shore
2	Main connection 6 pin + PE
3	Manual override embedded in the solenoid tube
4	Coil removal space
5	Mating connector. To be ordered separately. See catalogue 89 000

Valve fastening: 4 SHC screws M10x50 - ISO 4762
2 SHC screws M6x50 - ISO 4762

Tightening torque: M10x50: 40 Nm (A8.8 screws)
M6x50: 8 Nm (A8.8 screws)

Threads of mounting holes: M6x18; M10x18

14 - DSPE8G* - OVERALL AND MOUNTING DIMENSIONS

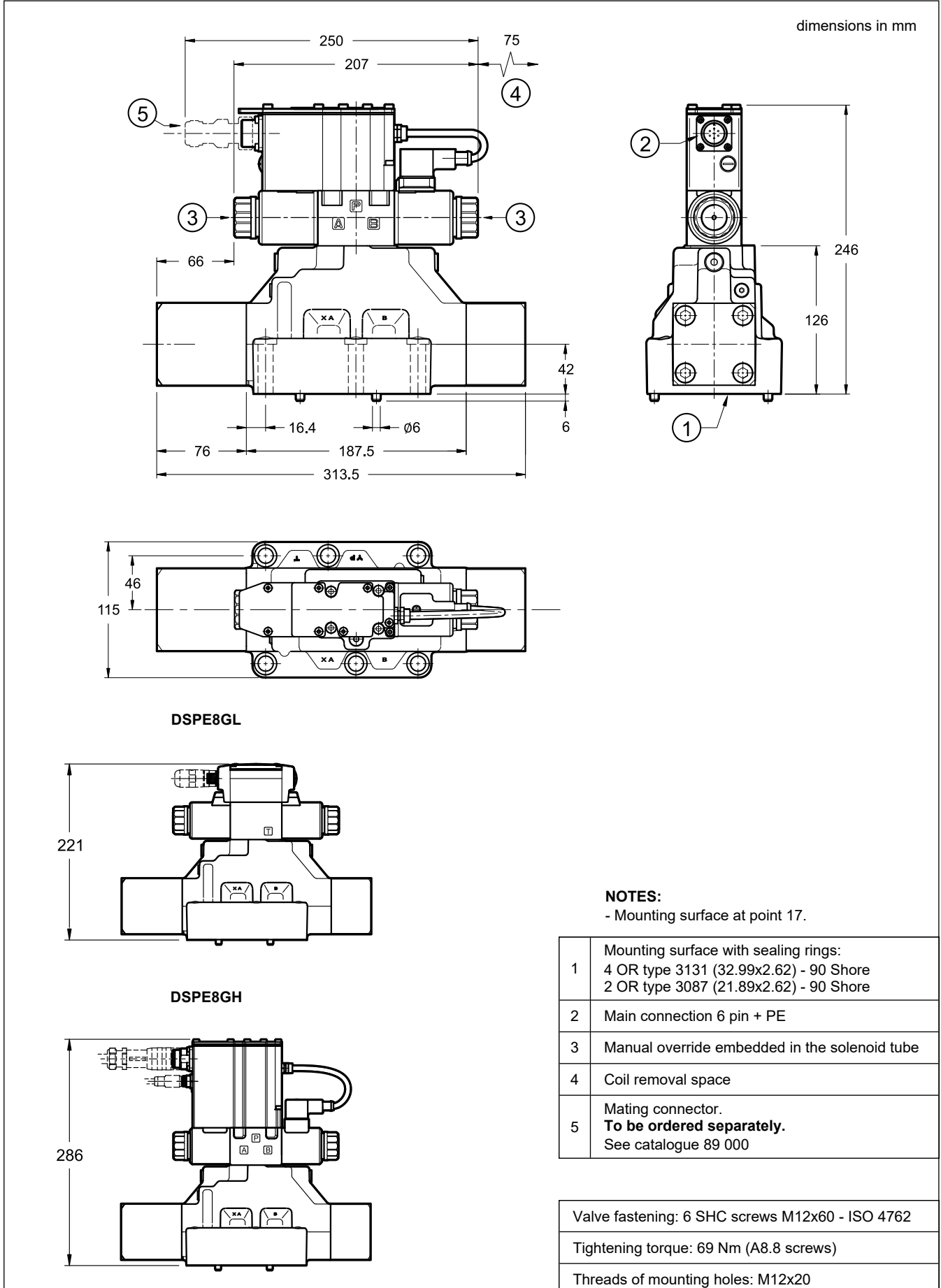

15 - DSPE10G* / DSPE11G* - OVERALL AND MOUNTING DIMENSIONS

dimensions in mm

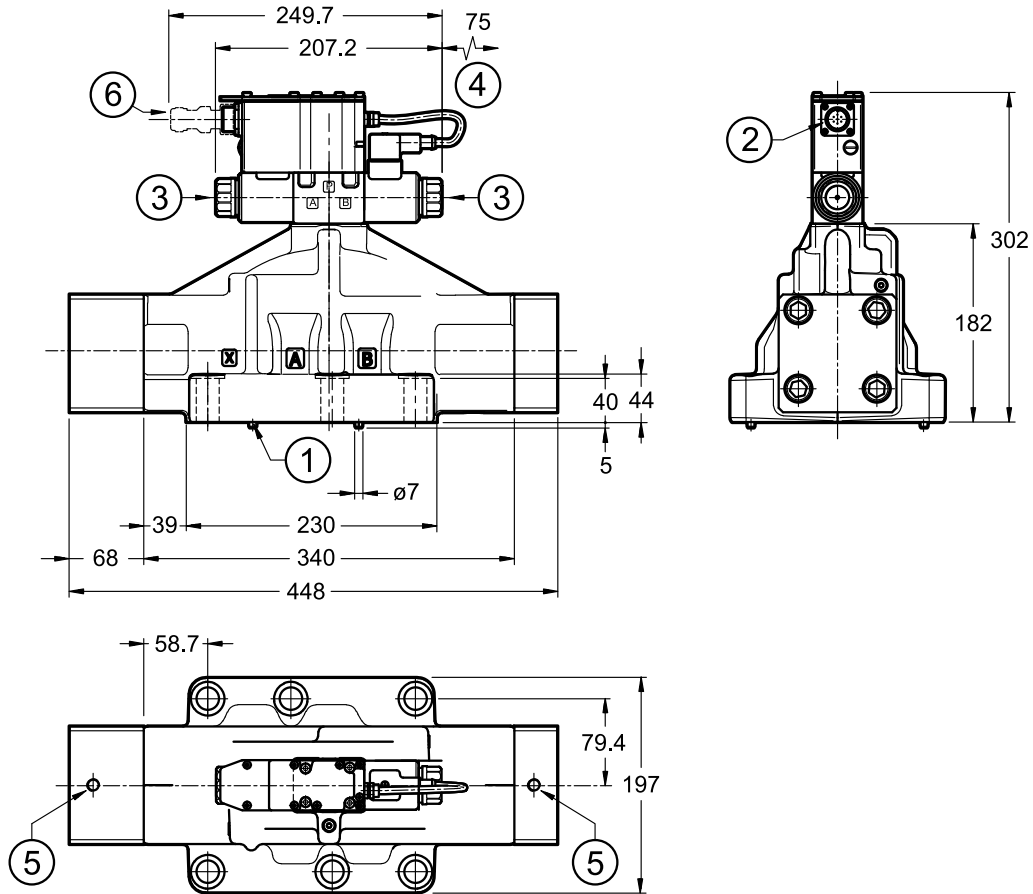

DSPE1*GL

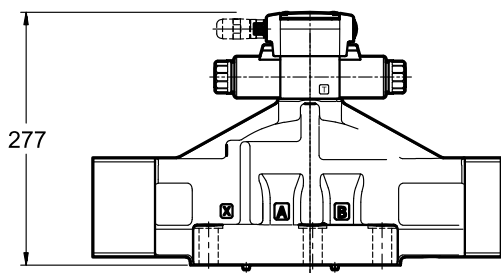

DSPE1*GH

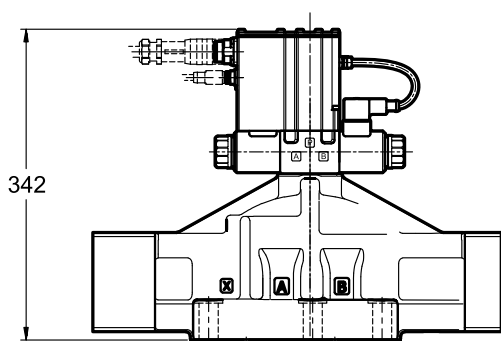

NOTES:

- Mounting surface at point 17.

1	Mounting surface with sealing rings:
	DSPE10G* 4 OR type 4162 (40.86x3.53) - 90 Shore 2 OR type 3081 (20.24x2.62) - 90 Shore DSPE11G* 4 OR type 4212 (53.57x3.53) - 90 Shore 2 OR type 3081 (20.24x2.62) - 90 Shore
2	Main connection 6 pin + PE
3	Manual override embedded in the solenoid tube
4	Coil removal space
5	M12 eyebolt seat for safe lift
6	Mating connector. To be ordered separately. See catalogue 89 000

Valve fastening:
6 SHC screws M20x70 - ISO 4762 (supplied)

Tightening torque: 470 Nm (A10.9 screws)

Threads of mounting holes: M20x40

16 - OVERALL AND MOUNTING DIMENSIONS - PILOT SUPPLY TYPE Z

dimensions in mm

DSPE5G*

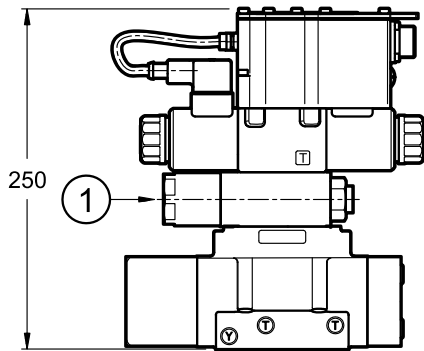

DSPE7G*

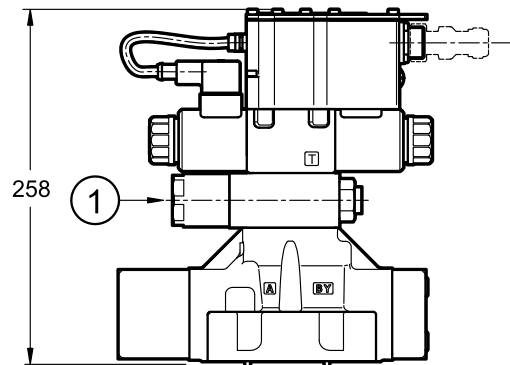

DSPE8G*

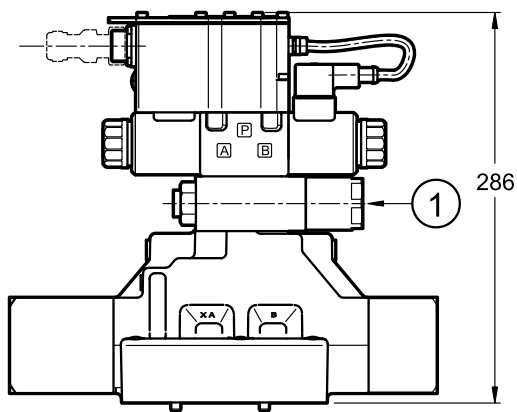

DSPE1*G*

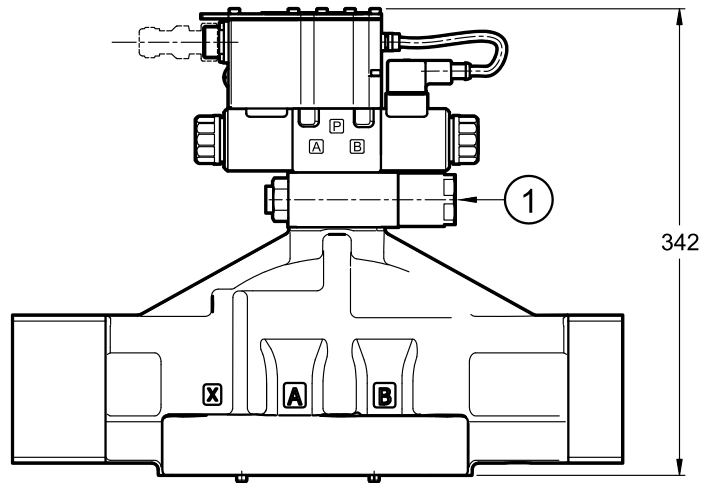

1	30 bar fixed adjustment pressure reducing valve
---	---

17 - MOUNTING SURFACES

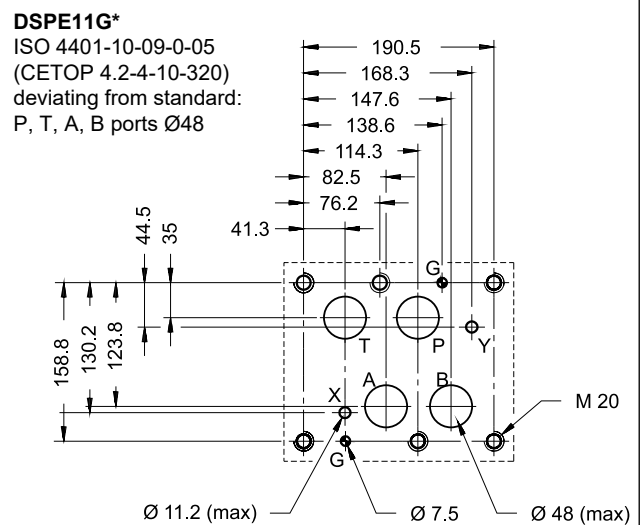
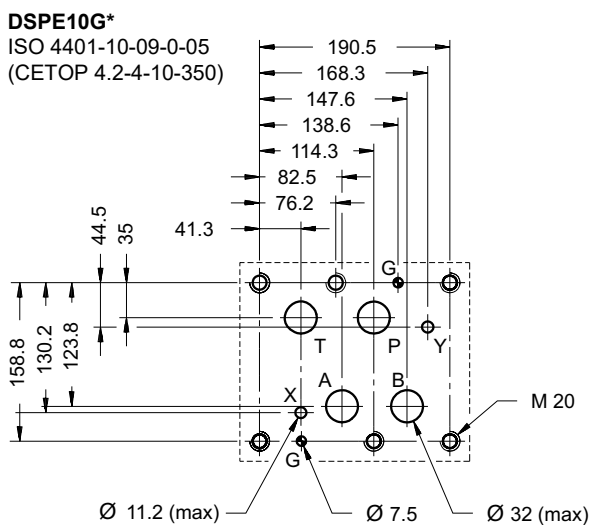
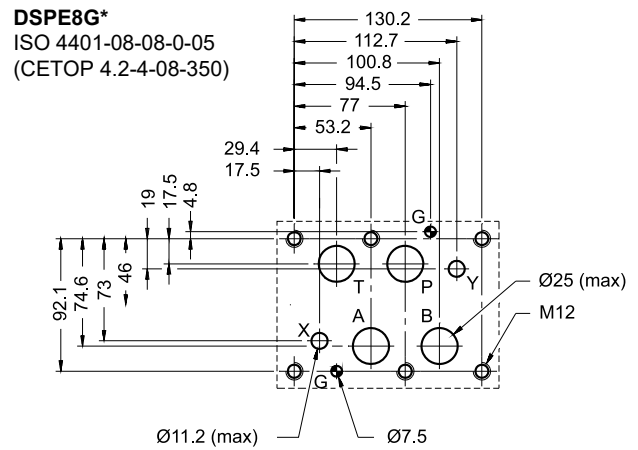
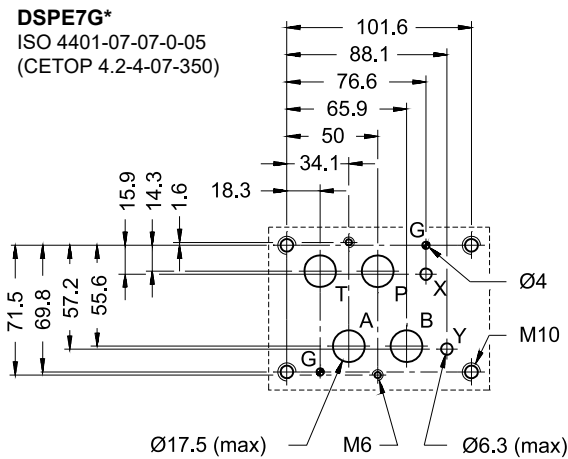
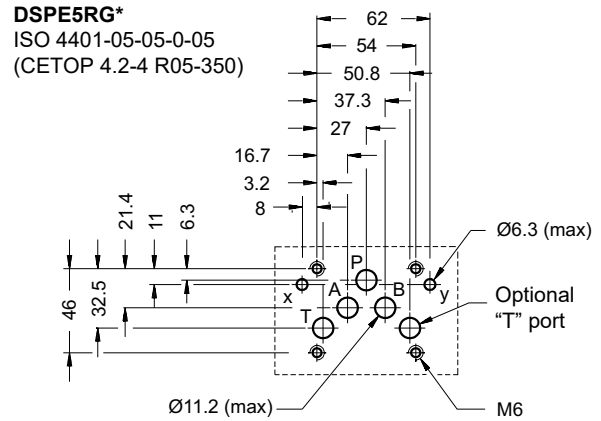
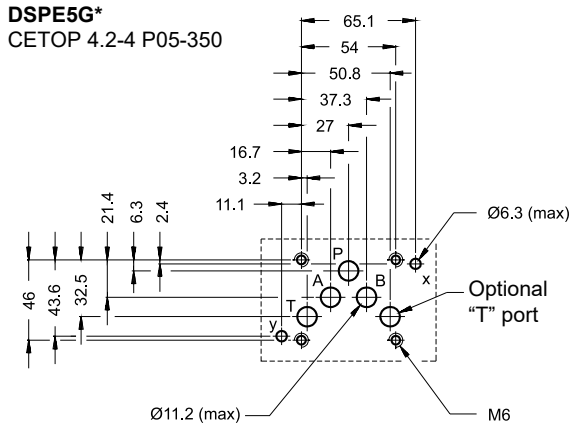

18 - HYDRAULIC FLUIDS

Use mineral oil-based hydraulic fluids HL or HM type, according to ISO 6743-4. For these fluids, use NBR seals (code N). For fluids HFDR type (phosphate esters) use FPM seals (code V). For the use of other kinds of fluid such as HFA, HFB, HFC, please consult our technical department.

Using fluids at temperatures higher than 80 °C causes a faster degradation of the fluid and of the seals characteristics.

The fluid must be preserved in its physical and chemical characteristics.

19 - INSTALLATION

The valves can be installed in any position without impairing correct operation.

Ensure that there is no air in the hydraulic circuit.

Valves are fixed by means of screws or tie rods on a flat surface with planarity and roughness equal to or better than those indicated in the relative symbols. If minimum values are not observed, fluid can easily leak between the valve and support surface.

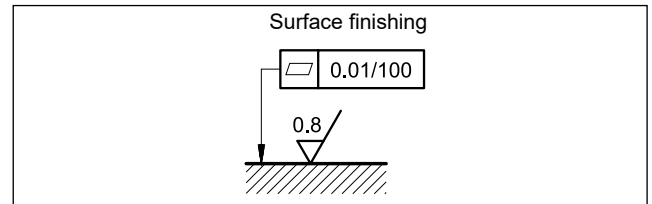

20 - ACCESSORIES

(to be ordered separately)

20.1 - Mating connectors

Mating connectors must be ordered separately. See catalogue 89 000.



For K11 and K16 versions we recommend the choice of a metal connector to avoid electromagnetic disturbances and to comply with EMC regulations on electromagnetic compatibility. If you opt for a plastic connector, make sure that it guarantees and maintains the IP and EMC protection characteristics of the valve.

20.2 - Mating connectors and caps for fieldbus communication

Duplomatic offers spare parts to be wired and also ready-to-use cord sets. Please refer to cat. 89 000.

20.3 - Connection cable

The optimal wiring provides for 7 isolated conductors, with separate screen for the signal wires (command, monitor) and an overall screen.

Cross section for power supply:

- up to 20 m cable length : 1,0 mm²
- up to 40 m cable length : 1,5 mm² (IO-Link excluded)

Cross section for signals (command, monitor):

- 0,50 mm²

20.4 - Kit for start-up LINPC-USB

Device for service start-up and diagnostic. See catalogue 89 850.

21 - SUBPLATES

(see catalogue 51 000)

No subplates are available for DSPE5RG*, DSPE10G* and DSPE11G*.

	DSPE5G*	DSPE7G*	DSPE8G*
Type with rear ports	PME4-AI5G	PME07-AI6G	-
Type with side ports	PME4-AL5G	PME07-AL6G	PME5-AL8G
P, T, A, B ports dimensions	3/4" BSP	1" BSP	1 1/2" BSP
X, Y ports dimensions	1/4" BSP	1/4" BSP	1/4" BSP



DSPE*G*

DUPLOMATIC
MOTION SOLUTIONS
*a member of **DAIKIN** group*

DUPLOMATIC MS Spa

via Mario Re Depaolini, 24 | 20015 Parabiago (MI) | Italy

T +39 0331 895111 | E vendite.ita@duplomatic.com | sales.exp@duplomatic.com

duplomaticmotionsolutions.com