

DSE3J*

PROPORTIONAL DIRECTIONAL VALVE WITH FEEDBACK AND INTEGRATED ELECTRONICS

SUBPLATE MOUNTING ISO 4401-03

p max 350 bar
Q max 80 l/min

MOUNTING INTERFACE

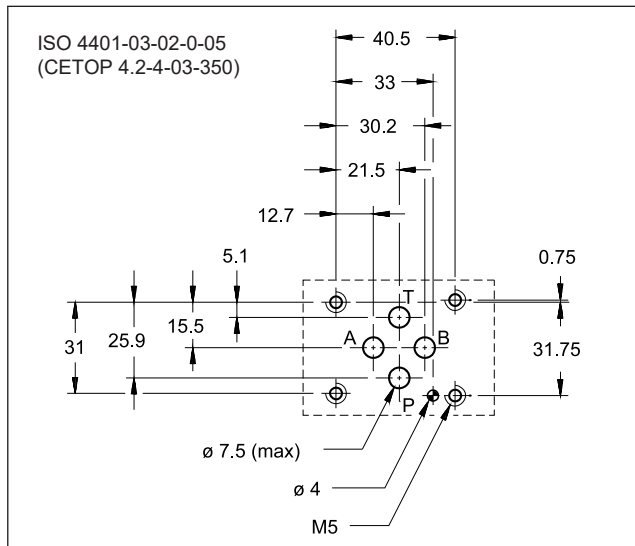

OPERATING PRINCIPLE

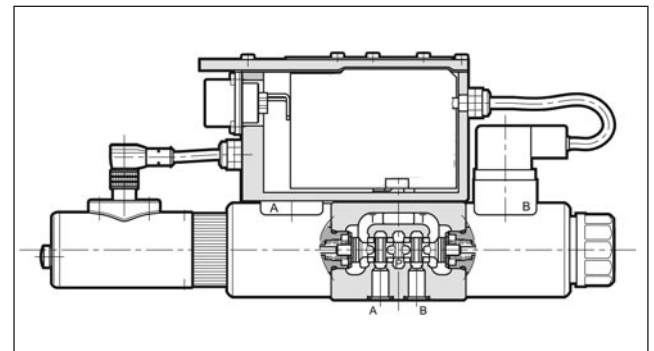

- The DSE3J* are proportional directional valves, direct operated, with closed loop position control. The mounting interface is in compliance with ISO 4401 standards.
- The valve opening and hence flow rate can be modulated continuously in proportion to the reference signal. Transducer and digital card allow a fine control of the spool position, reducing both hysteresis and response times and optimizing the valve performance.
- The valves are available with different types of electronics, with analogue or fieldbus interfaces.
- The fail safe function is available for spools type Z.
- Valves are easy to install. The driver manages digital settings directly.

PERFORMANCES

(Mineral oil with viscosity of 36 cSt at 50°C and p = 140 bar)

Max operating pressure: P - A - B ports T port	bar	350 210
Nominal flow with Δp 10 bar P-T	l/min	1 - 4 - 12 - 18 - 30
Response times	see point 7	
Hysteresis	% of Q_{max}	< 0.2%
Repeatability	% of Q_{max}	< 0.2%
Threshold		< 0.1%
Valve reproducibility		$\leq 5\%$
Electrical characteristics	see point 3	
Ambient temperature range	°C	-20 / +60
Fluid temperature range	°C	-20 / +80
Fluid viscosity range	cSt	10 ÷ 400
Fluid contamination degree	according to ISO 4406:1999 class 18/16/13	
Recommended viscosity	cSt	25
Mass: single solenoid valve double solenoid valve	kg	2.2 2.7

HYDRAULIC SYMBOLS (typical)

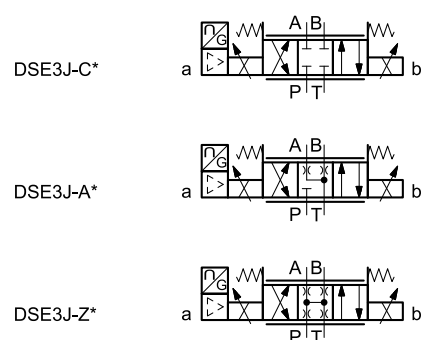

1 - IDENTIFICATION CODE

1.1 - Standard electronics

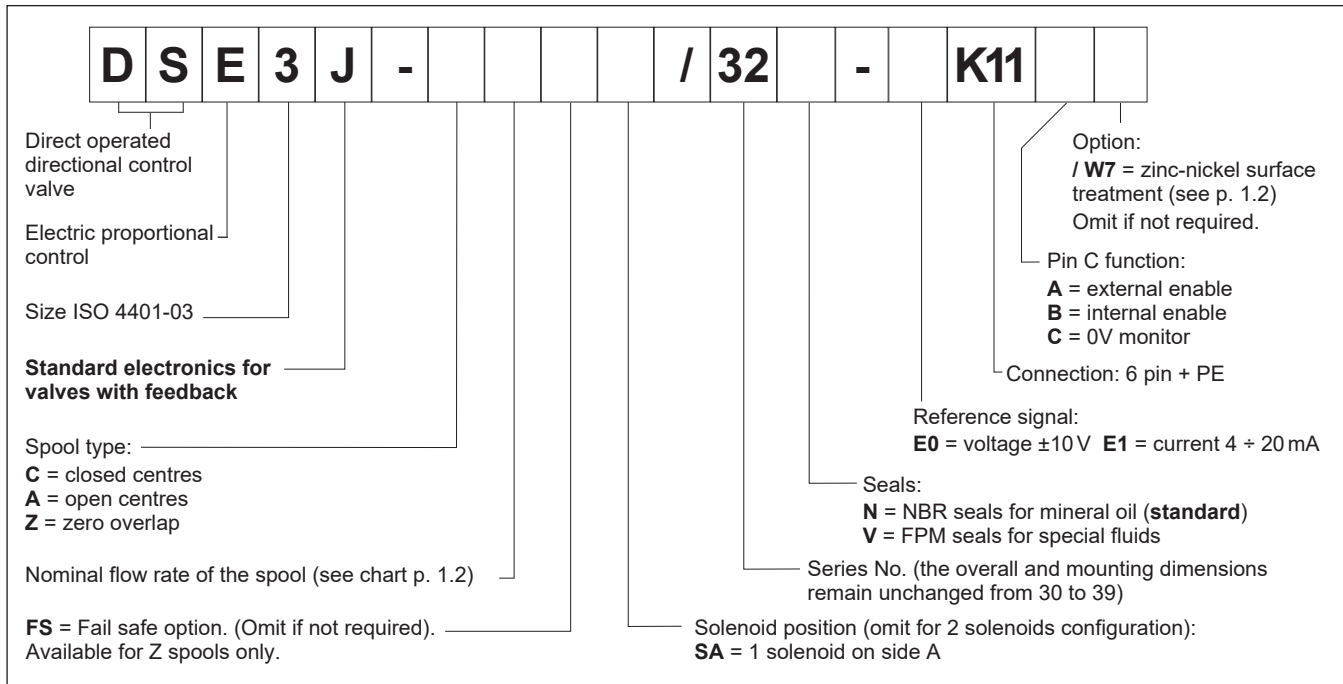

1.2 - Surface treatments

The standard valve is supplied with surface treatment of phosphating black. The zinc-nickel finishing on the valve body makes the valve suitable to ensure a salt spray resistance up to 240 hours. (test operated according to UNI EN ISO 9227 standards and test evaluation operated according to UNI EN ISO 10289 standards).

1.3 - Configurations

Valve configuration depends on the combination of the following elements: number of proportional solenoids, spool type, rated flow.

Configuration 2 solenoids (**NOTE**):
3 positions with spring centering

Configuration 1 solenoid on side A "**SA**":
2 positions (central + external) with spring centering (for DSE3J and DSE3JH only)

Configuration 1 solenoid on side B "**SB**":
2 positions (central + external) with spring centering (for DSE3JL only)

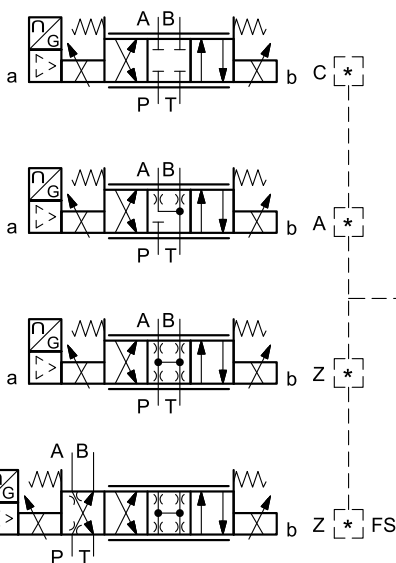

Controlled flow with $\Delta p 10$ bar P-T	
01	1 l/min
04	4 l/min
12	12 l/min
18	18 l/min (spool type C only)
30	30 l/min
30/15	30 (P-A) / 15 (P-B) l/min

NOTE: On DSE3JL the feedback is placed at side b

1.4 - Compact electronics

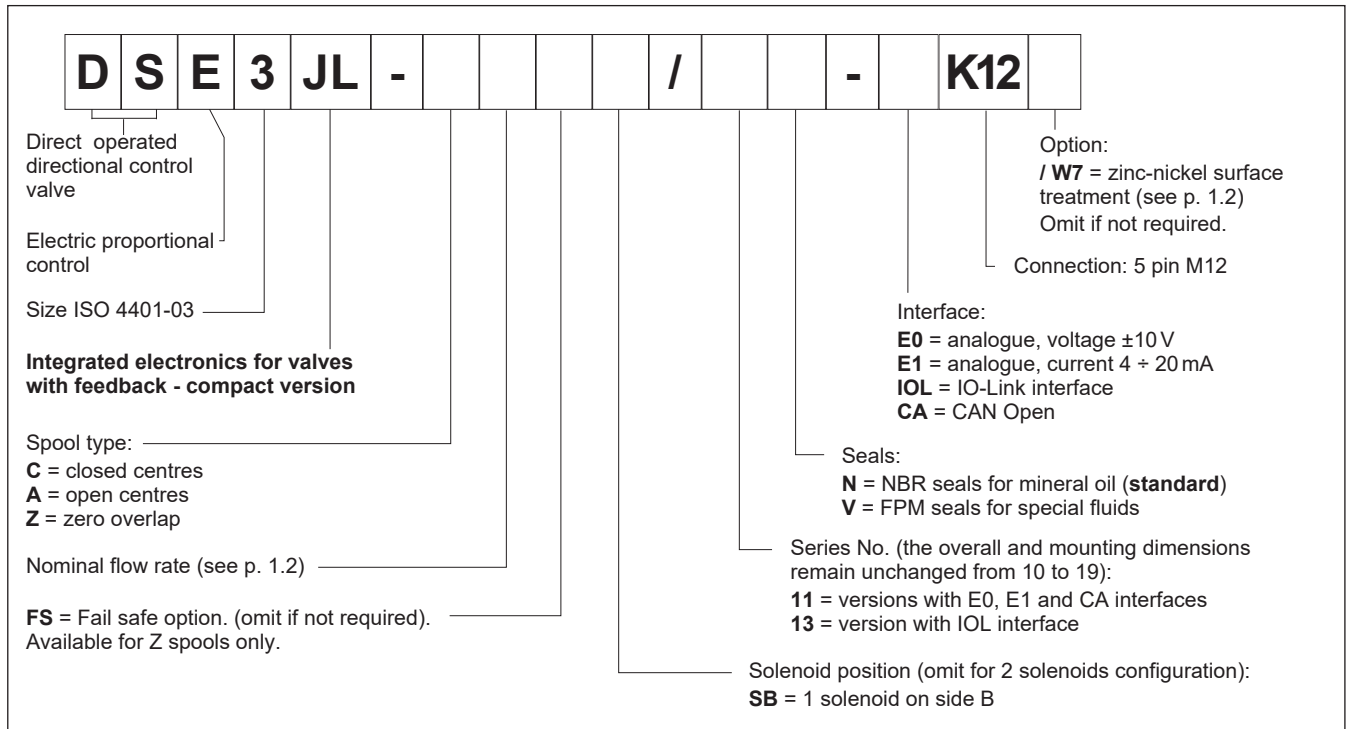

1.5 - Electronics with fieldbus communication

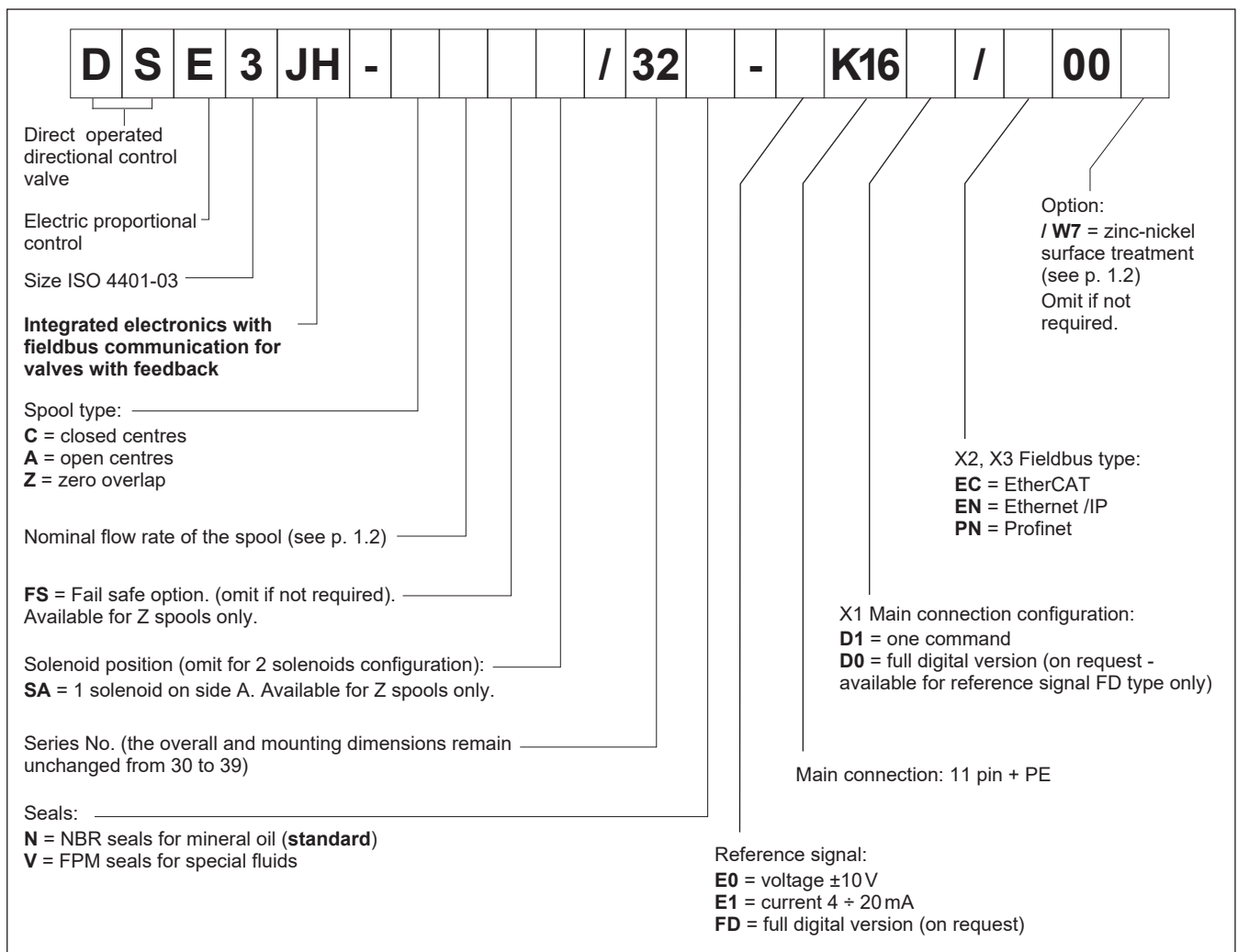

2 - ELECTRONICS COMMON DATA

Duty cycle		100% (continuous operation)
Protection class according to EN 60529		IP65/IP67 (NOTE)
Supply voltage	V DC	24 (from 19 to 30 VDC), ripple max 3 Vpp
Power consumption	VA	25
Maximum solenoid current	A	1.88
Fuse protection, external	A	3
Managed breakdowns		Overload and electronics overheating, LVDT sensor error, cable breakdown, supply voltage failure
Electromagnetic compatibility (EMC) emissions EN 61000-6-4, immunity EN 61000-6-2		According to 2014/30/EU standards

NOTE: The IP degree is guaranteed only with mating connector of equivalent IP degree, installed and tightened correctly. Moreover, on the JH versions it is necessary to protect any unused connections with caps.

3 - DSE3J - STANDARD ELECTRONICS

3.1 - Electrical characteristics

Command signal:	voltage (E0) current (E1)	V DC mA	± 10 (impedance $R_i > 11 \text{ kohm}$) $4 \div 20$ (impedance $R_i = 58 \text{ ohm}$)
Monitor signal:	voltage (E0) current (E1)	V DC mA	± 10 (impedance $R_o > 1 \text{ kohm}$) $4 \div 20$ (impedance $R_o = 500 \text{ ohm}$)
Communication for diagnostic			LIN-bus Interface (by means of the optional kit)
Connection			6 pin + PE (MIL-C-5015-G - DIN EN 175201-804)

3.2 - On-board electronics diagrams

VERSION A - External Enable

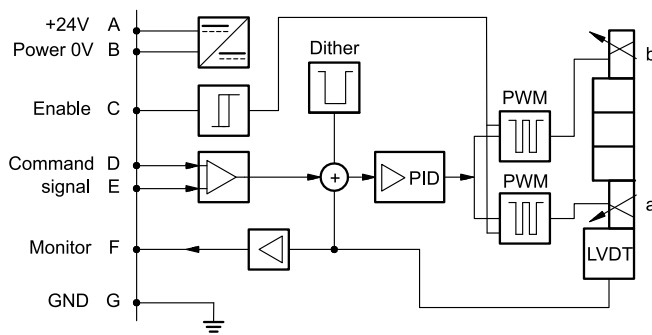

VERSION B - Internal Enable

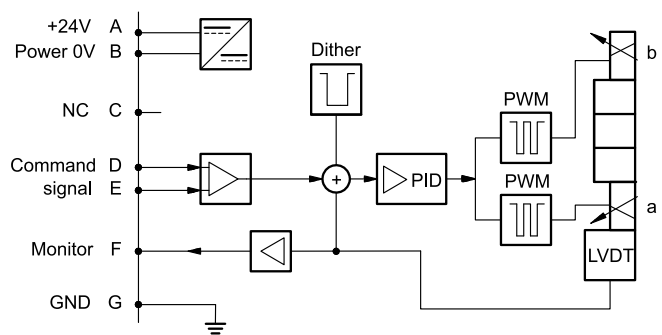

VERSION C - 0V Monitor

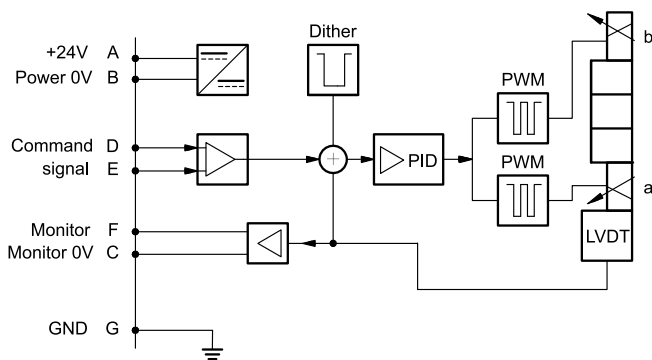

3.3 - Versions with voltage command (E0)

The reference signal is between -10V and +10V on double solenoid valve, and 0 + 10V on single solenoid valve SA. The monitor feature of versions B and C becomes available with a delay of 0,5 sec from the power-on of the card.

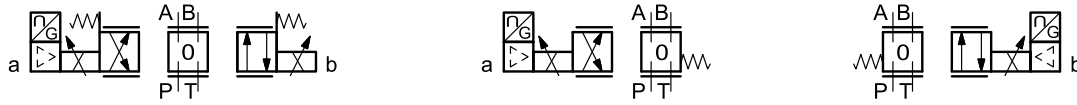

COMMAND	-10V	0V	+10V	+10V	0V	0V	+10V
MONITOR	-10V	0V	+10V	+10V	0V	0V	+10V

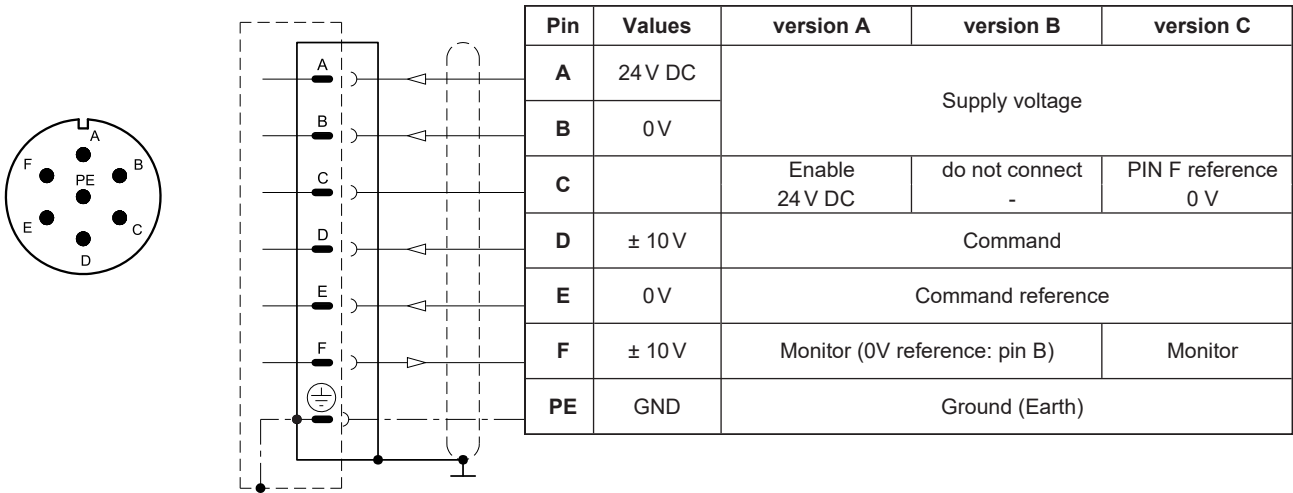

3.4 - Versions with current command (E1)

The reference signal is supplied in current 4 + 20 mA. If the current for command is lower, the card shows a breakdown cable error. To reset the error is sufficient to restore the signal.

The monitor feature of versions B and C becomes available with a delay of 0,5 sec from the power-on of the card.

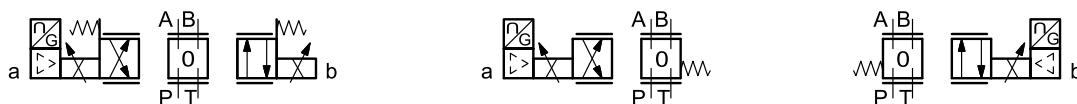

COMMAND	4 mA	12 mA	20 mA	20 mA	4 mA	4 mA	20 mA
MONITOR	4 mA	12 mA	20 mA	20 mA	4 mA	4 mA	20 mA

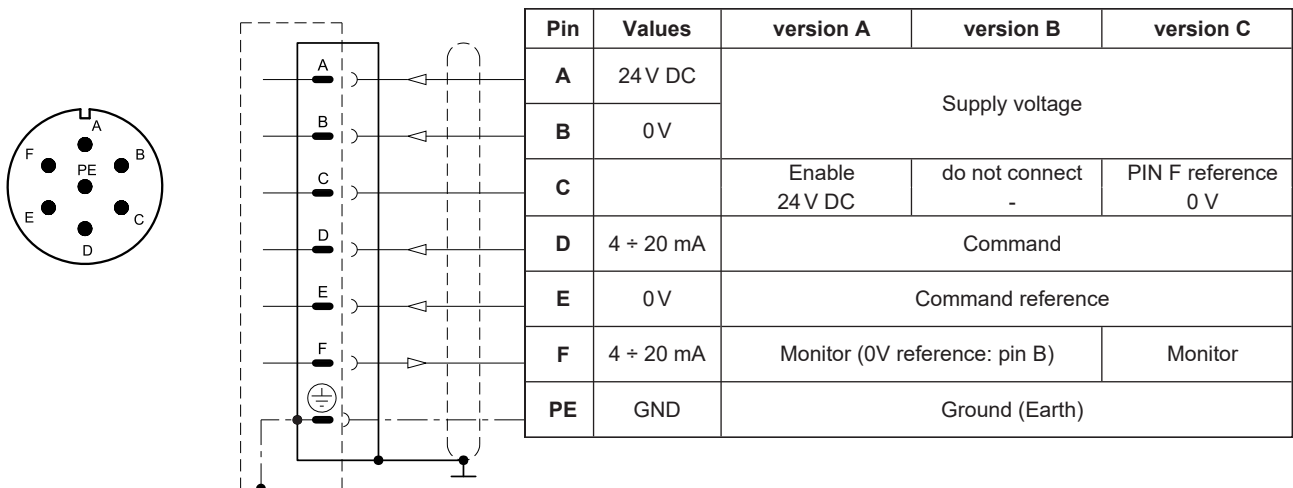

4 - DSE3JL - COMPACT ELECTRONICS

In IO-Link networks, the length of the connecting cables is limited to 20 metres. In CA versions, pin 3 and pin 5 are galvanic isolated up to 100 V to avoid earth loops.

4.1 - Electrical characteristics

Command signal:	voltage (E0) current (E1)	V DC mA	± 10 (impedance $R_i > 11 \text{ kohm}$) $4 \div 20$ (impedance $R_i = 58 \text{ ohm}$)
Monitor signal :	voltage (E0) current (E1)	V DC mA	$0 \div 5$ (impedance $R_o > 1 \text{ kohm}$) $4 \div 20$ (impedance $R_o = 500 \text{ ohm}$)
IO-Link communication (IOL): Data rate		kBaud	IO-Link Port Class B 38.4
Can Open communication (CA): Data rate		kbit	$10 \div 1000$
Data register (IOL and CA versions only)			card voltage supply, solenoid faults (shortcircuit, bad configuration), box temperature.
Connection			5-pin M12 code A (IEC 61076-2-101)

4.2 - Pin tables

'E0' connection

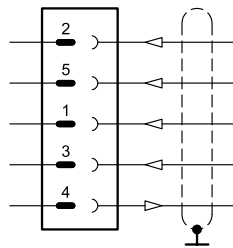

Pin	Values	Function
2	24 V DC	Supply voltage (solenoid and logic)
5	0 V	
1	$\pm 10 \text{ V}$	Command
3	0 V	Command reference
4	$0 \div 5 \text{ V}$	Monitor (0V reference: pin 5)

'E1' connection

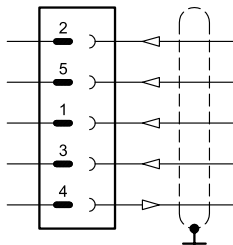

Pin	Values	Function
2	24 V DC	Supply voltage (solenoid and logic)
5	0 V	
1	$4 \div 20 \text{ mA}$	Command
3	0 V	Command reference
4	$4 \div 20 \text{ mA}$	Monitor (0V reference: pin 5)

'IOL' connection

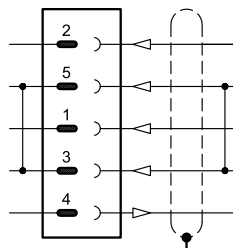

Pin	Values	Function
2	2L+ 24 V DC	Solenoid supply voltage
5	2L- 0 V (GND)	
1	1L+ +24 V DC	Logic and IO-Link supply voltage
3	1L- 0 V (GND)	
4	C/Q	IO-Link Communication

NOTE: Pin 3 and pin 5 are linked with each other in the valve electronics. The reference potentials 1L- and 2L- of the two supply voltages must also be linked with each other on the customer side.

'CA' connection

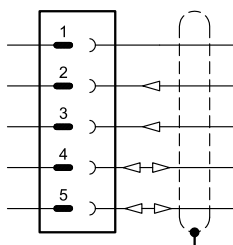

Pin	Values	Function
1	CAN_SH	Shield
2	24 V DC	Supply voltage
3	0 V (GND)	
4	CAN_H	Bus line (high)
5	CAN_L	Bus line (low)

5 - DSE3JH - FIELDBUS ELECTRONICS

The 11+ PE pin connection allows separate supply voltage for electronics and solenoids.

Command - valve position schemes as for the standard electronics. Please refer to pictures in p. 3.3 and 3.4.

5.1 - Electrical characteristics

Command signal:	voltage (E0) current (E1) digital (FD)	V DC mA	± 10 (impedance $R_i > 11 \text{ kohm}$) $4 \div 20$ (impedance $R_i = 58 \text{ ohm}$) via fieldbus
Monitor signal:	voltage (E0) current (E1)	V DC mA	± 10 (impedance $R_o > 1 \text{ kohm}$) $4 \div 20$ (impedance $R_o = 500 \text{ ohm}$)
Communication / diagnostic			via Bus register
Communication interface standards			IEC 61158
Communication physical layer			fast ethernet, insulated 100 Base TX
Power connection			11 pin + PE (DIN 43651)

5.2 - X1 Main connection pin table

D1: one command

Pin	Values	Function
1	24 V DC	Main supply voltage
2	0 V	
3	24 V DC	Enable
4	$\pm 10 \text{ V}$ (E0) $4 \div 20$ (E1)	Command
5	0 V	Command reference signal
6	$\pm 10 \text{ V}$ (E0) $4 \div 20$ (E1)	Monitor (0V reference pin 10)
7	NC	do not connect
8	NC	do not connect
9	24 V DC	Logic and control supply
10	0 V	
11	24 V DC	Fault (0V DC) or normal working (24V DC) (0V reference pin 2)
12	GND	Ground (Earth)

D0: full digital

Pin	Values	Function
1	24 V DC	Main supply voltage
2	0 V	
3	24 V DC	Enable
4	NC	do not connect
5	NC	do not connect
6	NC	do not connect
7	NC	do not connect
8	NC	do not connect
9	24 V DC	Logic and control supply
10	0 V	
11	24 V DC	Fault (0V DC) or normal working (24V DC) (0V ref. pin 2)
12	GND	Ground (Earth)

5.3 - FIELDBUS connections

Please wire following guidelines provided by the related standards communication protocol. Any connections present and not used must be protected with special caps so as not to nullify the protection against atmospheric agents.

X2 (IN) connection: M12 D 4 pin female



Pin	Values	Function
1	TX+	Transmitter
2	RX+	Receiver
3	TX-	Transmitter
4	RX-	Receiver
HOUSING	shield	

X3 (OUT) connection: M12 D 4 pin female



Pin	Values	Function
1	TX+	Transmitter
2	RX+	Receiver
3	TX-	Transmitter
4	RX-	Receiver
HOUSING	shield	

NOTE: Shield connection on connector housing is recommended.

6 - CHARACTERISTIC CURVES

(obtained with mineral oil with viscosity of 36 cSt at 50°C and with digital integrated electronics)

Typical flow rate curves related to the reference signal and measured for the available spools. The Δp values are measured between P and T valve ports.

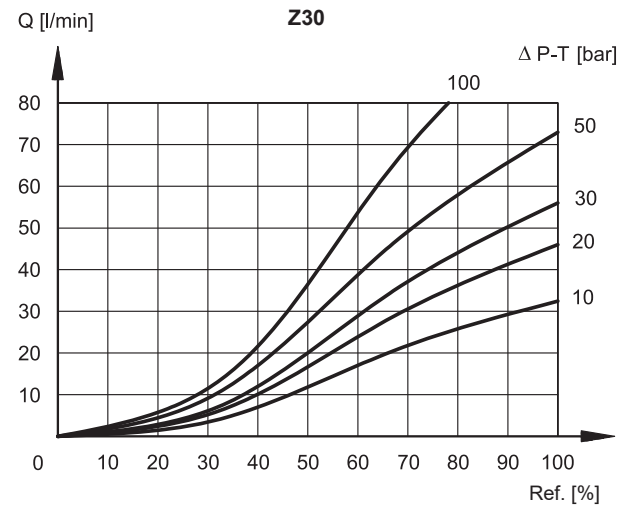
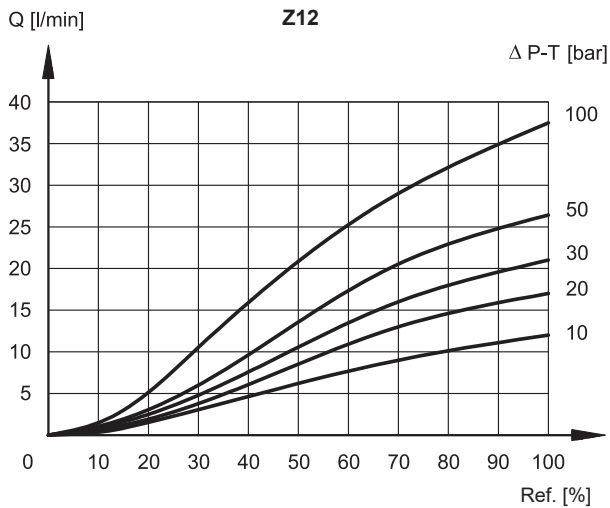
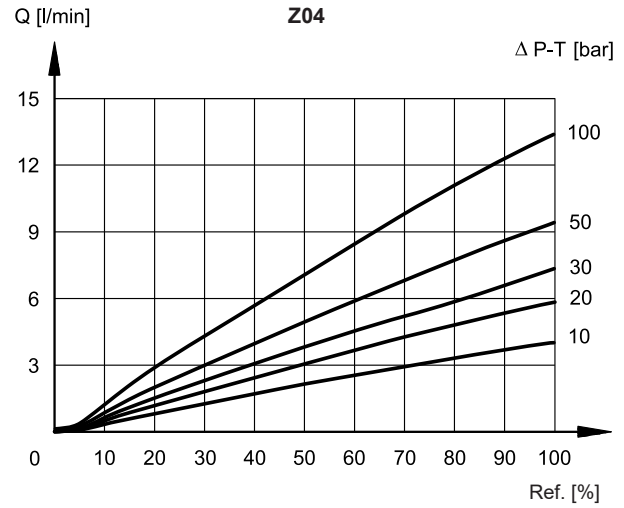
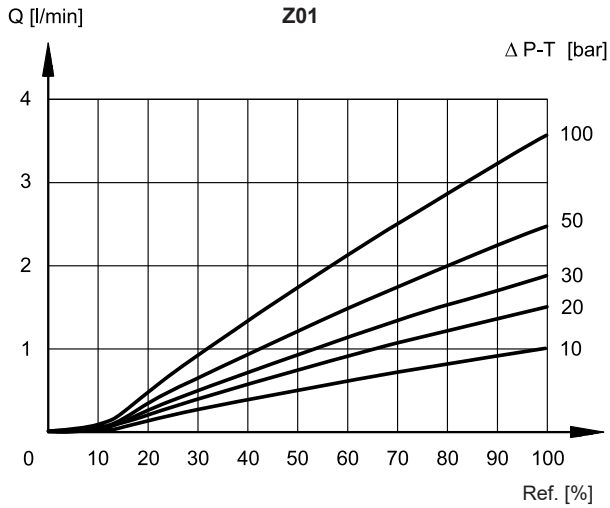
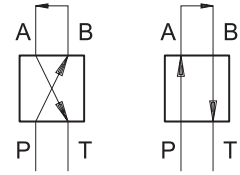

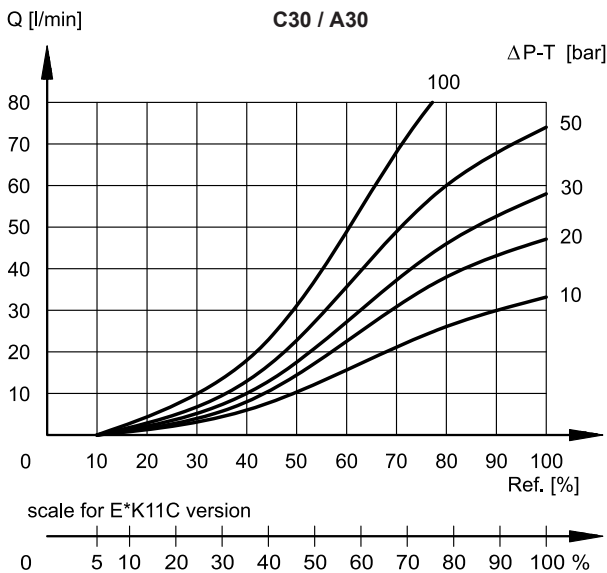
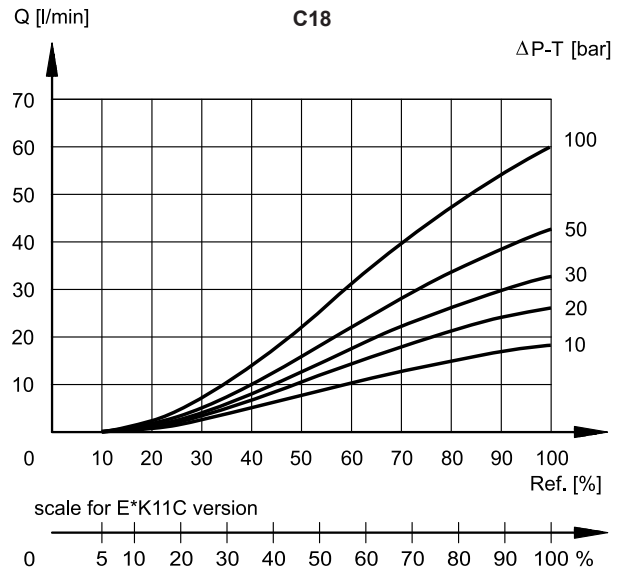
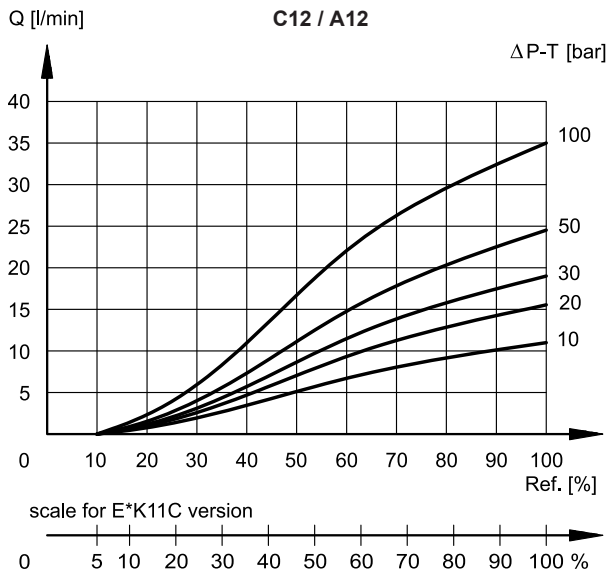
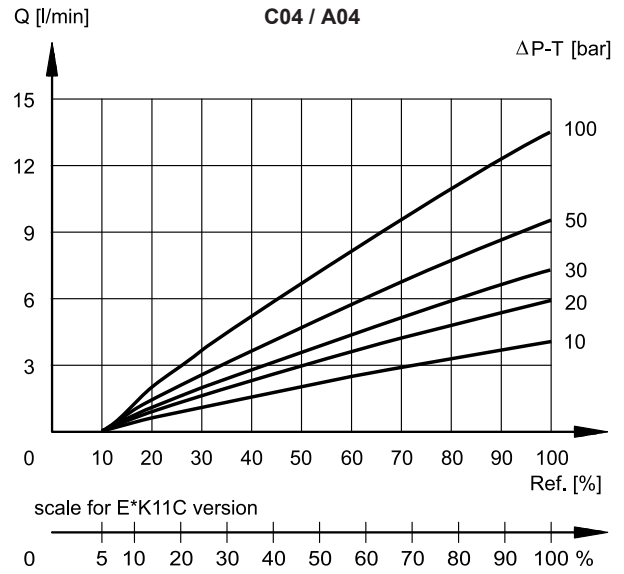
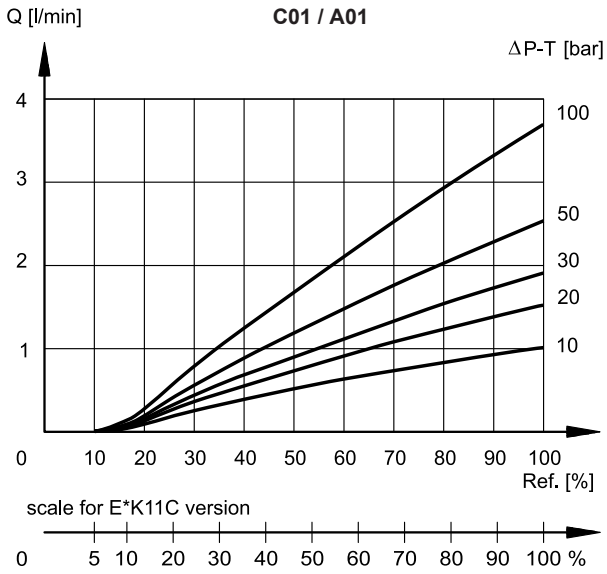

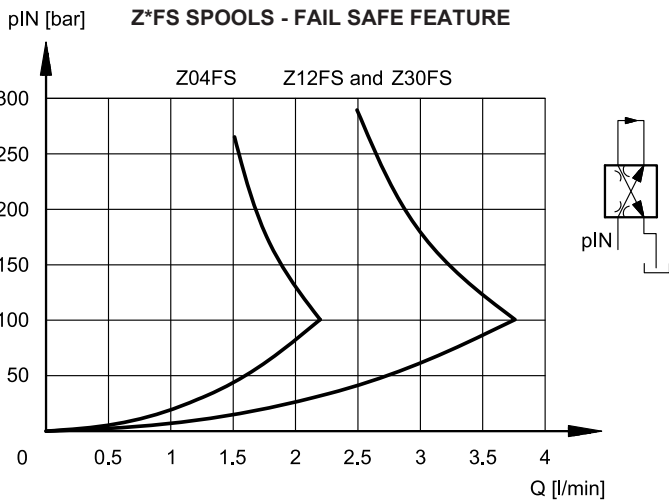

Flow P→B / A→T with valve in fail safe position, depending on the inlet pressure.

When a power failure (enabling OFF) occurs, the valve moves in 'fail safe' position, maintaining a minimum flow that allows the actuator to return slowly to a safe position.

During the black-out the centering springs retain the spool in fail safe-position.

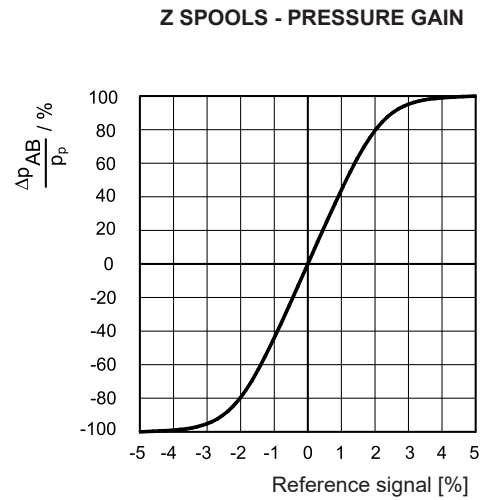

The diagram shows the valve pressure gain, expressed as % of the ratio between the port pressure variation in A or B (Δp_{AB}) and the P system pressure, according to the reference signal.

In practice, the pressure gain states the valve reaction towards external disturbances aimed at changing the actuator position.

7 - RESPONSE TIMES

(obtained with mineral oil with viscosity of 36 cSt at 50°C and 140 bar Δp P→T)

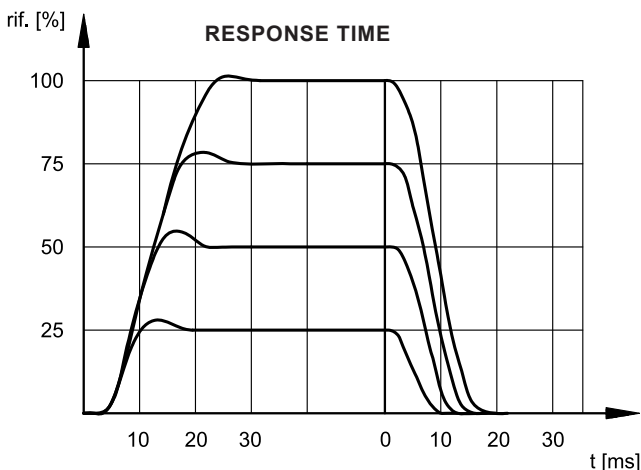
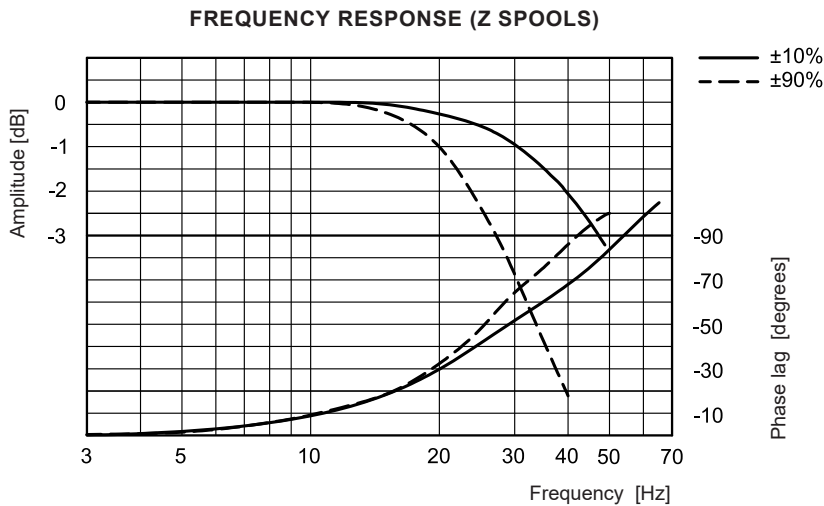

8 - DSE3J - OVERALL AND MOUNTING DIMENSIONS

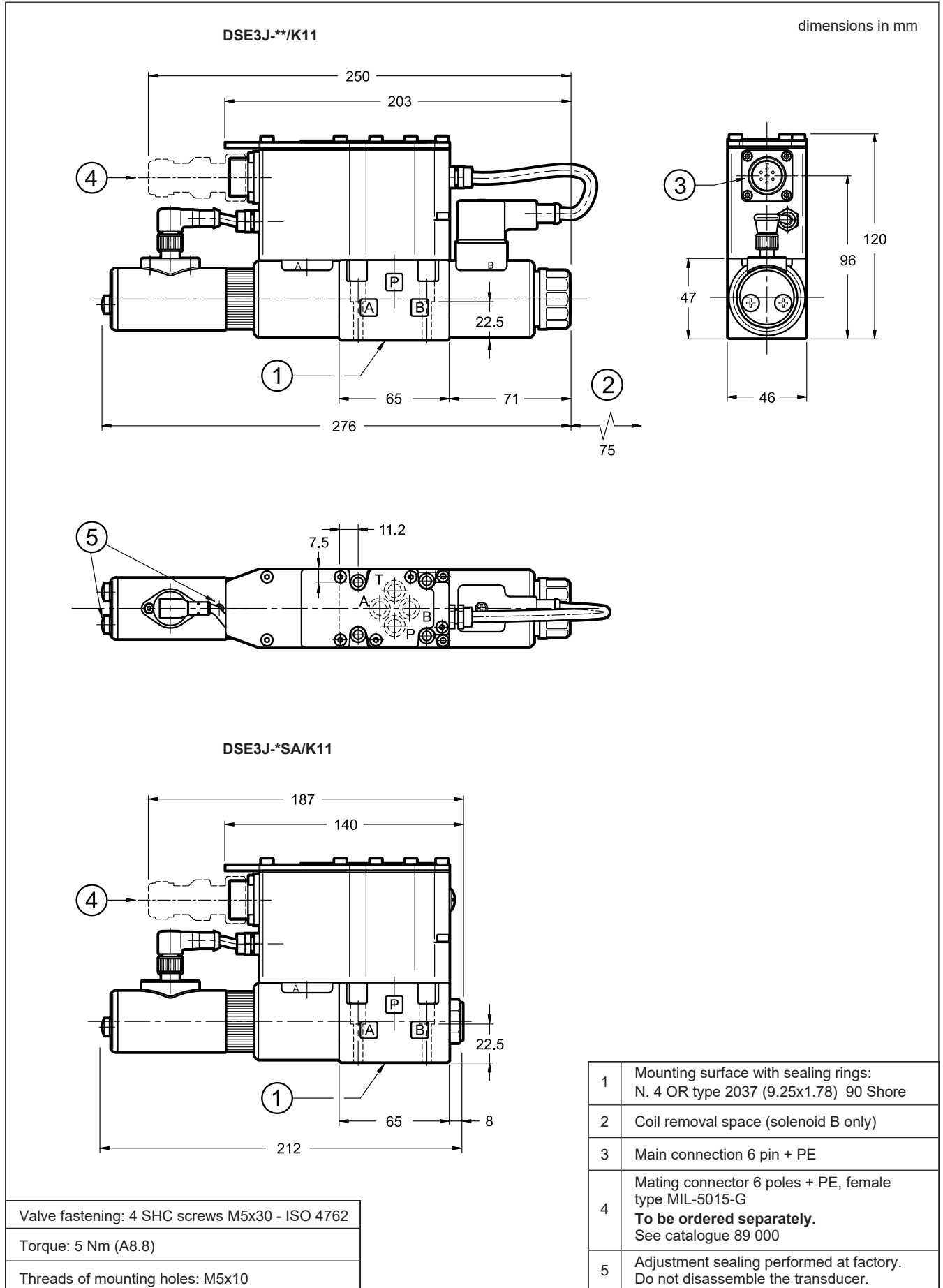

9 - DSE3JL - OVERALL AND MOUNTING DIMENSIONS

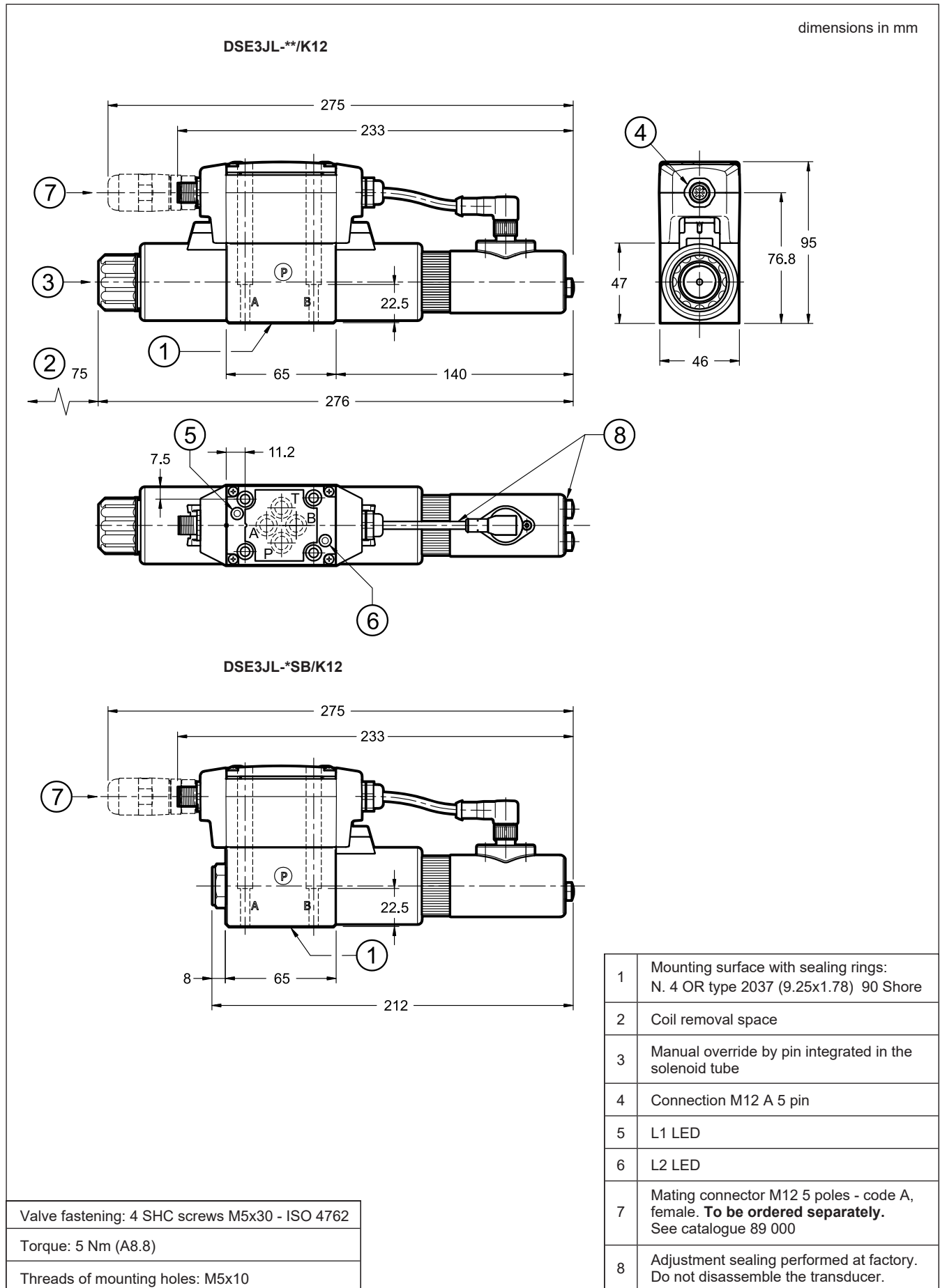

10 - DSE3JH - OVERALL AND MOUNTING DIMENSIONS

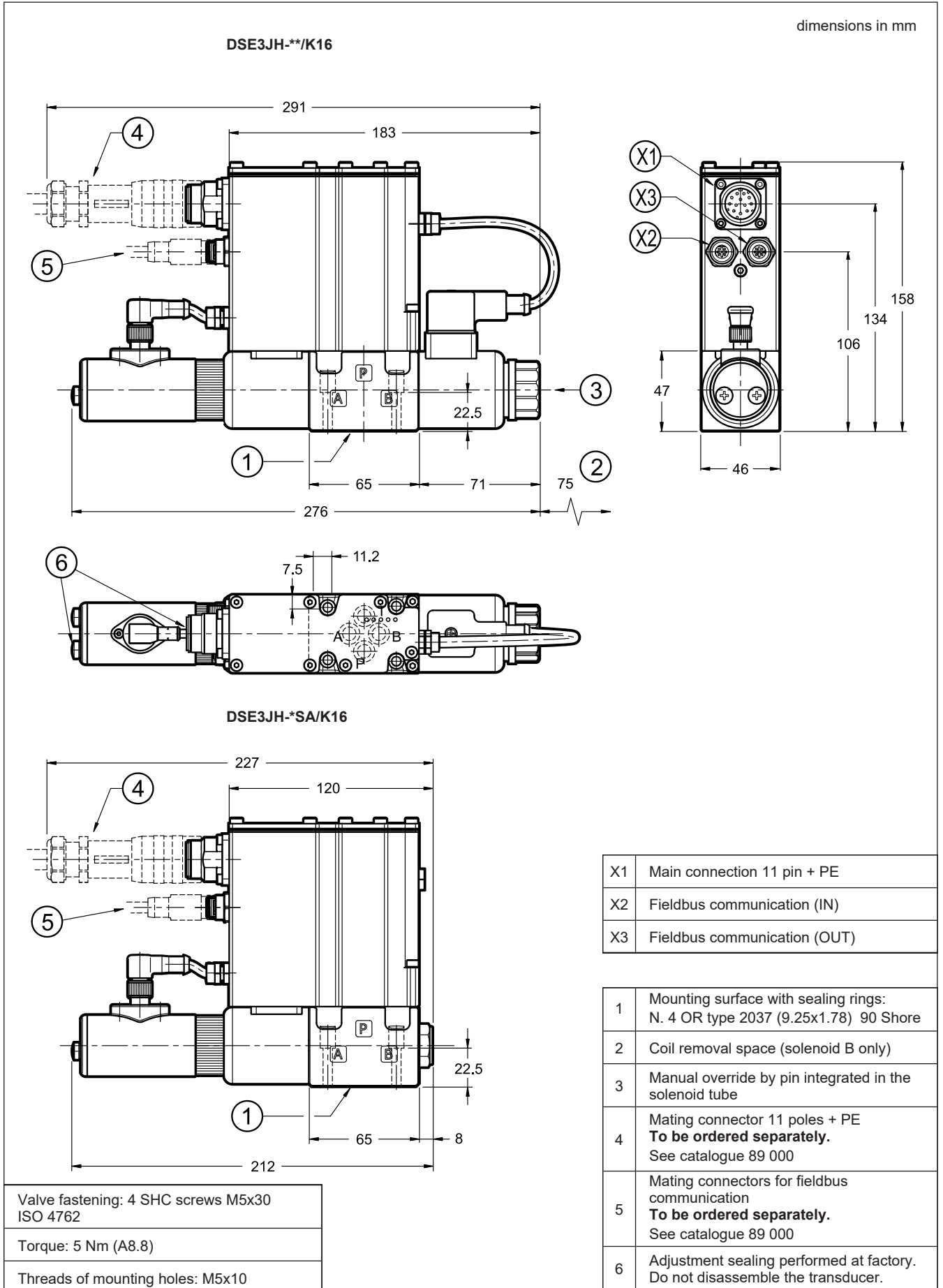

11 - HYDRAULIC FLUIDS

Use mineral oil-based hydraulic fluids HL or HM type, according to ISO 6743-4. For these fluids, use NBR seals. For fluids HFDR type (phosphate esters) use FPM seals (code V). For the use of other kinds of fluid such as HFA, HFB, HFC, please consult our technical department.

Using fluids at temperatures higher than 80 °C causes a faster degradation of the fluid and of the seals characteristics.

The fluid must be preserved in its physical and chemical characteristics.

12 - INSTALLATION

DSE3J valves can be installed in any position without impairing correct operation.

Ensure that there is no air in the hydraulic circuit.

Valves are fixed by means of screws or tie rods on a flat surface with planarity and roughness equal to or better than those indicated in the relative symbols. If minimum values are not observed, fluid can easily leak between the valve and support surface.

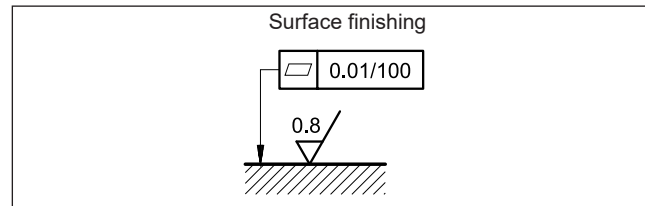

13 - ACCESSORIES

(to be ordered separately)

13.1 - Mating connectors

Mating connectors must be ordered separately. See catalogue 89 000.



For K11 and K16 versions we recommend the choice of a metal connector to avoid electromagnetic disturbances and to comply with EMC regulations on electromagnetic compatibility. If you opt for a plastic connector, make sure that it guarantees and maintains the IP and EMC protection characteristics of the valve.

13.2 - Mating connectors and caps for fieldbus communication

Duplomatic offers spare parts to be wired and also ready-to-use cord sets. Please refer to cat. 89 000.

13.3 - Connection cable

The optimal wiring provides for 7 isolated conductors, with separate screen for the signal wires (command, monitor) and an overall screen.

Cross section for power supply:

- up to 20 m cable length : 1,0 mm²
- up to 40 m cable length : 1,5 mm² (IO-Link excluded)

Cross section for signals (command, monitor):

- 0,50 mm²

13.4 - Kit for start-up LINPC-USB

Device for service start-up and diagnostic. See catalogue 89 850.

14 - SUBPLATES

(see catalogue 51 000)

PMMD-AI3G rear ports
PMMD-AL3G side ports
Ports dimensions: P, T, A, B: 3/8" BSP