



DSE3G*

PROPORTIONAL DIRECTIONAL VALVE WITH DIGITAL INTEGRATED ELECTRONICS

SUBPLATE MOUNTING
ISO 4401-03

p max 350 bar
Q max 40 l/min

MOUNTING INTERFACE

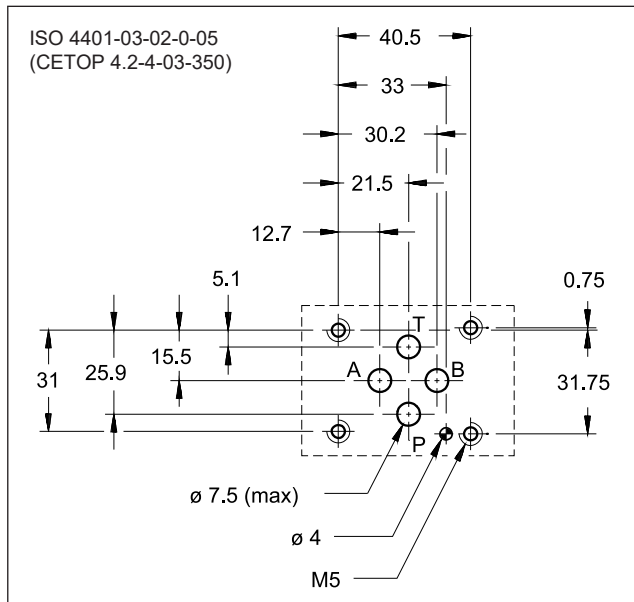

OPERATING PRINCIPLE

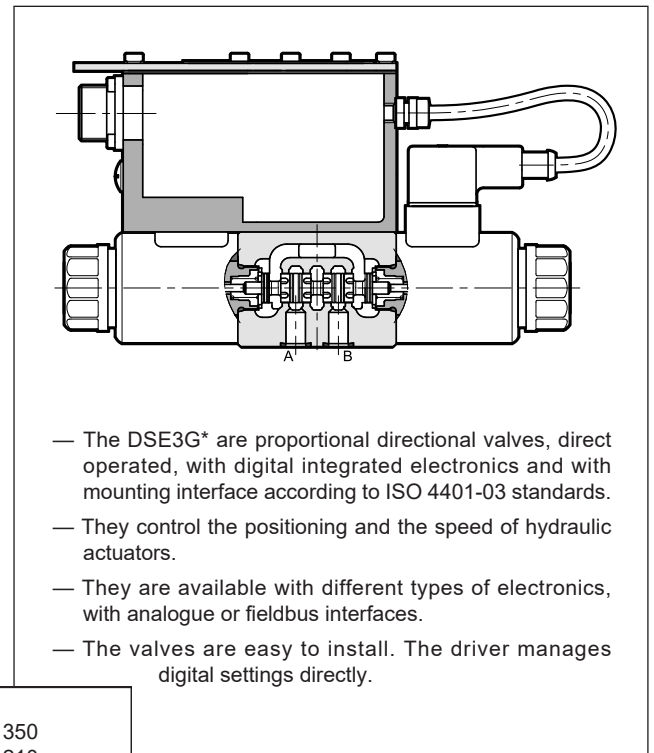

PERFORMANCES

(obtained with mineral oil with viscosity of 36 cSt at 50°C and p = 140 bar)

Max operating pressure: - P - A - B ports - T port	bar	350 210
Nominal flow with Δp 10 bar P-T	l/min	1 - 4 - 8 - 16 - 26
Response times	see point 6	
Hysteresis	% of Q max	< 3%
Repeatability	% of Q max	< $\pm 1\%$
Electrical characteristics	see points 3 and 4	
Ambient temperature range	°C	-20 / +60
Fluid temperature range	°C	-20 / +80
Fluid viscosity range	cSt	10 ÷ 400
Fluid contamination degree	according to ISO 4406:1999 class 18/16/13	
Recommended viscosity	cSt	25
Mass: single solenoid valve double solenoid valve	kg	1.9 2.4

HYDRAULIC SYMBOLS (typical)

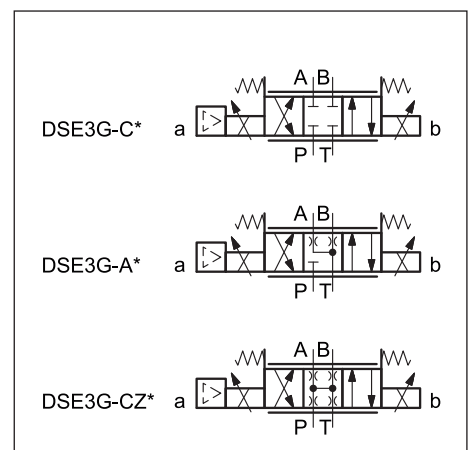

1 - IDENTIFICATION CODES AND CONFIGURATION

1.1 - Standard electronics

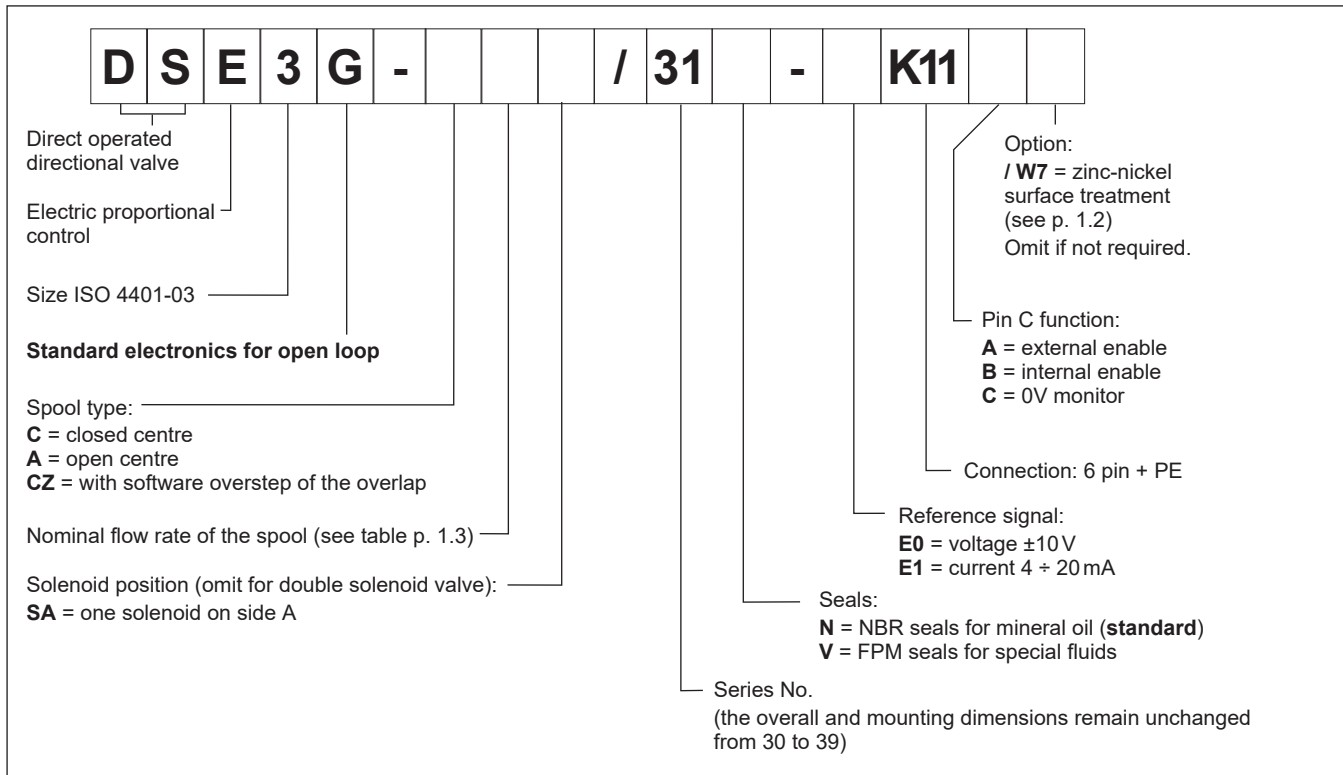

1.2 - Surface treatments

The standard valve is supplied with surface treatment of phosphating black. The zinc-nickel finishing on the valve body makes the valve suitable to ensure a salt spray resistance up to 240 hours. (test operated according to UNI EN ISO 9227 standards and test evaluation operated according to UNI EN ISO 10289 standards).

1.3 - Configurations

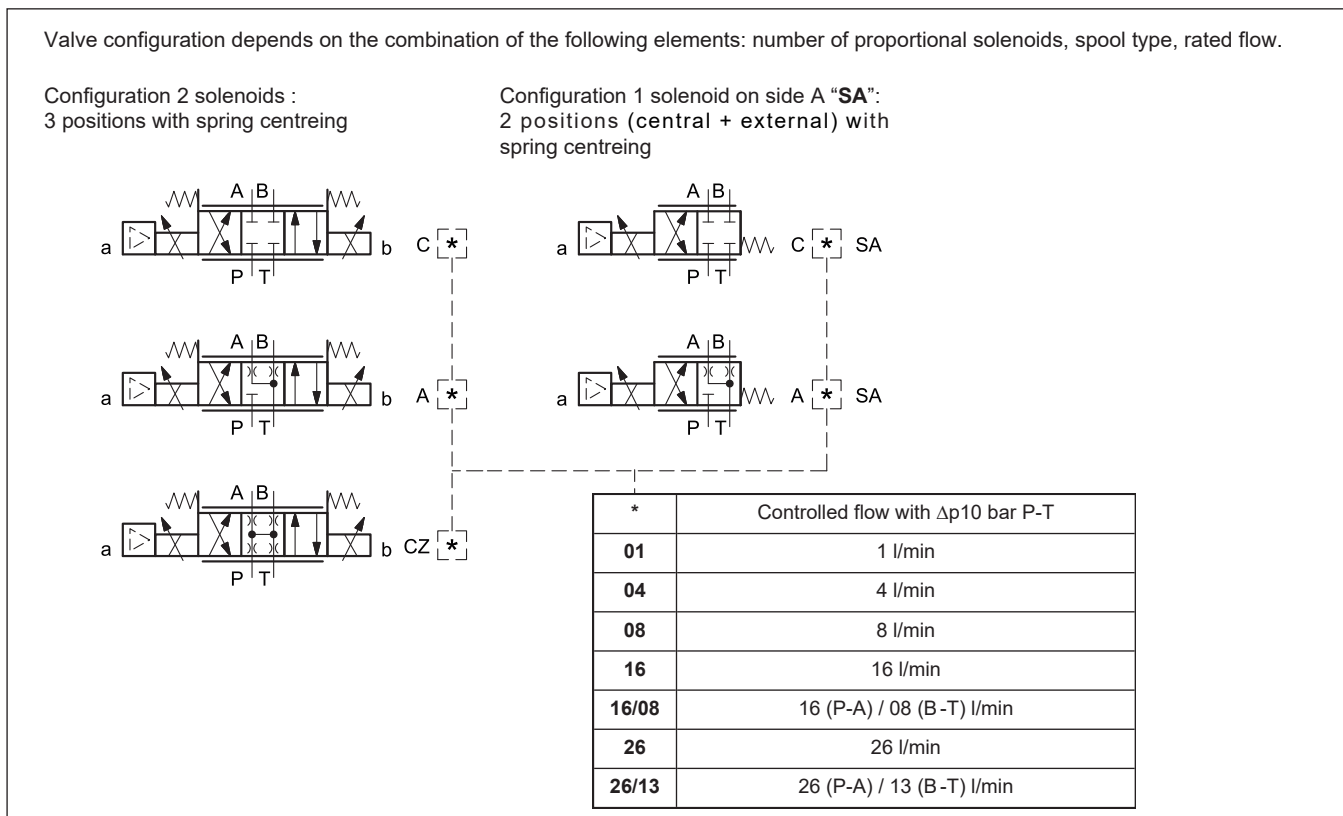

2 - ELECTRONICS COMMON DATA

Duty cycle		100% (continuous operation)
Protection class according to EN 60529		IP65/IP67 (NOTE)
Supply voltage	V DC	24 (from 19 to 30 VDC), ripple max 3 Vpp
Power consumption	VA	25
Maximum solenoid current	A	1.88
Fuse protection, external	A	3
Managed breakdowns		Overload and electronics overheating, cable breakdown, supply voltage failures
Electromagnetic compatibility (EMC) emissions EN 61000-6-4, immunity EN 61000-6-2		According to 2014/30/EU standards

NOTE: The IP degree is guaranteed only with mating connector of equivalent IP degree, installed and tightened correctly. Moreover, on the GH versions it is necessary to protect any unused connections with caps.

3 - DSE3G - STANDARD ELECTRONICS

3.1 - Electrical characteristics

Command signal:	voltage (E0) current (E1)	V DC mA	± 10 (impedance $R_i > 11 \text{ k}\Omega$) $4 \div 20$ (impedance $R_i = 58 \text{ }\Omega$)
Monitor signal (current to solenoid):	voltage (E0) current (E1)	V DC mA	± 10 (impedance $R_o > 1 \text{ k}\Omega$) $4 \div 20$ (impedance $R_o = 500 \text{ }\Omega$)
Communication for diagnostic			LIN-bus Interface (by means of the optional kit)
Connection			6 pin + PE (MIL-C-5015-G - DIN EN 175201-804)

3.2 - On-board electronics diagrams

VERSION A - External Enable

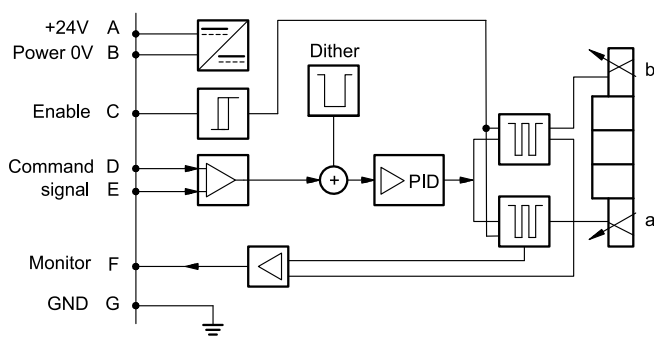

VERSION B - Internal Enable

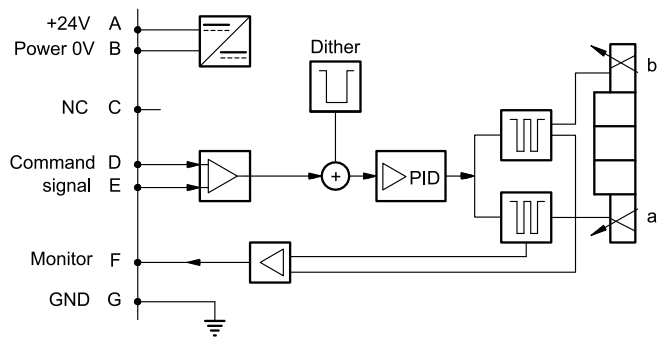

VERSION C - 0V Monitor

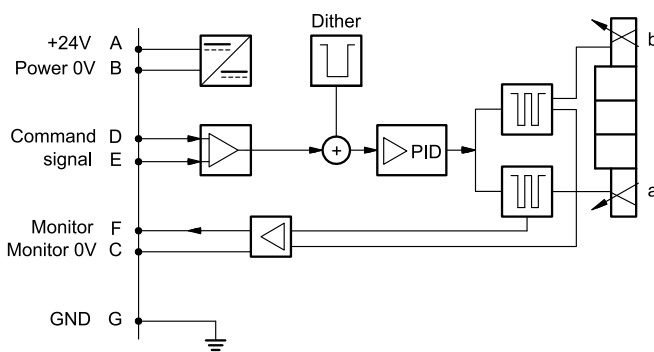

3.3 - Versions with voltage command (E0)

The reference signal is between -10V and +10V on double solenoid valve, and 0 + 10V on single solenoid valve SA. The monitor feature of versions B and C becomes available with a delay of 0.5 sec from the power-on of the card.

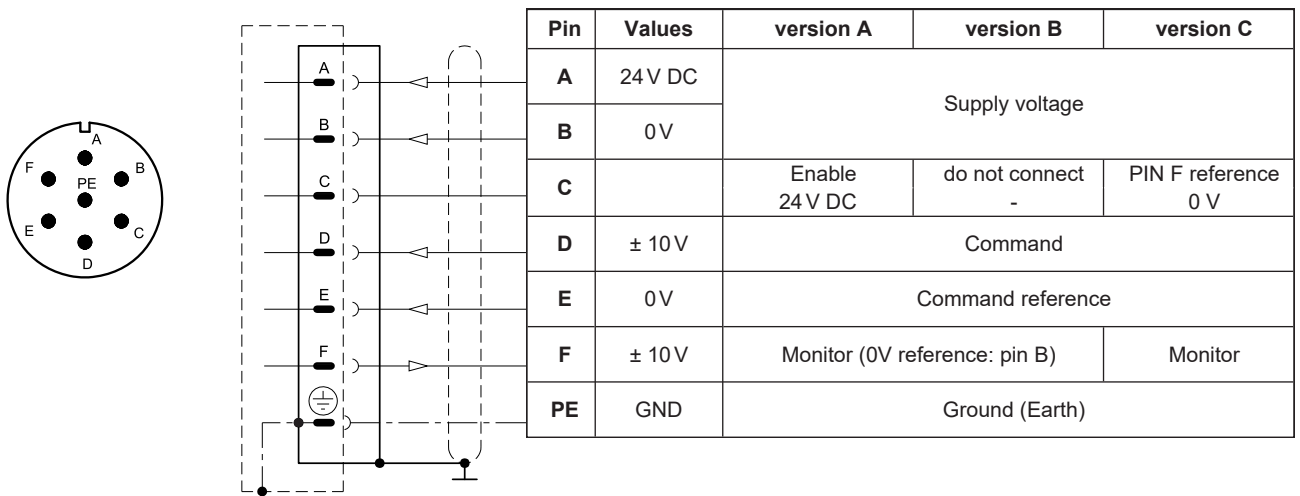
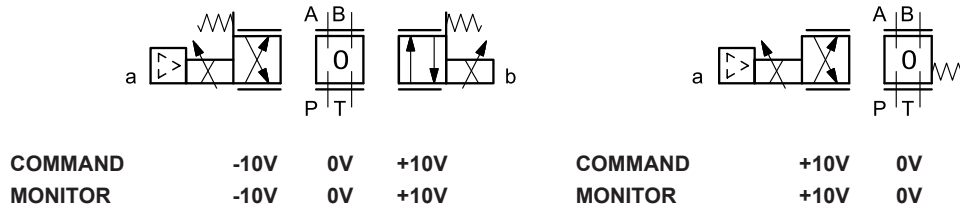

3.4 - Versions with current command (E1)

The reference signal is supplied in current 4 + 20 mA. If the current for command is lower, the card shows a breakdown cable error. To reset the error is sufficient restoring the signal.

The monitor feature of versions B and C becomes available with a delay of 0.5 sec from the power-on of the card.

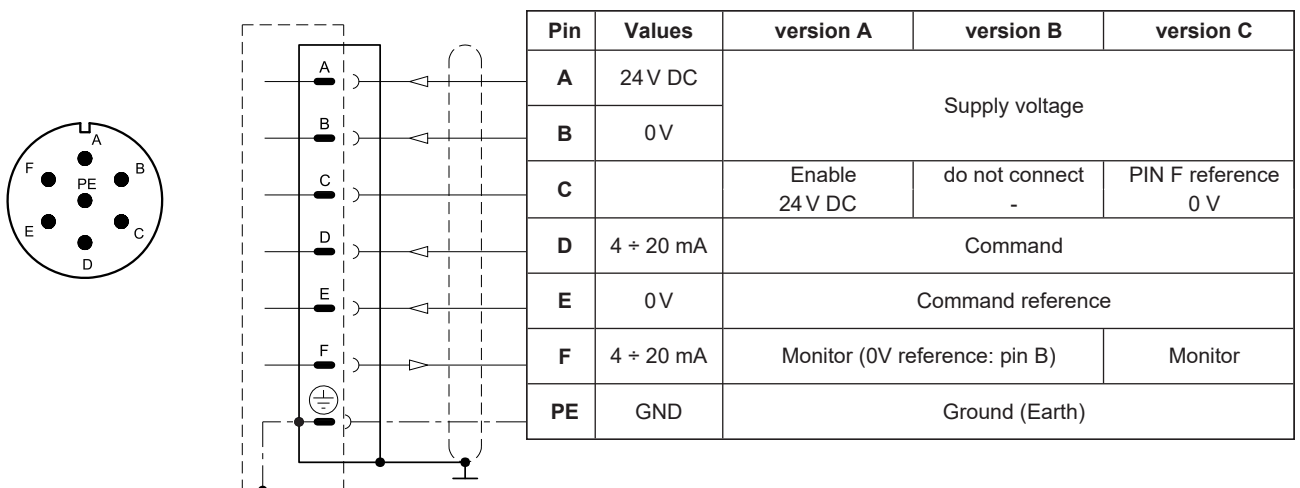
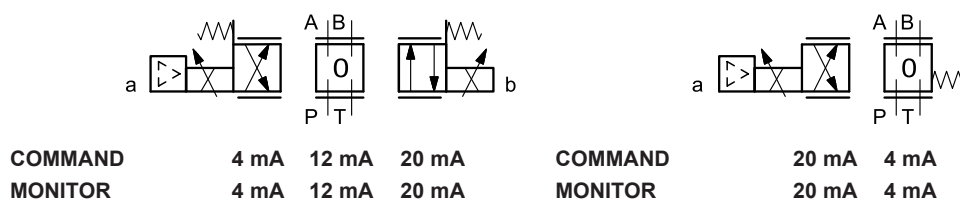

4 - DSE3GL - COMPACT ELECTRONICS

In IO-Link networks, the length of the connecting cables is limited to 20 metres. In CA versions, pin 3 and pin 5 are galvanic isolated up to 100 V to avoid earth loops.

4.1 - Electrical characteristics

Command signal: voltage (E0) current (E1)	V DC mA	± 10 (impedance $R_i > 11 \text{ k}\Omega$) $4 \div 20$ (impedance $R_i = 58 \text{ }\Omega$)
Monitor signal (current to solenoid): voltage (E0) current (E1)	V DC mA	$0 \div 5$ (impedance $R_o > 1 \text{ k}\Omega$) $4 \div 20$ (impedance $R_o = 500 \text{ }\Omega$)
IO-Link communication (IOL): Data rate	kBaud	IO-Link Port Class B 38.4
Can Open communication (CA): Data rate	kbit	$10 \div 1000$
Data register (IOL and CA versions only)		card voltage supply, solenoid faults (shortcircuit, bad configuration), box temperature.
Connection		5-pin M12 code A (IEC 61076-2-101)

4.2 - Pin tables

'E0' connection

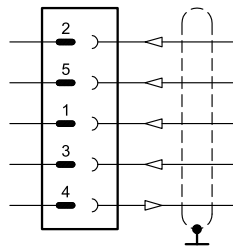

Pin	Values	Function
2	24 V DC	Supply voltage (solenoid and logic)
5	0 V	
1	$\pm 10 \text{ V}$	Command
3	0 V	Command reference
4	$0 \div 5 \text{ V}$	Monitor (0 V reference: pin 5)

'E1' connection

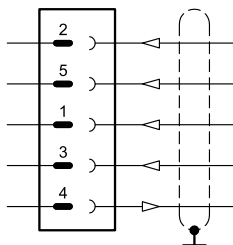

Pin	Values	Function
2	24 V DC	Supply voltage (solenoid and logic)
5	0 V	
1	$4 \div 20 \text{ mA}$	Command
3	0 V	Command reference
4	$4 \div 20 \text{ mA}$	Monitor (0 V reference: pin 5)

'IOL' connection

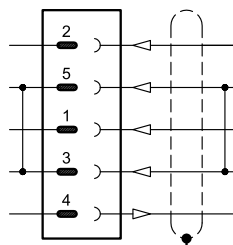

Pin	Values	Function
2	2L+ 24 V DC	Solenoid supply voltage
5	2L- 0 V (GND)	
1	1L+ +24 V DC	Logic and IO-Link supply voltage
3	1L- 0 V (GND)	
4	C/Q	IO-Link Communication

NOTE: Pin 3 and pin 5 are linked with each other in the valve electronics. The reference potentials 1L- and 2L- of the two supply voltages must also be linked with each other on the customer side.

'CA' connection

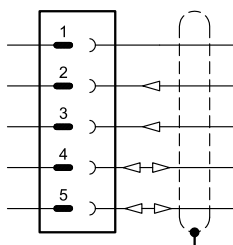

Pin	Values	Function
1	CAN_SH	Shield
2	24 V DC	Supply voltage
3	0 V (GND)	
4	CAN_H	Bus line (high)
5	CAN_L	Bus line (low)

5 - DSE3GH - FIELD BUS ELECTRONICS

The 11+ PE pin connection allows separate supply voltage for electronics and solenoids.

Command - valve position schemes as for the standard electronics. Please refer to pictures in par. 3.3 and 3.4.

5.1 - Electrical characteristics

Command signal: voltage (E0) current (E1) digital (FD)	V DC mA	± 10 (impedance $R_i > 11 \text{ k}\Omega$) $4 \div 20$ (impedance $R_i = 58 \text{ }\Omega$) via fieldbus
Monitor signal (current to solenoid): voltage (E0) current (E1)	V DC mA	± 10 (impedance $R_o > 1 \text{ k}\Omega$) $4 \div 20$ (impedance $R_o = 500 \text{ }\Omega$)
Communication / diagnostic		via Bus register
Communication interface standard		IEC 61158
Communication physical layer		fast ethernet, insulated 100 Base TX
Power connection		11 pin + PE (DIN 43651)

5.2 - X1 Main connection pin table

D1: one command

Pin	Values	Function
1	24 V DC	Main supply voltage
2	0 V	
3	24V DC	Enable
4	$\pm 10 \text{ V (E0)}$ $4 \div 20 \text{ (E1)}$	Command
5	0 V	Command reference signal
6	$\pm 10 \text{ V (E0)}$ $4 \div 20 \text{ (E1)}$	Monitor (0V reference pin 10)
7	NC	do not connect
8	NC	do not connect
9	24 V DC	Logic and control supply
10	0 V	
11	24 V DC	Fault (0V DC) or normal working (24V DC) (0V reference pin 2)
12	GND	Ground (Earth)

D0: full digital

Pin	Values	Function
1	24 V DC	Main supply voltage
2	0 V	
3	24V DC	Enable
4	NC	do not connect
5	NC	do not connect
6	NC	do not connect
7	NC	do not connect
8	NC	do not connect
9	24 V DC	Logic and control supply
10	0 V	
11	24 V DC	Fault (0V DC) or normal working (24V DC) (0V ref. pin 2)
12	GND	Ground (Earth)

5.3 - FIELD BUS connections

Please wire following guidelines provided by the related standards communication protocol. Any connections present and not used must be protected with special caps so as not to nullify the protection against atmospheric agents.

X2 (IN) connection: M12 D 4 pin female



Pin	Values	Function
1	TX+	Transmitter
2	RX+	Receiver
3	TX-	Transmitter
4	RX-	Receiver
HOUSING	shield	

X3 (OUT) connection: M12 D 4 pin female



Pin	Values	Function
1	TX+	Transmitter
2	RX+	Receiver
3	TX-	Transmitter
4	RX-	Receiver
HOUSING	shield	

NOTE: Shield connection on connector housing is recommended.

6 - CHARACTERISTIC CURVES

(obtained with mineral oil with viscosity of 36 cSt at 50°C and p = 140 bar)

Typical flow rate curves at constant Δp related to the reference signal and measured for the available spools. The Δp values are measured between P and T valve ports.

Curves obtained after linearization of the characteristic curve in factory, through the digital amplifier. The linearization of the curve is performed with a constant Δp of 5 bar and by setting the value of flow start at 20% of the reference signal.

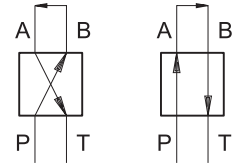

SPOOL TYPE C01/A01

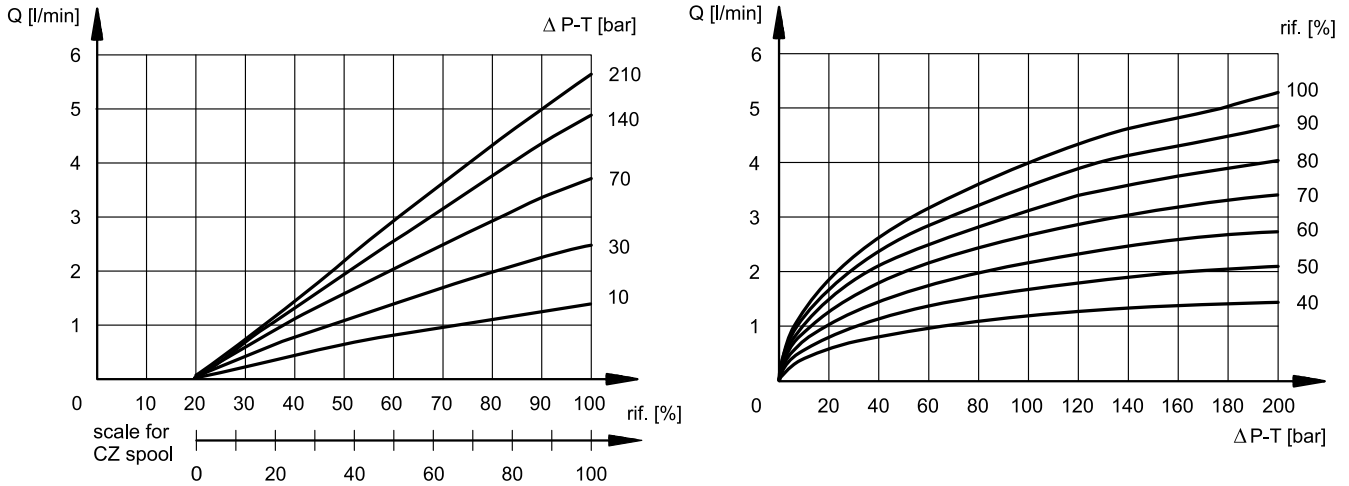

SPOOL TYPE C04/A04

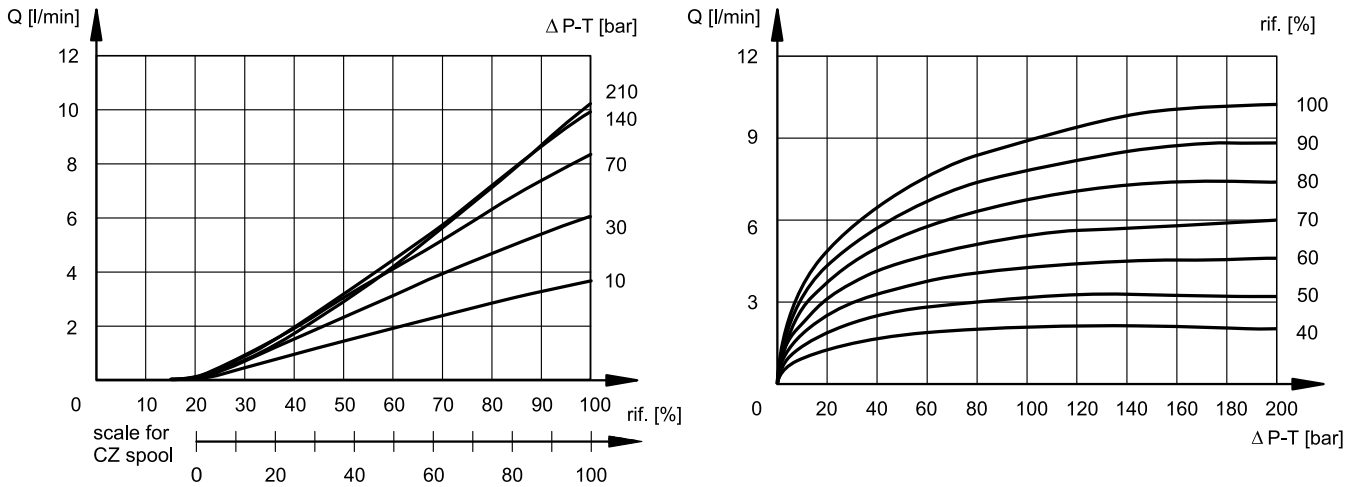

SPOOL TYPE C08/A08

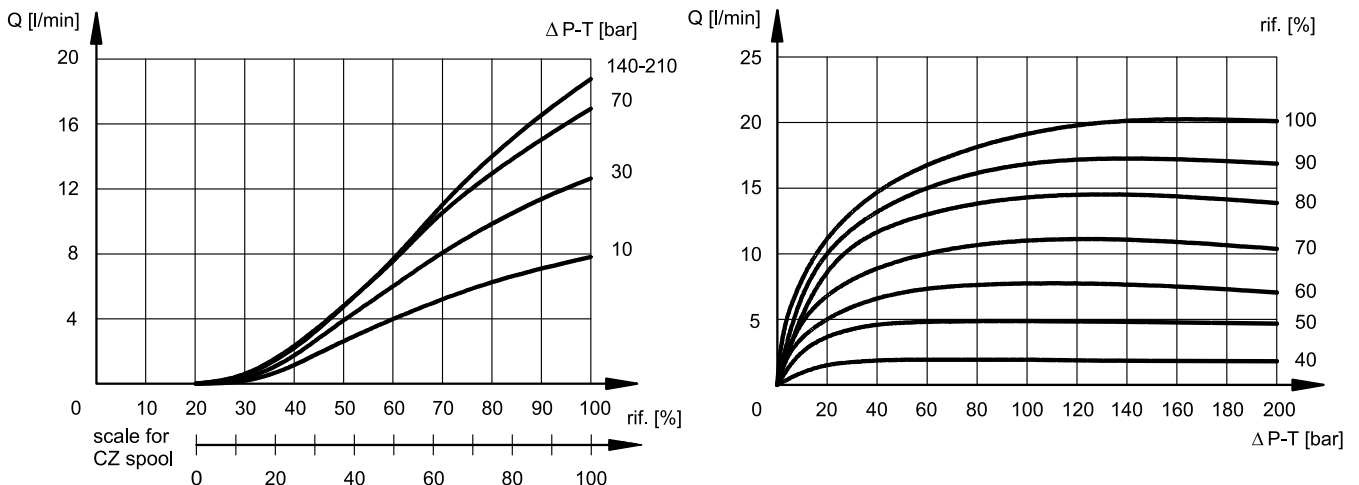

SPOOL TYPE C16/A16

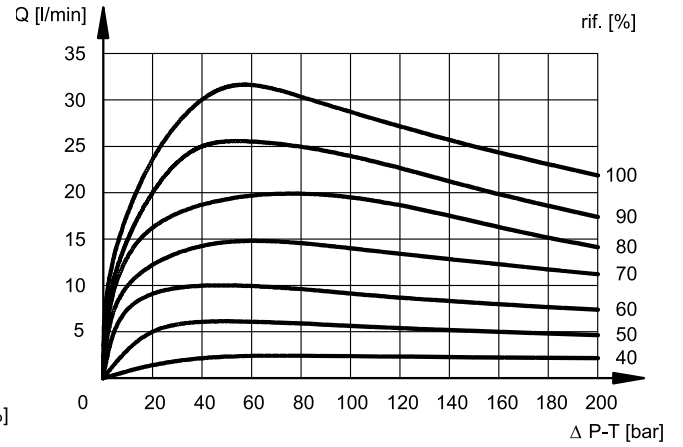
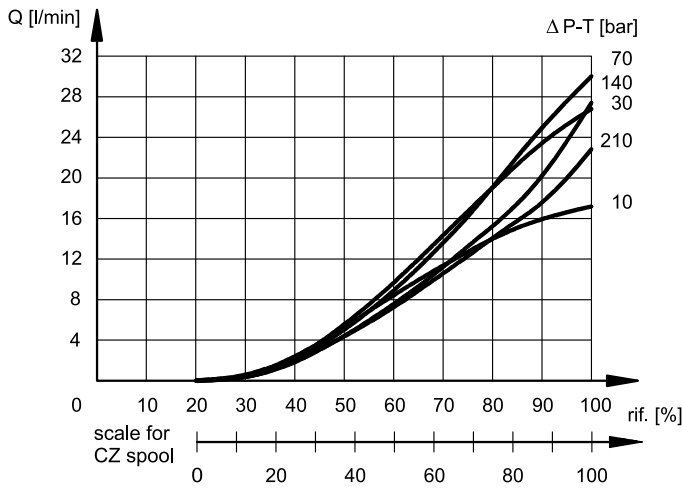

SPOOL TYPE C26/A26

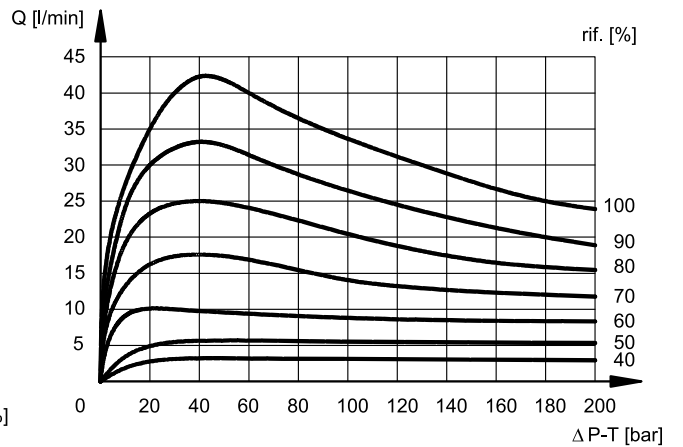
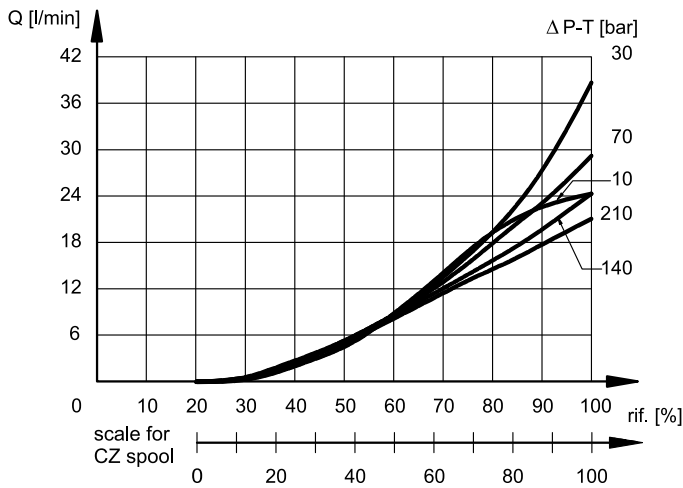

7 - RESPONSE TIMES

(obtained with mineral oil with viscosity of 36 cSt at 50°C and p = 140 bar)

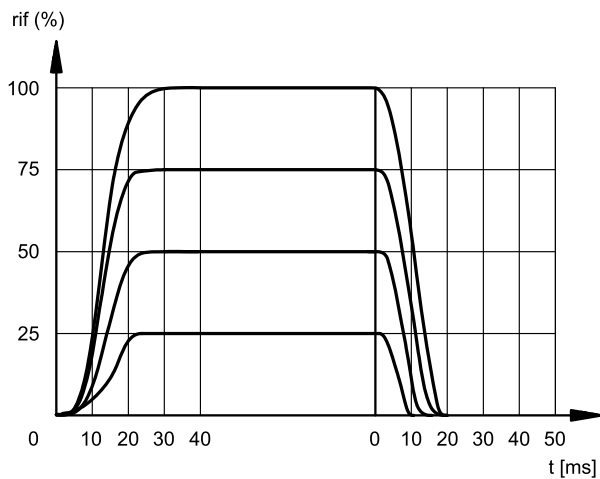

8 - DSE3G - OVERALL AND MOUNTING DIMENSIONS

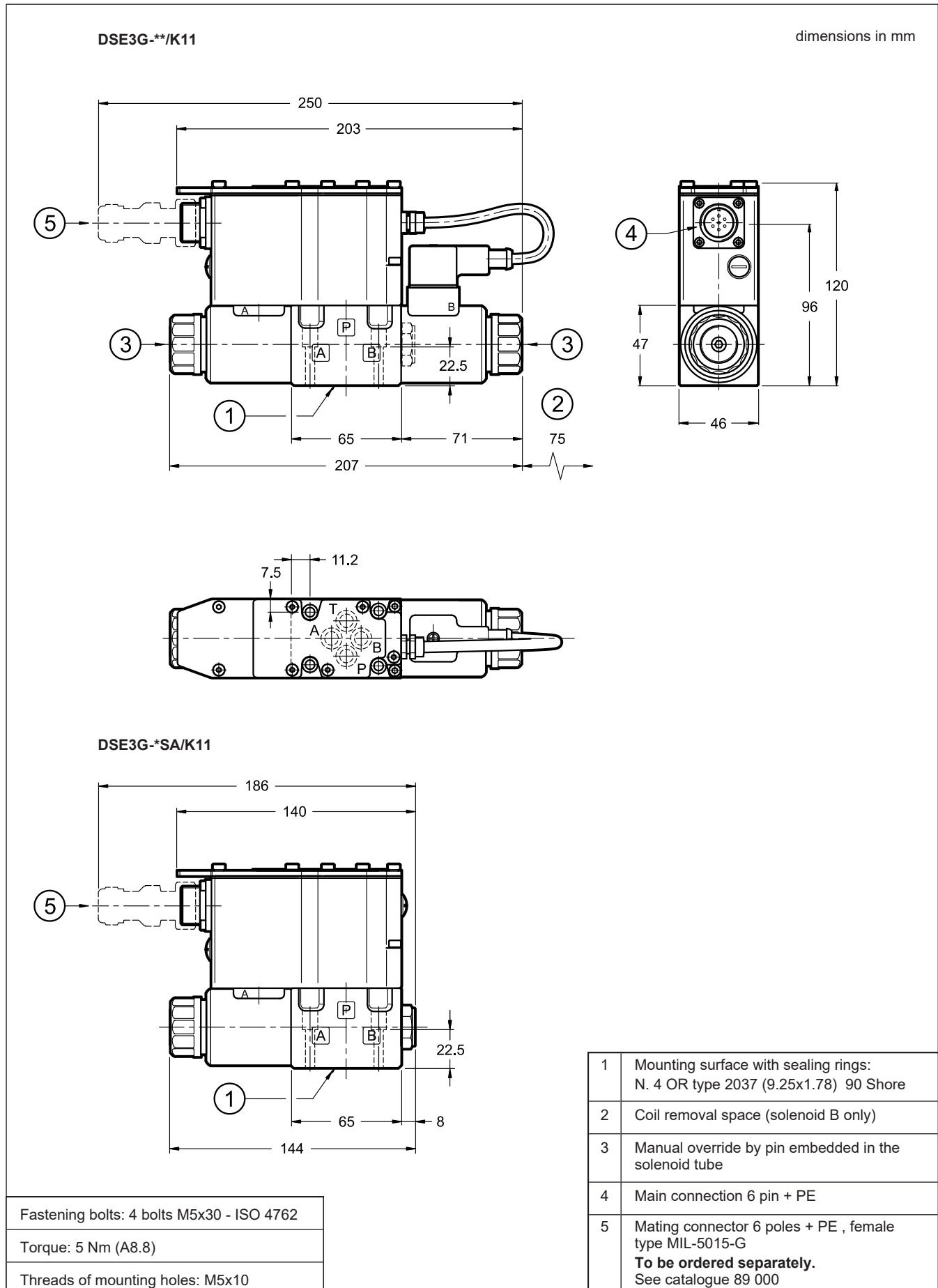

9 - DSE3GL - OVERALL AND MOUNTING DIMENSIONS

DSE3GL-*/K12

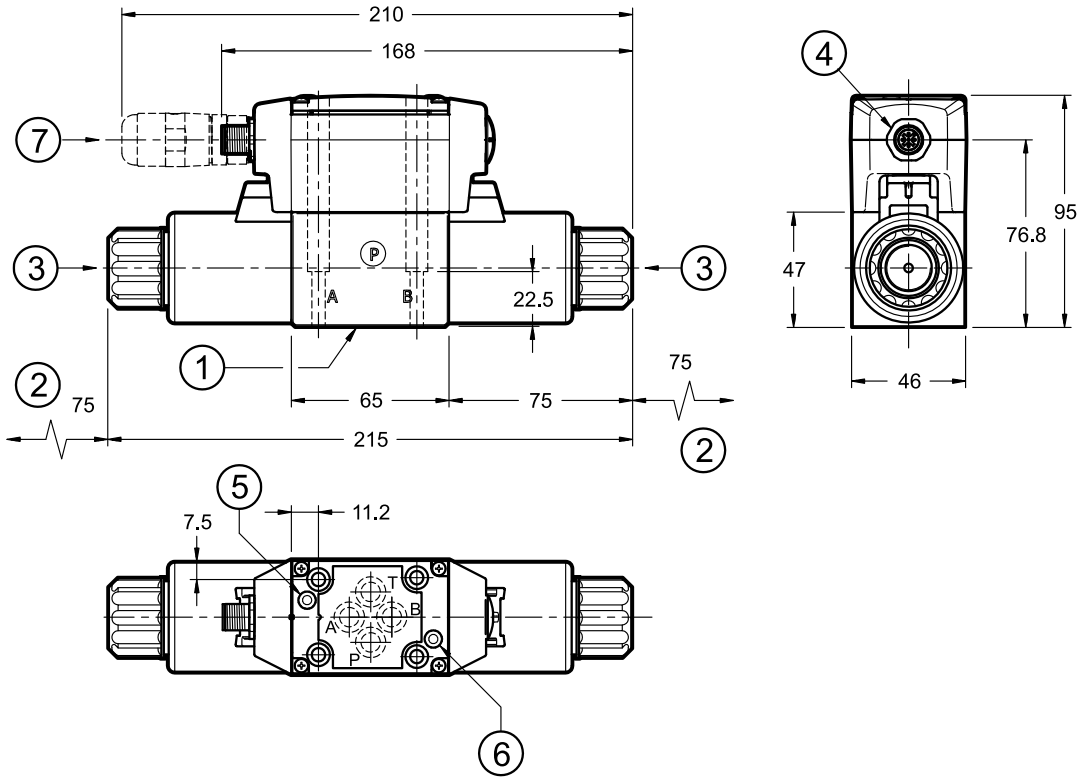

DSE3GL-*/SA/K12

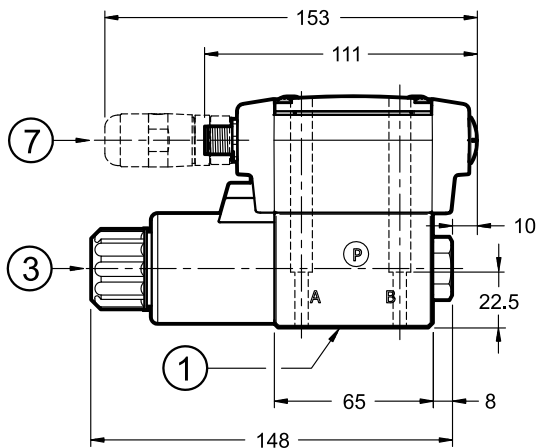

Fastening bolts: 4 bolts M5x30- ISO 4762

Torque: 5 Nm (A8.8)

Threads of mounting holes: M5x10

1	Mounting surface with sealing rings: N. 4 OR type 2037 (9.25x1.78) 90 Shore
2	Coil removal space
3	Standard manual override embedded in the solenoid tube
4	Connection M12 A 5 pin
5	L1 LED
6	L2 LED
7	Mating connector M12 5 poles - code A, female To be ordered separately. See catalogue 89 000

10 - DSE3GH - OVERALL AND MOUNTING DIMENSIONS

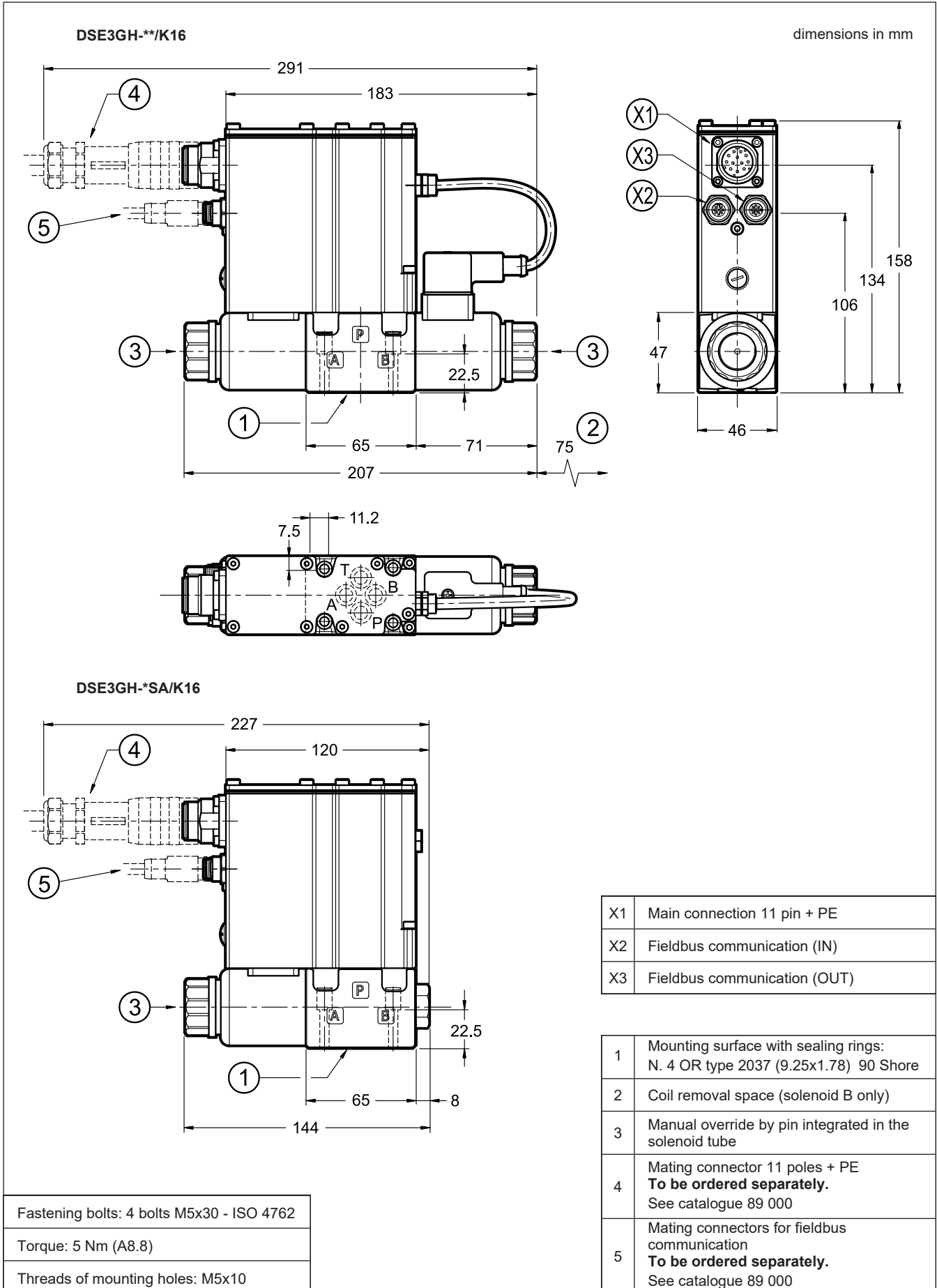

11 - MANUAL OVERRIDES

These valves have solenoids whose pin for manual operation is integrated in the tube. Actuate this override by pushing it with a suitable tool, minding not to damage the sliding surface.

Three other types of manual overrides can fit the DSE3GL valve:

- **CM** version, manual override boot protected
- **CK1** version, turning knob override.
- **CS** version, with metal ring nut provided with a M8 screw and locknut.

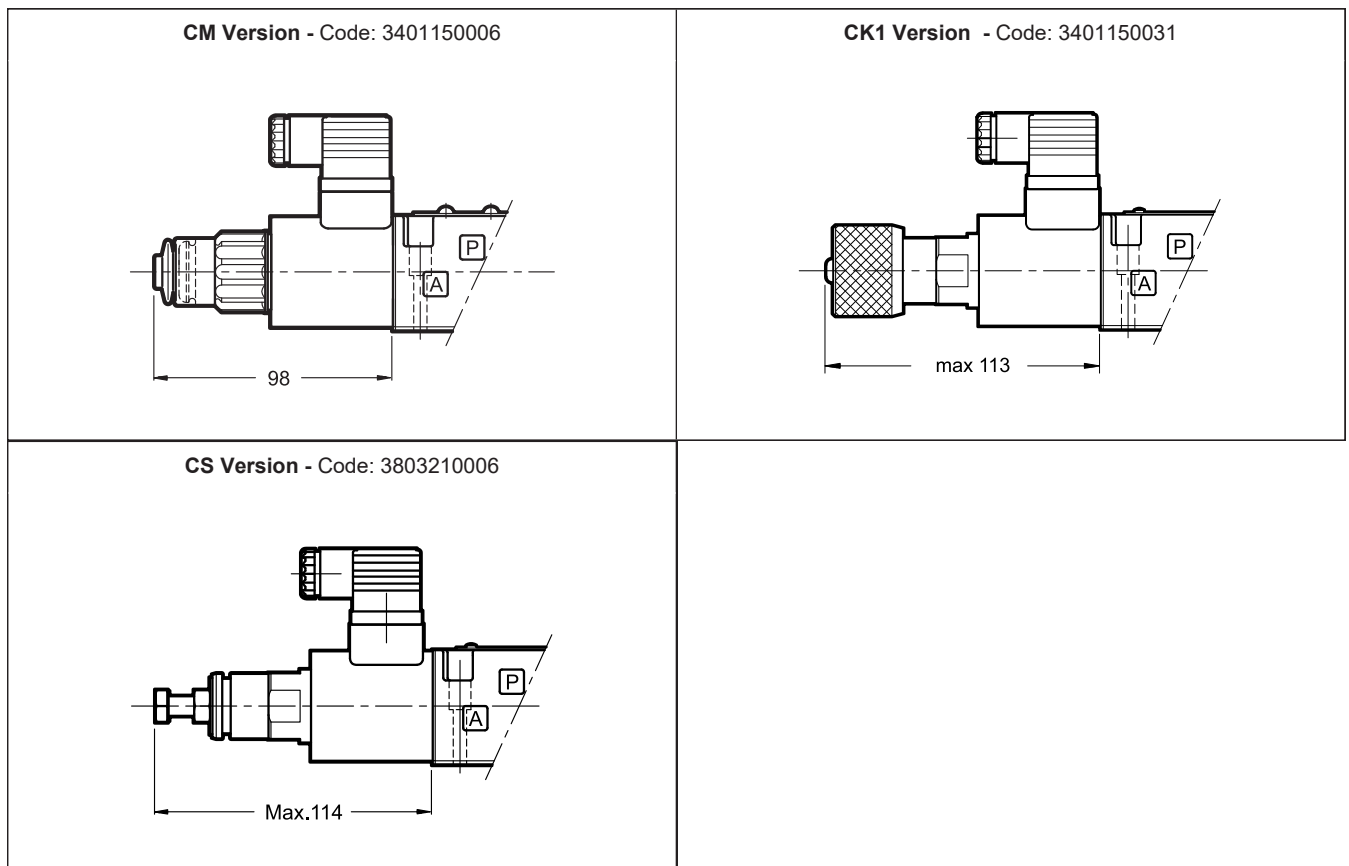

12 - HYDRAULIC FLUIDS

Use mineral oil-based hydraulic fluids HL or HM type, according to ISO 6743-4. For these fluids, use NBR seals. For fluids HFDR type (phosphate esters) use FPM seals (code V). For the use of other kinds of fluid such as HFA, HFB, HFC, please consult our technical department.

Using fluids at temperatures higher than 80 °C causes a faster degradation of the fluid and of the seals characteristics. The fluid must be preserved in its physical and chemical characteristics.

13 - INSTALLATION

DSE3G* valves can be installed in any position without impairing correct operation. Ensure that there is no air in the hydraulic circuit.

Valves are fixed by means of screws or tie rods on a lapped surface with planarity and roughness equal to or better than those indicated in the drawing.

If minimum values are not observed, fluid can easily leak between the valve and the mounting interface.

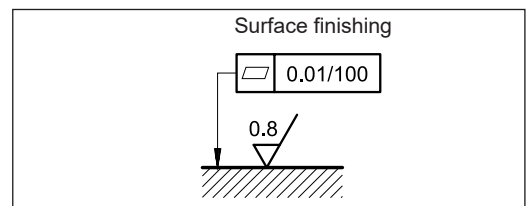



14 - ACCESSORIES

(to be ordered separately)

14.1 - Mating connectors

Mating connectors must be ordered separately. See catalogue 89 000.



For K11 and K16 versions we recommend the choice of a metal connector to avoid electromagnetic disturbances and to comply with EMC regulations on electromagnetic compatibility. If you opt for a plastic connector, make sure that it guarantees and maintains the IP and EMC protection characteristics of the valve.

14.2 - Mating connectors and caps for fieldbus communication

Diplomatic offers spare parts to be wired and also ready-to-use cord sets. Please refer to cat. 89 000.

14.3 - Connection cable

The optimal wiring provides for 7 isolated conductors, with separate screen for the signal wires (command, monitor) and an overall screen.

Cross section for power supply:

- up to 20 m cable length : 1,0 mm²
- up to 40 m cable length : 1,5 mm² (IO-Link excluded)

Cross section for signals (command, monitor):

- 0,50 mm²

14.4 - Kit for start-up LINPC-USB

Device for service start-up and diagnostic. See catalogue 89 850.

15 - SUBPLATES

(see catalogue 51 000)

PMMD-AI3G rear ports
PMMD-AL3G side ports
Ports dimensions: P, T, A, B: 3/8" BSP