

PZE3G*

PROPORTIONAL THREE-PORT PRESSURE REDUCING VALVE, PILOT OPERATED, WITH INTEGRATED ELECTRONICS

**SUBPLATE MOUNTING
ISO 4401-03**

**p max 350 bar
Q max 40 l/min**

MOUNTING SURFACE

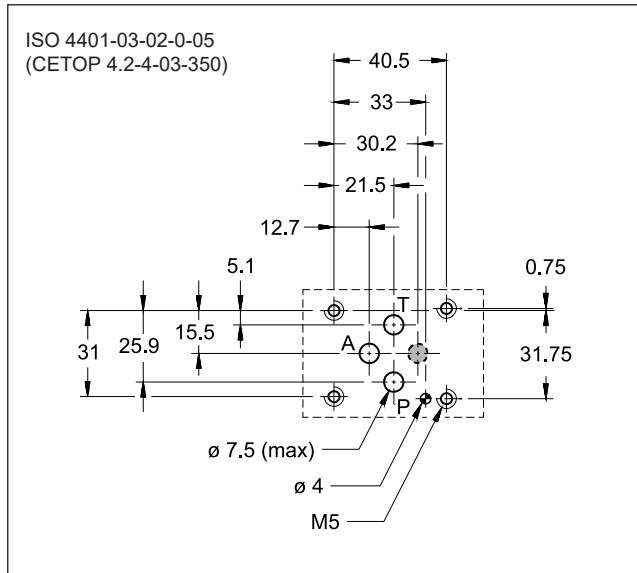

OPERATING PRINCIPLE

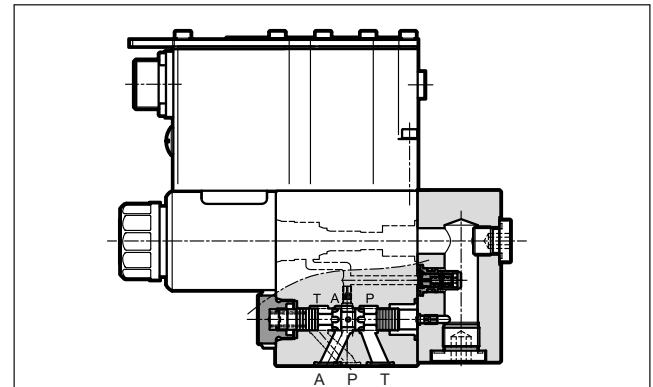

- PZE3G* valve is a proportional three-port pressure reducing valve, pilot operated, with on-board electronics with mounting surface according to ISO 4401-03 standards.
- This valve controls the outlet pressure on port A, reducing the inlet pressure from line P or relieving the overpressure from line A into T keeping it at the set value. (typically: hydraulic counter-weight or load balancing)

PERFORMANCES

(obtained with mineral oil with viscosity of 36 cSt at 50°C and p = 140 bar)

Maximum operating pressure: - P port - T port	bar	350 2
Maximum flow (see p max = f(Q) diagram)	l/min	40
Step response	see point 7	
Hysteresis	% of p nom	< 3%
Repeatability	% of p nom	< ±1%
Electrical characteristic	see point 2	
Ambient temperature range	°C	-20 / +60
Fluid temperature range	°C	-20 / +80
Fluid viscosity range	cSt	10 ÷ 400
Fluid contamination degree	According to ISO 4406:1999 class 18/16/13	
Recommended viscosity	cSt	25
Mass	kg	2.7

- It is suitable to modulate the pressure in hydraulic circuits.
- It is available with different types of electronics, with analogue or fieldbus interfaces.
- Valves are easy to install. The driver directly manages digital settings.

HYDRAULIC SYMBOL

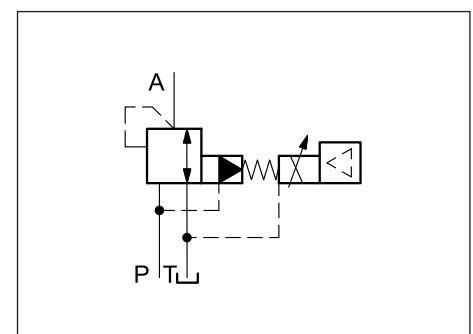

1 - IDENTIFICATION CODE

1.1 - Standard electronics

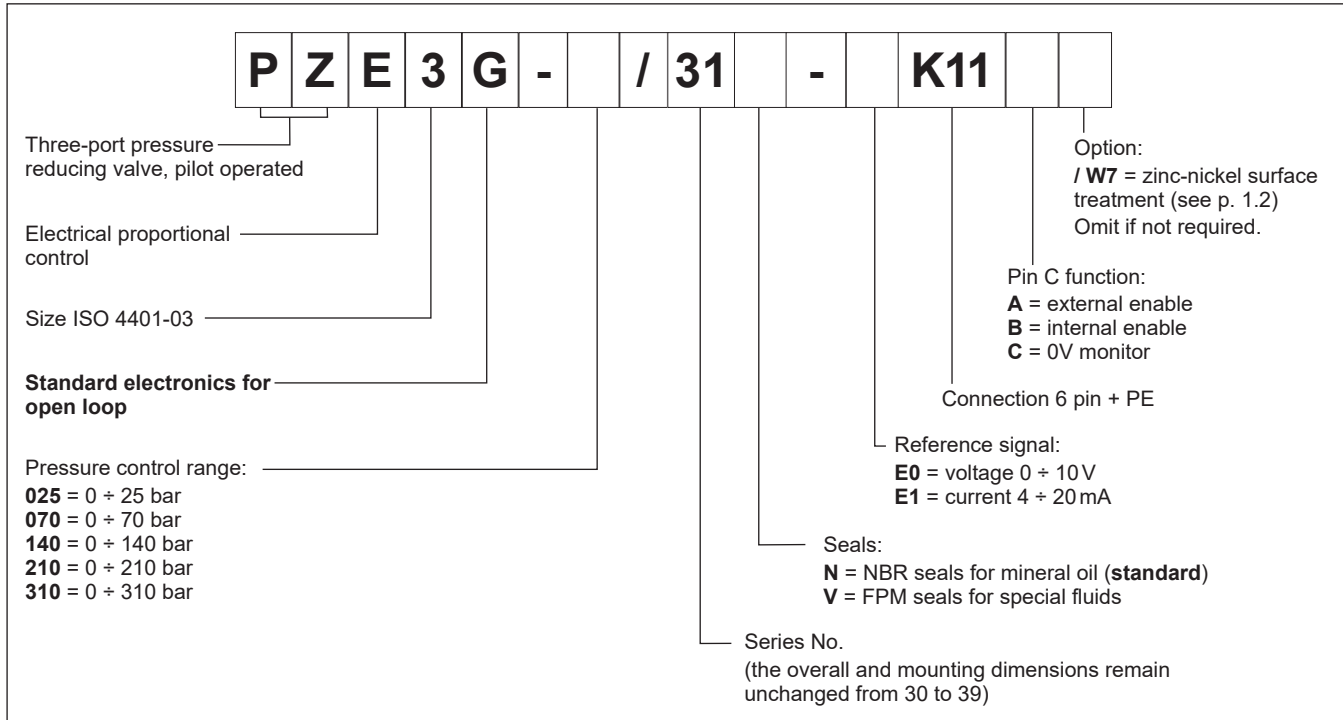

1.2 - Surface treatments

The standard valve is supplied with surface treatment of phosphating black. The zinc-nickel finishing on the valve body makes the valve suitable to ensure a salt spray resistance up to 240 hours. (test operated according to UNI EN ISO 9227 standards and test evaluation operated according to UNI EN ISO 10289 standards).

1.3 - Compact electronics

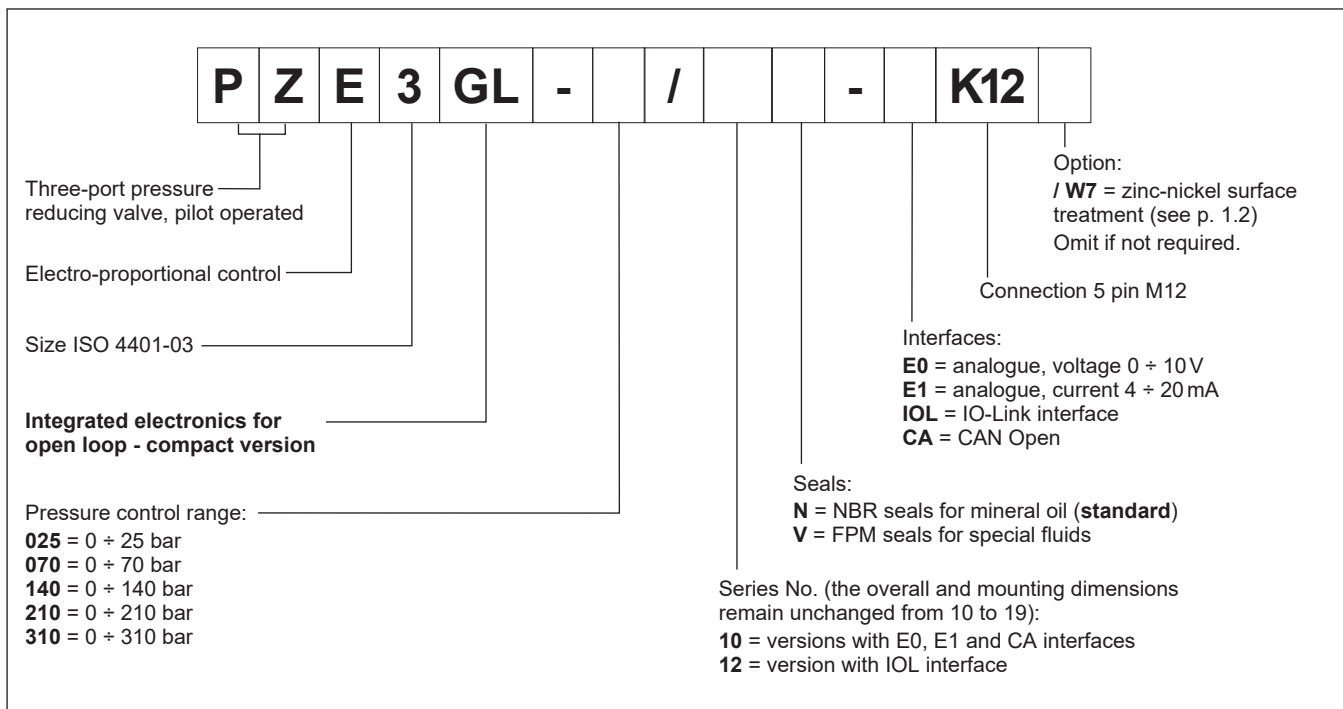

1.4 - Electronics with fieldbus communication

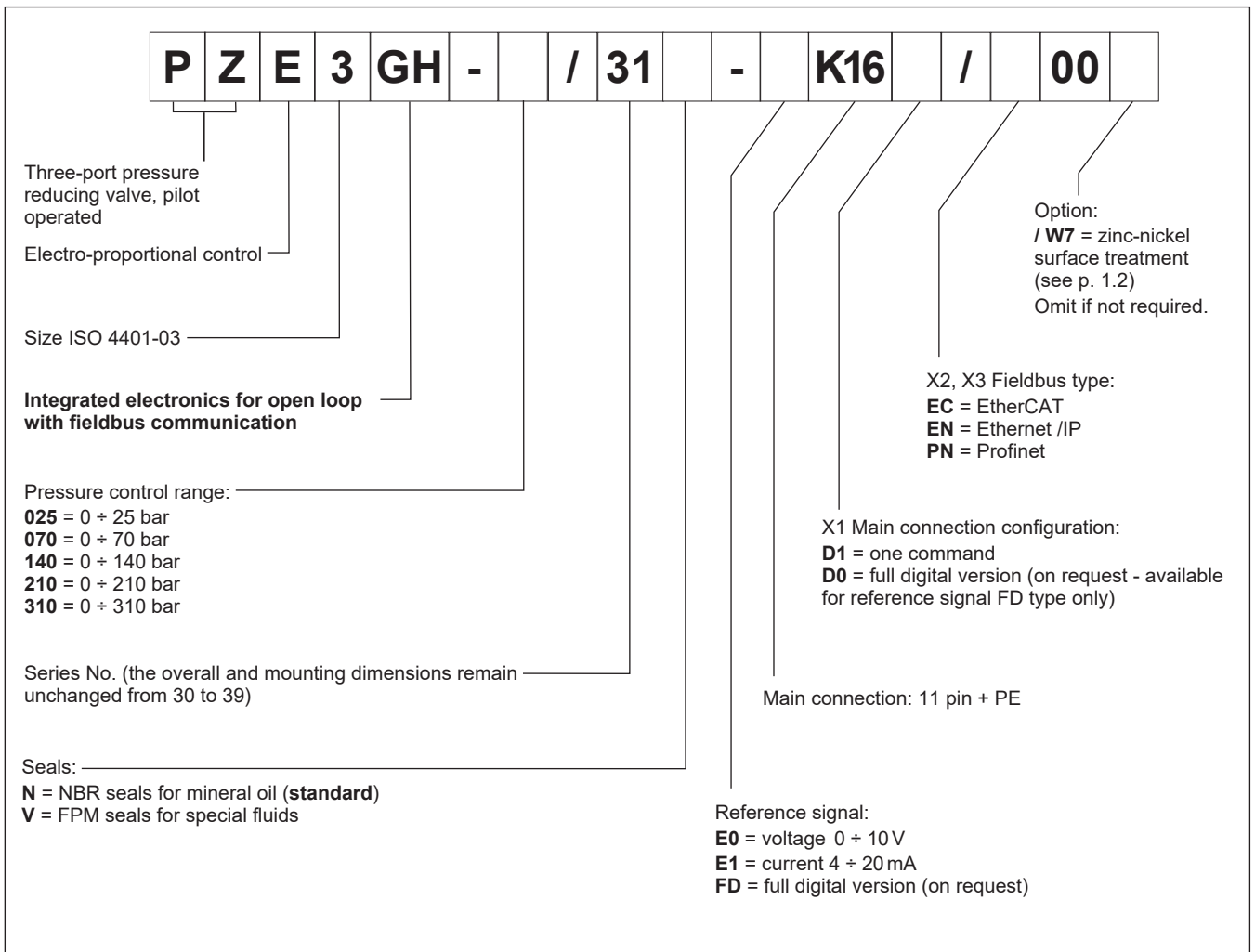

2 - ELECTRONICS COMMON DATA

Duty cycle		100% (continuous operation)
Protection class according to EN 60529		IP65 / IP67 (NOTE)
Supply voltage	V DC	24 (from 19 to 30 VDC), ripple max 3 Vpp
Power consumption	VA	25
Maximum solenoid current	A	1.88
Fuse protection, external	A	2A time lag
Managed breakdowns		Overload and electronics overheating, cable breakdown, supply voltage failures
Electromagnetic compatibility (EMC) emissions EN 61000-6-4, immunity EN 61000-6-2		According to 2014/30/EU standards

NOTE: The IP degree is guaranteed only with mating connector of equivalent IP degree, installed and tightened correctly. Moreover, on the GH versions it is necessary to protect any unused connections with caps.

3 - PZE3G - STANDARD ELECTRONICS

3.1 - Electrical characteristics

Command signal:	voltage (E0) current (E1)	V DC mA	0 ÷ 10 (impedance Ri > 11 kOhm) 4 ÷ 20 (impedance Ri = 58 Ohm)
Monitor signal (current to solenoid):	voltage (E0) current (E1)	V DC mA	0 ÷ 10 (impedance Ro > 1 kOhm) 4 ÷ 20 (impedance Ro = 500 Ohm)
Communication for diagnostic			LIN-bus Interface (by means of the optional kit)
Connection			6 pin + PE (MIL-C-5015-G - DIN EN 175201-804)

3.2 - On-board electronics diagrams

VERSION A - External Enable

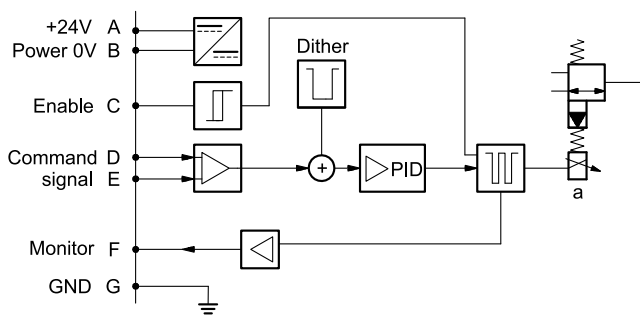

VERSION B - Internal Enable

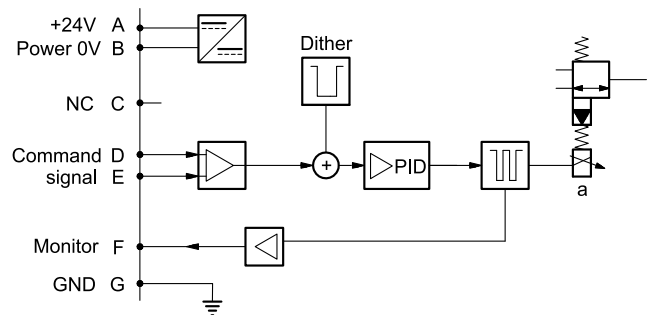

VERSION C - 0V Monitor

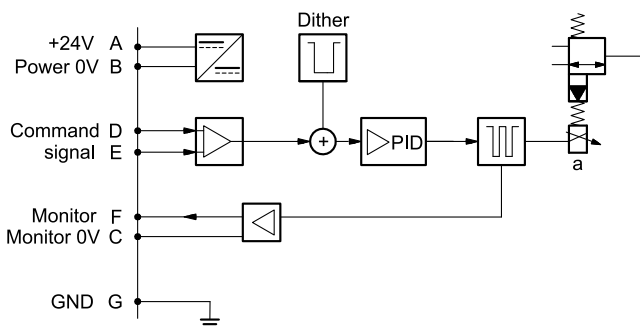

3.3 - Versions with voltage command (E0)

The reference signal is between $0 \div 10V$. The monitor feature of versions B and C becomes available with a delay of 0.5 sec from the power-on of the card.

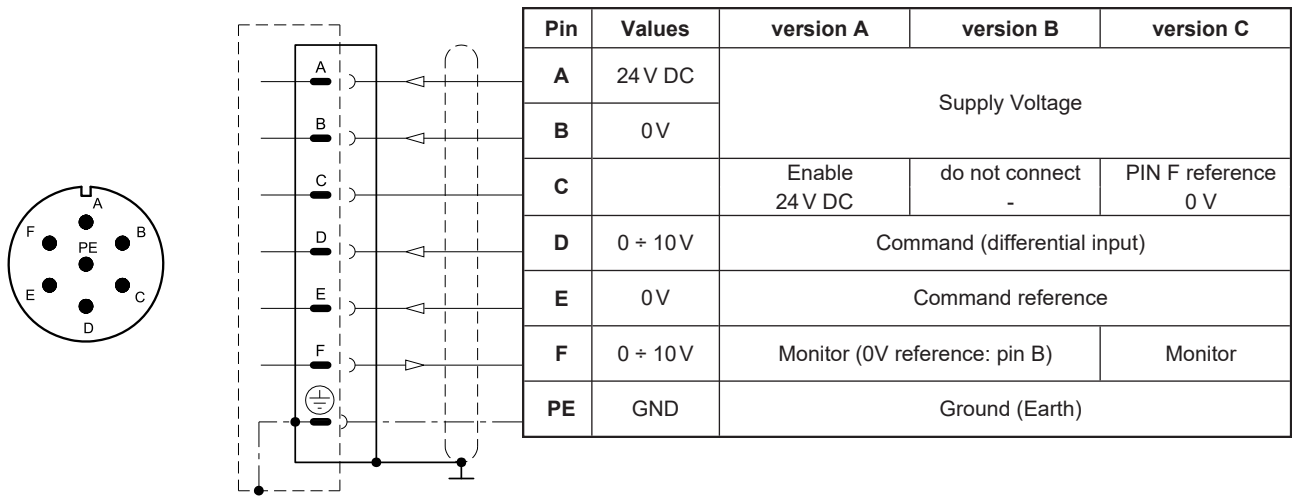
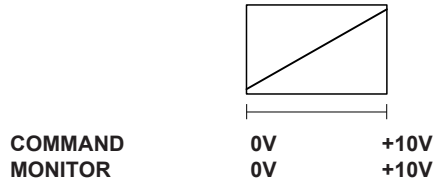

3.4 - Version with current command (E1)

The reference signal is supplied in current $4 \div 20$ mA. If the current for command is lower the card shows a breakdown cable error. To reset the error is sufficient to restore the signal.

The monitor feature of versions B and C becomes available with a delay of 0.5 sec from the power-on of the card.

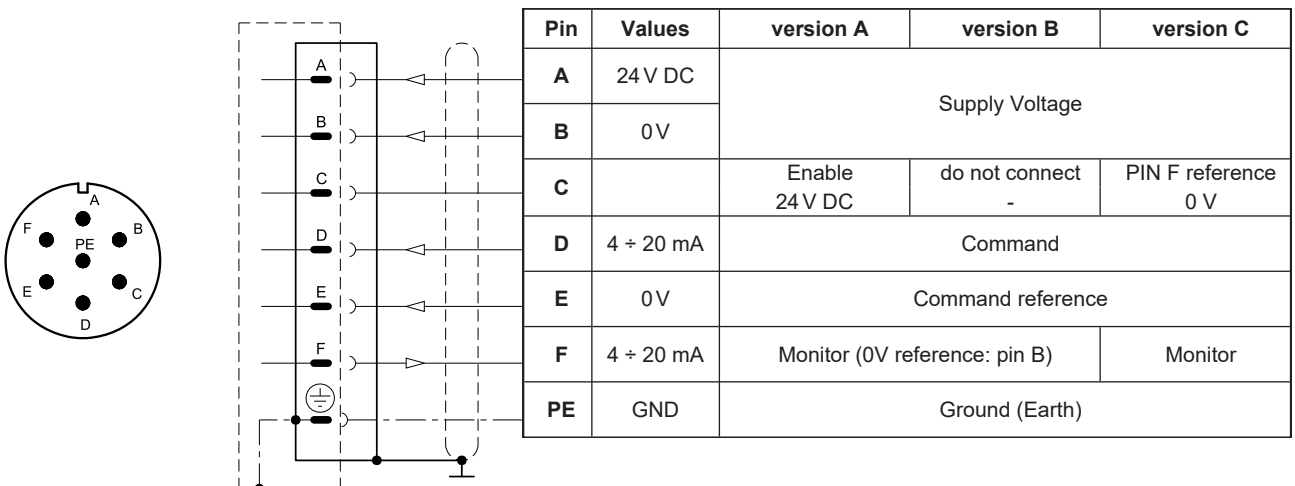
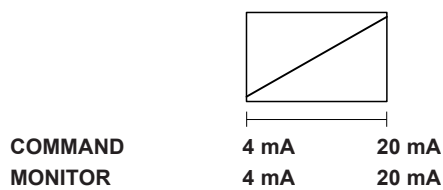

4 - PZE3GL - COMPACT ELECTRONICS

In IO-Link networks, the length of the connecting cables is limited to 20 metres. In CA versions, pin 3 and pin 5 are galvanic isolated up to 100 V to avoid earth loops.

4.1 - Electrical characteristics

Command signal: voltage (E0) current (E1)	V DC mA	0 ÷ 10 (impedance Ri > 11 kOhm) 4 ÷ 20 (impedance Ri = 58 Ohm)
Monitor signal (current to solenoid): voltage (E0) current (E1)	V DC mA	0 ÷ 5 (impedance Ro > 1 kOhm) 4 ÷ 20 (impedance Ro = 500 Ohm)
IO-Link communication (IOL): Data rate	kBaud	IO-Link Port Class B 38.4
Can Open communication (CA): Data rate	kbit	10 ÷ 1000
Data register (IOL and CA versions only)		card voltage supply, solenoid faults (shortcircuit, bad configuration), box temperature.
Connection		5-pin M12 code A (IEC 61076-2-101)

4.2 - Pin tables

'E0' connection



Pin	Values	Function
2	24 V DC	Supply voltage (solenoid and logic)
5	0V	
1	0 ÷ 10V	Command
3	0 V	Command reference
4	0 ÷ 5 V	Monitor (0V reference: pin 5)

'E1' connection



Pin	Values	Function
2	24 V DC	Supply voltage (solenoid and logic)
5	0V	
1	4 ÷ 20 mA	Command
3	0V	Command reference
4	4 ÷ 20 mA	Monitor (0V reference: pin 5)

'IOL' connection



Pin	Values	Function
2	2L+ 24 V DC	Solenoid supply voltage
5	2L- 0V (GND)	
1	1L+ +24 V DC	Logic and IO-Link supply voltage
3	1L- 0V (GND)	
4	C/Q	IO-Link Communication

NOTE: Pin 3 and pin 5 are linked with each other in the valve electronics. The reference potentials 1L- and 2L- of the two supply voltages must also be linked with each other on the customer side.

'CA' connection



Pin	Values	Function
1	CAN_SH	Shield
2	24 V DC	Supply voltage
3	0V (GND)	
4	CAN_H	Bus line (high)
5	CAN_L	Bus line (low)

5 - PZE3GH - FIELDBUS ELECTRONICS

The 11+ PE pin connection allows separate supply voltage for electronics and solenoid.

Command - valve position schemes as for the standard electronics. Please refer to pictures in p. 3.3 and 3.4.

5.1 - Electrical characteristics

Command signal:	voltage (E0) current (E1) digital (FD)	V DC mA	0 ÷ 10 (impedance Ri > 11 kOhm) 4 ÷ 20 (impedance Ri = 58 Ohm) via fieldbus
Monitor signal (current to solenoid):	voltage (E0) current (E1)	V DC mA	0 ÷ 10 (impedance Ro > 1 kOhm) 4 ÷ 20 (impedance Ro = 500 Ohm)
Communication / diagnostic			via Bus register
Communication interface standards			IEC 61158
Communication physical layer			fast ethernet, insulated 100 Base TX
Power connection			11 pin + PE (DIN 43651)

5.2 - X1 Main connection pin table

D1: one command

Pin	Values	Function
1	24 V DC	Main supply voltage
2	0 V	
3	24 V DC	Enable
4	0 ÷ 10 V (E0) 4 ÷ 20 (E1)	Command
5	0 V	Command reference signal
6	0 ÷ 10 V (E0) 4 ÷ 20 (E1)	Monitor (0V reference pin 10)
7	NC	do not connect
8	NC	do not connect
9	24 V DC	Logic and control supply
10	0 V	
11	24 V DC	Fault (0V DC) or normal working (24V DC) (0V reference pin 2)
12	GND	Ground (Earth)

D0: full digital

Pin	Values	Function
1	24 V DC	Main supply voltage
2	0 V	
3	24 V DC	Enable
4	NC	do not connect
5	NC	do not connect
6	NC	do not connect
7	NC	do not connect
8	NC	do not connect
9	24 V DC	Logic and control supply
10	0 V	
11	24 V DC	Fault (0V DC) or normal working (24V DC) (0V ref. pin 2)
12	GND	Ground (Earth)

5.3 - FIELDBUS connections

Please wire following guidelines provided by the related standards communication protocol. Any connections present and not used must be protected with special caps so as not to nullify the protection against atmospheric agents.

X2 (IN) connection: M12 D 4 pin female



Pin	Values	Function
1	TX+	Transmitter
2	RX+	Receiver
3	TX-	Transmitter
4	RX-	Receiver
HOUSING	shield	

X3 (OUT) connection: M12 D 4 pin female



Pin	Values	Function
1	TX+	Transmitter
2	RX+	Receiver
3	TX-	Transmitter
4	RX-	Receiver
HOUSING	shield	

NOTE: Shield connection on connector housing is recommended.

6 - CHARACTERISTIC CURVES

(measured with viscosity of 36 cSt at 50°C)

Typical control characteristics, according to the reference signal for available pressure control ranges. Characteristic curves measured without backpressure in T, with linearity compensation set by the onboard electronics.

PRESSURE CONTROL $p = f(I)$

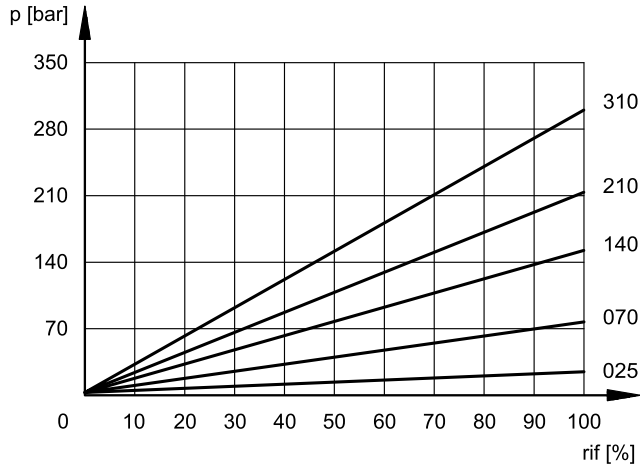

SET PRESSURE $p_{max} = f(Q)$

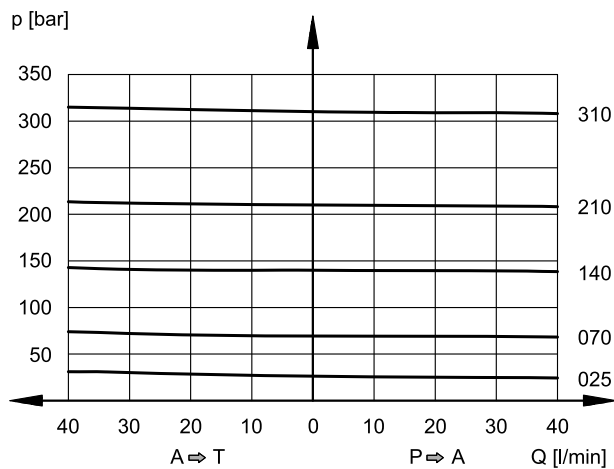

MIN. CONTROLLED PRESSURE $p_{min} = f(Q)$

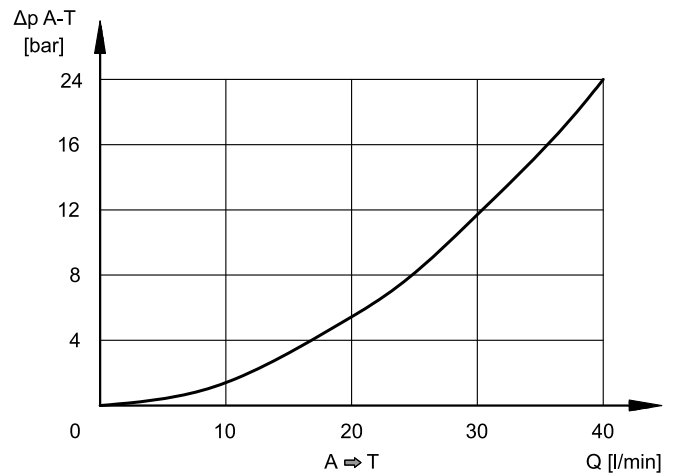

Pressure drops A → T vs. flow, without backpressure in T port and reference signal = 0 %

7 - RESPONSE TIMES

(obtained with mineral oil with viscosity of 36 cSt at 50°C)

Step response is the time taken for the valve to reach 90% of the set pressure value following a step change of reference signal.

The response time is affected both by the flow rate and the oil volume in the pipework.

REFERENCE SIGNAL STEP	0 → 100%	100 → 0%
Step response [ms]	80	80

8 - PZE3G - OVERALL AND MOUNTING DIMENSIONS

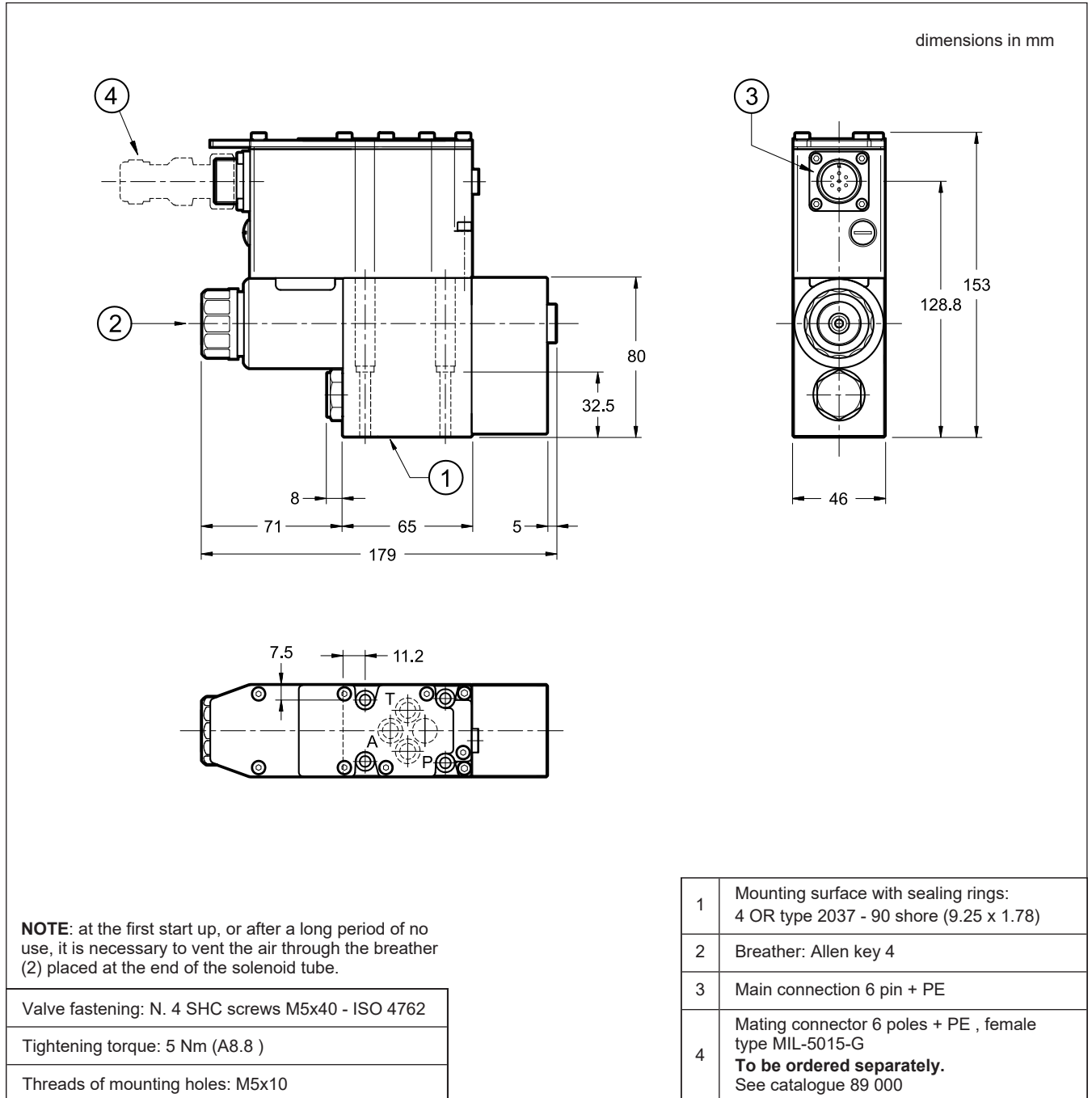

9 - PZE3GL - OVERALL AND MOUNTING DIMENSIONS

dimensions in mm

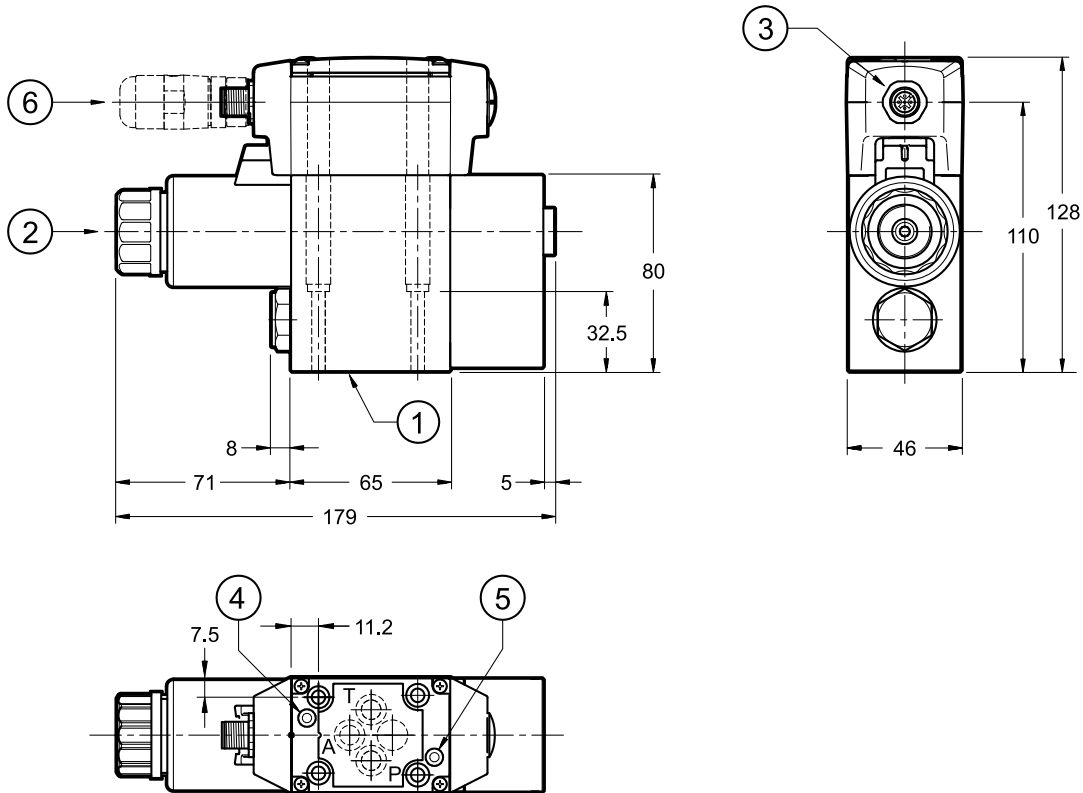

NOTE: at the first start up, or after a long period of no use, it is necessary to vent the air through the breather (2) placed at the end of the solenoid tube.

Valve fastening: N. 4 SHC screws M5x40 - ISO 4762

Tightening torque: 5 Nm (A8.8)

Threads of mounting holes: M5x10

1	Mounting surface with sealing rings: N. 4 OR type 2037 (9.25x1.78) 90 Shore
2	Breather: Allen key 4
3	Connection M12 A 5 pin
4	L1 LED
5	L2 LED
6	Mating connector M12 5 poles - code A, female To be ordered separately. See catalogue 89 000

10 - PZE3GH - OVERALL AND MOUNTING DIMENSIONS

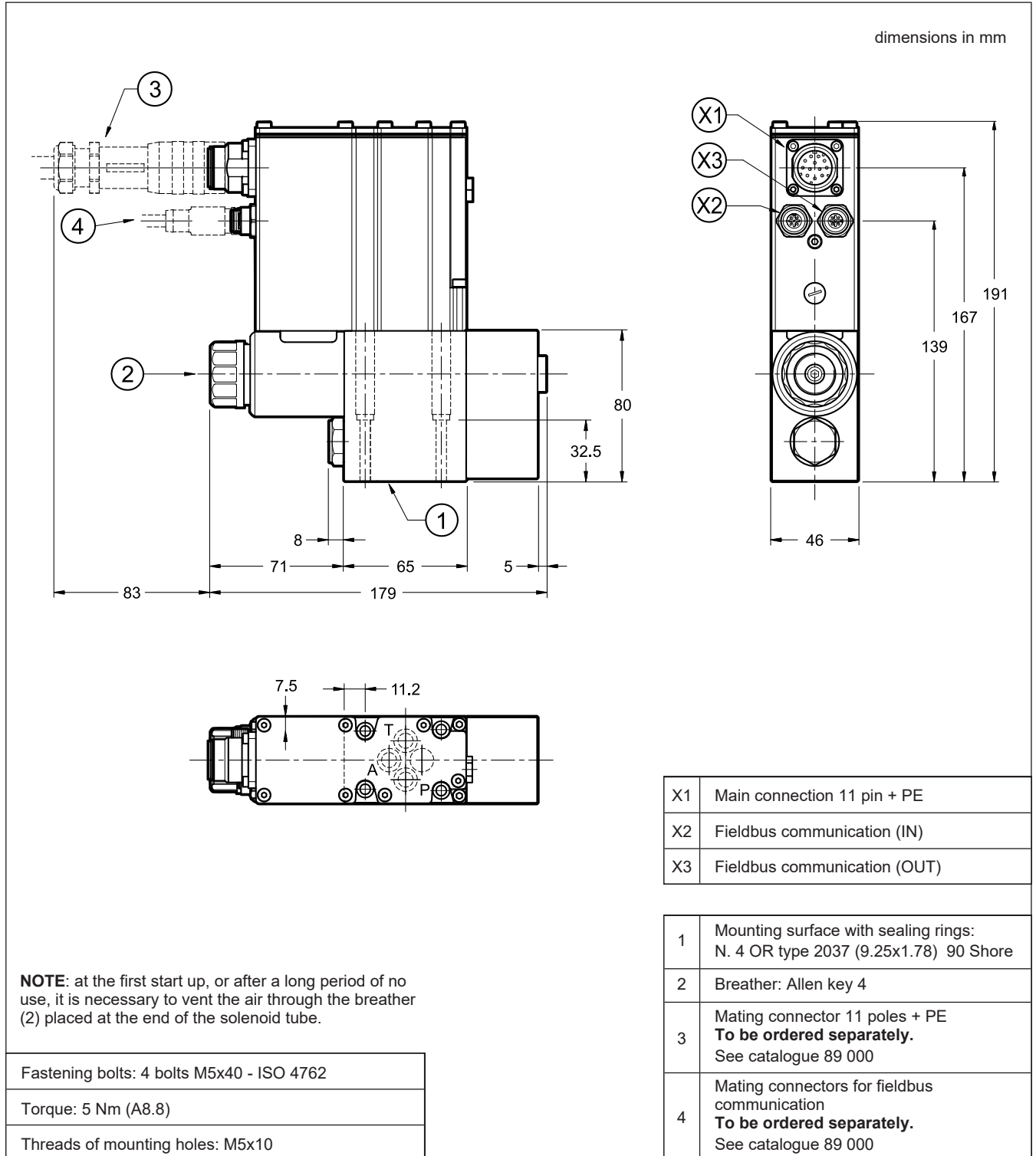

11 - HYDRAULIC FLUIDS

Use mineral oil-based hydraulic fluids HL or HM type, according to ISO 6743-4. For these fluids, use NBR seals. For fluids HFDR type (phosphate esters) use FPM seals (code V). For the use of other kinds of fluid such as HFA, HFB, HFC, please consult our technical department.

Using fluids at temperatures higher than 80 °C causes a faster degradation of the fluid and of the seals characteristics. The fluid must be preserved in its physical and chemical characteristics.

12 - INSTALLATION

We recommend to install the valves either in horizontal position, or vertical position with the solenoid downward. If the valve is installed in vertical position and with the solenoid upward, you must consider possible variations of the minimum controlled pressure, if compared to what is indicated in section 6.

Ensure that there is no air in the hydraulic circuit. In particular applications, can be necessary to vent the air entrapped in the solenoid tube, by using the appropriate drain screw in the solenoid tube. So, ensure the solenoid tube is always filled with oil. When finished, make sure you have screwed the screw back in correctly.

Connect the valve T port directly to the tank. Add any backpressure value detected in the T line to the controlled pressure value. Maximum admissible backpressure in the T line, under operational conditions, is 2 bar.

Valves are fixed by means of screws or tie rods on a flat surface with planarity and roughness equal to or better than those indicated in the relative symbols. If minimum values are not observed, fluid can easily leak between the valve and support surface.

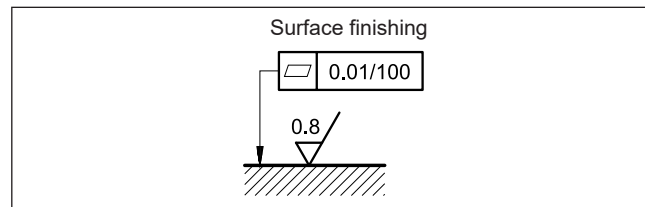

13 - ACCESSORIES

(to be ordered separately)

13.1 - Mating connectors

Mating connectors must be ordered separately. See catalogue 89 000.



For K11 and K16 versions we recommend the choice of a metal connector to avoid electromagnetic disturbances and to comply with EMC regulations on electromagnetic compatibility. If you opt for a plastic connector, make sure that it guarantees and maintains the IP and EMC protection characteristics of the valve.

13.2 - Mating connectors and caps for fieldbus communication

Duplomatic offers spare parts to be wired and also ready-to-use cord sets. Please refer to cat. 89 000.

13.3 - Connection cable

The optimal wiring provides for 7 isolated conductors, with separate screen for the signal wires (command, monitor) and an overall screen.

Cross section for power supply:

- up to 20 m cable length : 1,0 mm²
- up to 40 m cable length : 1,5 mm² (IO-Link excluded)

Cross section for signals (command, monitor):

- 0,50 mm²

13.4 - Kit for start-up LINPC-USB

Device for service start-up and diagnostic. See catalogue 89 850.

14 - SUBPLATES

(see catalogue 51 000)

PMMD-AI3G with ports on rear
PMMD-AL3G with side ports
Ports dimensions P, T, A, B: 3/8" BSP thread