



EHU
ECORICH
HYBRID HYDRAULIC
POWER UNIT

SERIES 40

TANK CAPACITY
45 litres

MOTOR PUMP FLOW RATE
up to 28.5 l/min

DESCRIPTION

EHU****-40-YC-QU-D1

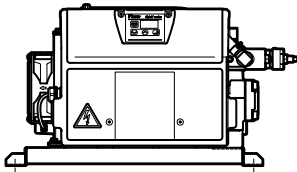

EHU****-40-YC-Q045-D1

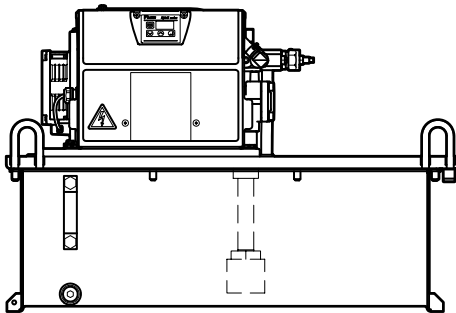

EHU****-40-YC-Q045M3-D1

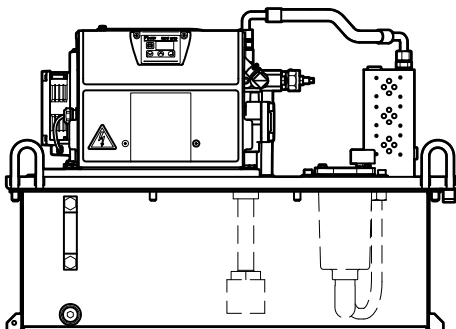

The ECORICH hybrid units are designed and manufactured by Daikin Industries LTD.

They merge the hydraulics technology with an interior permanent magnet synchronous motor.

The result is a compact power unit that achieves high torque and maximum efficiency while suppressing heat and noise generation. Energy consumption is reduced significantly.

The high efficiency of the motor-pump ensures that oil heating is minimal. This advantages the machine tool on which the ECORICH is installed in terms of oil and heat-sensitive parts life, and less heat dissipation in the surrounding ambient.

The power unit is designed for 3-phase AC 380 to 460V 50/60 Hz.

ECORICH hybrid units are available in three versions:

- EHU3007 pressure up to 70 bar, flow rate up to 28.5 l/min
- EHU2008 pressure up to 80 bar, flow rate up to 20 l/min
- EHU1414 pressure up to 135 bar, flow rate up to 13.5 l/min

They are deliverable with:

- fixing frame, no tank
- 45 litre tank, equipped with suction filter, level switch and customizable plate.
- 45 litre tank equipped with suction filter, level switch, multi station manifold for ISO 4401-03 valves and return filter.



1 - IDENTIFICATION CODE

	EHU		- 40		- Y C		- Q		- D1
--	------------	--	-------------	--	--------------	--	------------	--	-------------

ECORICH HYBRID UNIT

3007 = max flow rate **28.5 l/min**,
max operating pressure **70 bar**

2008 = max flow rate **20 l/min**,
max operating pressure **80 bar**

1414 = max flow rate **13.5 l/min**,
max operating pressure **135 bar**

Series No. _____
(from 40 to 49 sizes and mounting dimensions remain unchanged)

With oil cooler

Tank:
U = without tank
045 = tank 45 l
045M3 = tank 45 l with manifold station and return filter

With BSPP adapter.

With RS422/RS485 communication port (selectable by jumper)

3-phase AC power supply
380...460 V 50/60 Hz
without transformer

2 - SPECIFICATIONS

		EHU3007-40-YC		EHU2008-40-YC		EHU1414-40-YC	
		-QU	-Q045	-QU	-Q045	-QU	-Q045
Maximum operating pressure	bar	70				135	
Operating pressure range	bar	15 ÷ 70		15 ÷ 80		15 ÷ 135	
Operating flow range	l/min	3.5 ÷ 28.5		2.5 ÷ 20		1.8 ÷ 13.5	
Tank capacity	l	-	45	-	45	-	45
Oscillating volume	l	-	18	-	18	-	18
Supply voltage permissible voltage fluctuation		3-phase AC 380...460 V 50/60 Hz ±10%					
Nominal motor power	kW	1.5					
Rated current	A	7					
No-fuse breaker capacity	A	10					
Return flow filter rating (NOTE)	µm	-	25	-	25	-	25
Filling level monitoring shut off	l	-	25	-	25	-	25
Input signal, external		3 channels, photo coupler insulation, DC 24 V (maximum of DC 27 V), 5 mA / channel					
Digital output signal, external		1 channel, photo coupler insulation, open collector output, DC 24 V, 50 mA maximum / channel					
Contact output signal, external		1 channel, relay output, contact capacity: DC 30 V, 1 A (resistance load), 1 common contact					
Ambient temperature range	°C	0 to +40					
Fluid temperature range in the tank	°C	0 to +60 (recommended +15 to +50)					
Fluid contamination degree		within ISO 4406 class 20/18/15 (below 70 bar: within ISO 4406 class 21/19/16)					
Viscosity		Viscosity grade: ISO VG32 to 68 • Viscosity range: 15 to 400 mm ² /s					
Operating ambient humidity	RH	< 85%, without condensation					
Protection class		IP44					
Installation		altitude max 1000 mt , indoor, fixed on a flat surface without vibrations.					
Noise level range (distance: 1 m)		58 ÷ 70 dB					
Mass:	kg						
EHU*- QU		22	-	22	-	24	-
EHU*- Q045		-	58	-	58	-	60
EHU*- Q045M3		-	69	-	69	-	71

NOTE 2: Only for EHU*-Q045M3.

3 - CHARACTERISTICS

Values obtained and rated for ambient temperature $\leq 40\text{ }^{\circ}\text{C}$ and fluid temperature $\leq 40\text{ }^{\circ}\text{C}$.

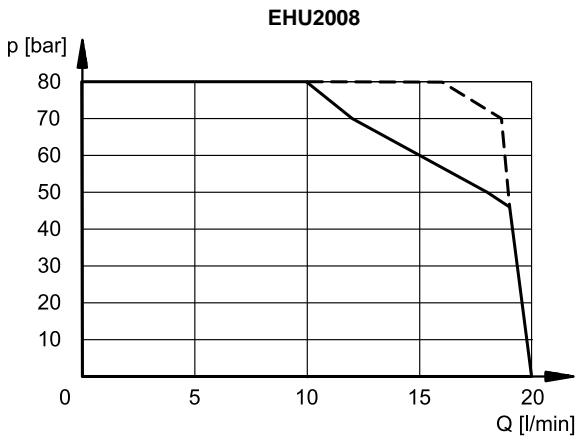
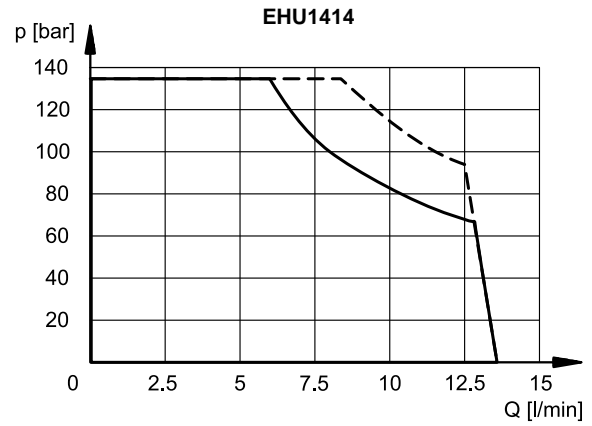
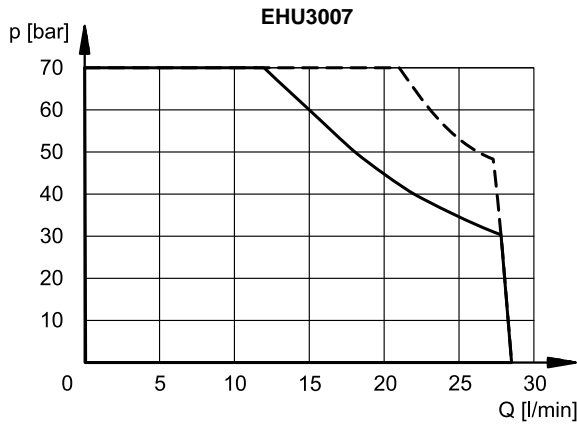

— Continuous running duty (S1)
 - - - Intermittent periodic duty with overload (S2 30 min)

4 - CIRCUIT DIAGRAMS

4.1 - Versions without tank

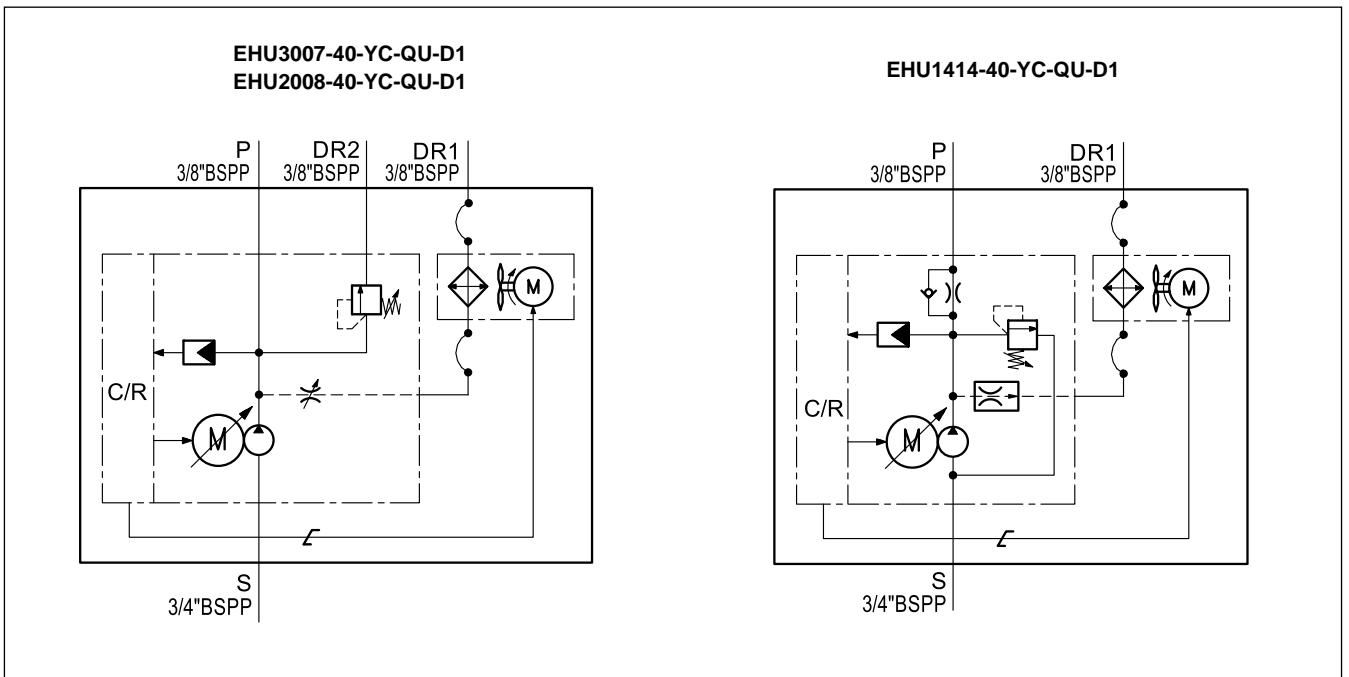

4.2 - EHU3007 and EHU2008 - Versions with tank

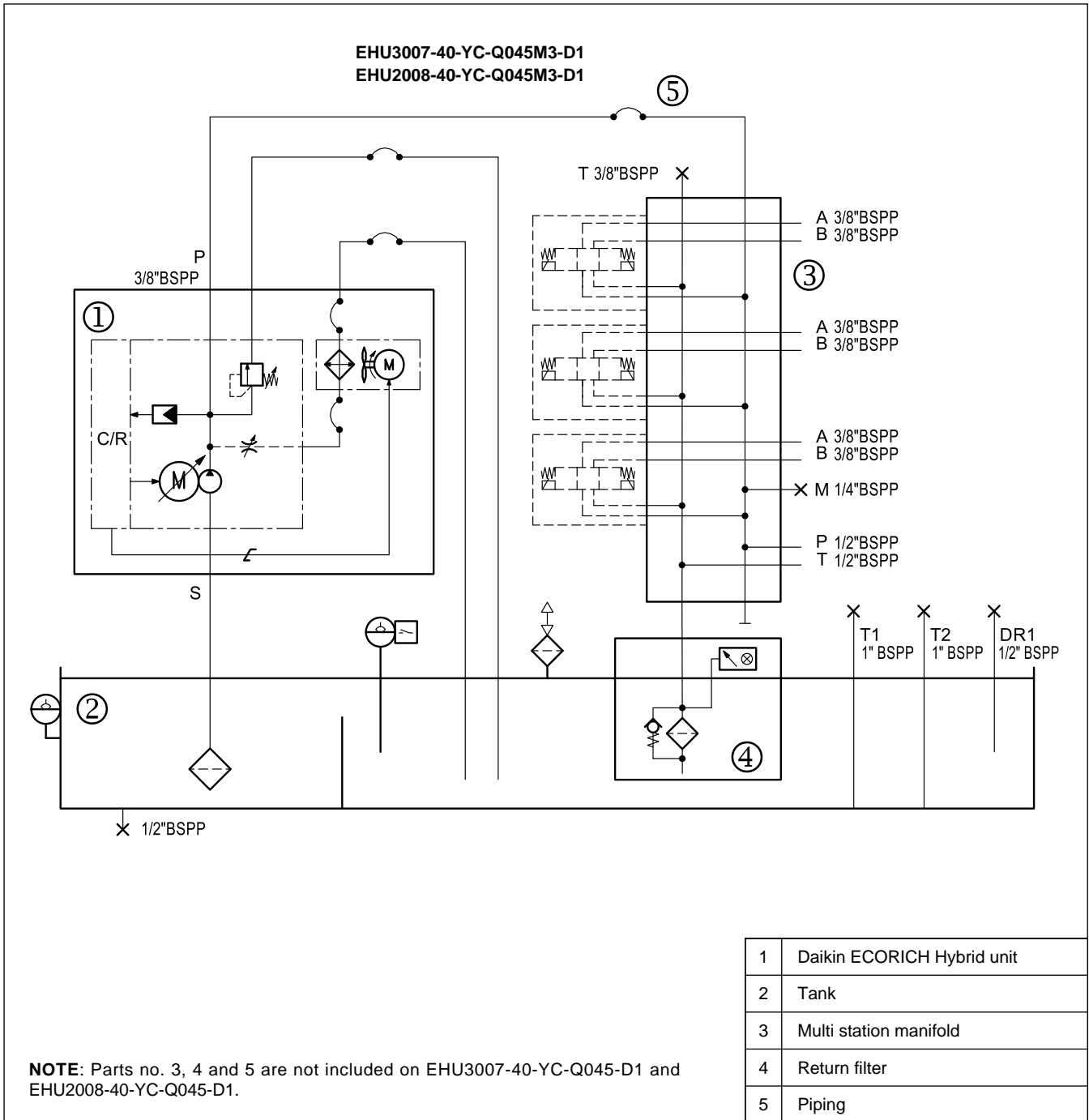

4.3 - EHU1414 - Versions with tank

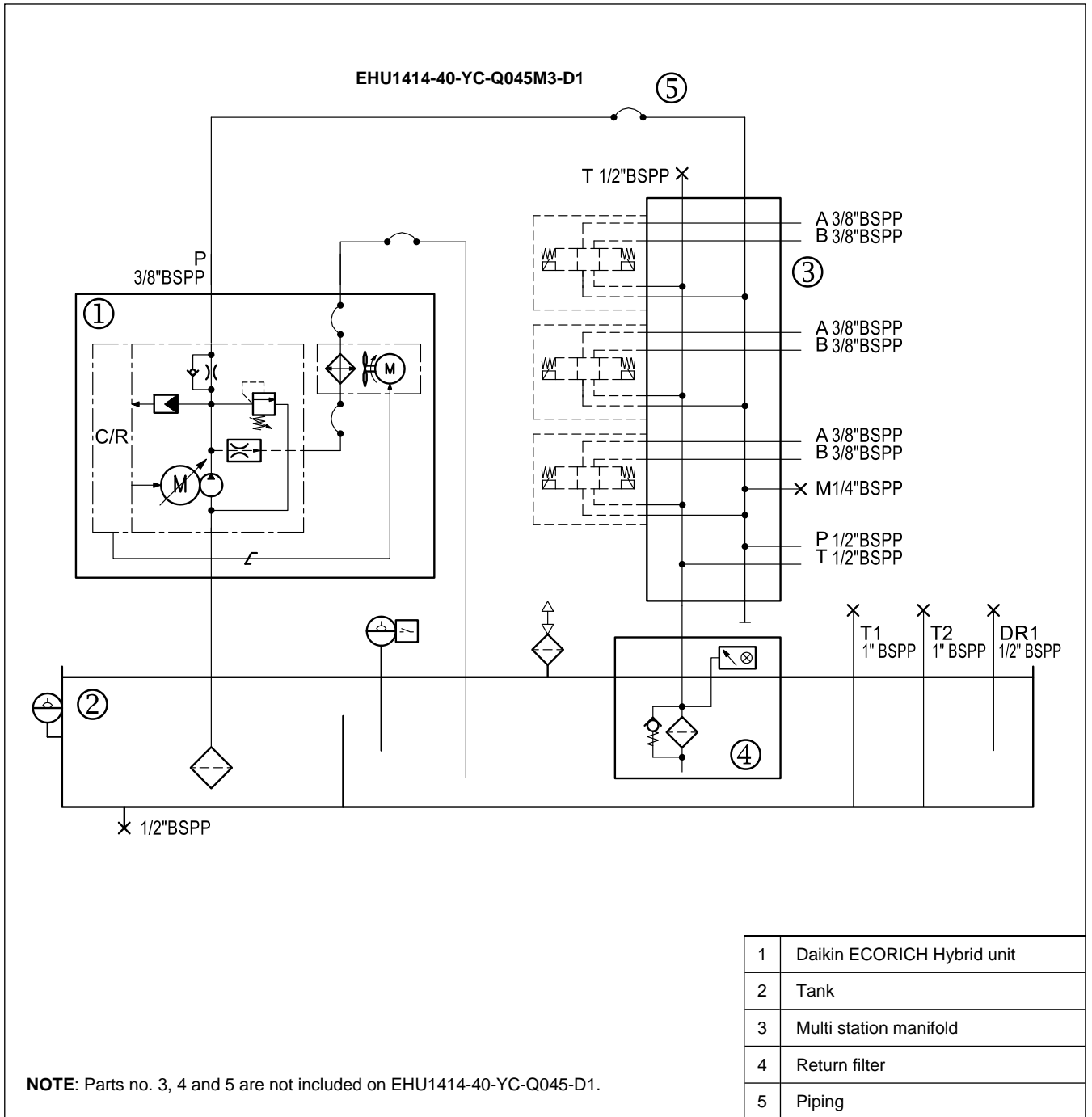

5 - EHU WITHOUT TANK (EHU****- 40-YC - QU-D1)

5.1 - Main parts

The main picture refers to the EHU3007 and EHU2008. Dimensions of EHU1414 that differ are reported in the table.

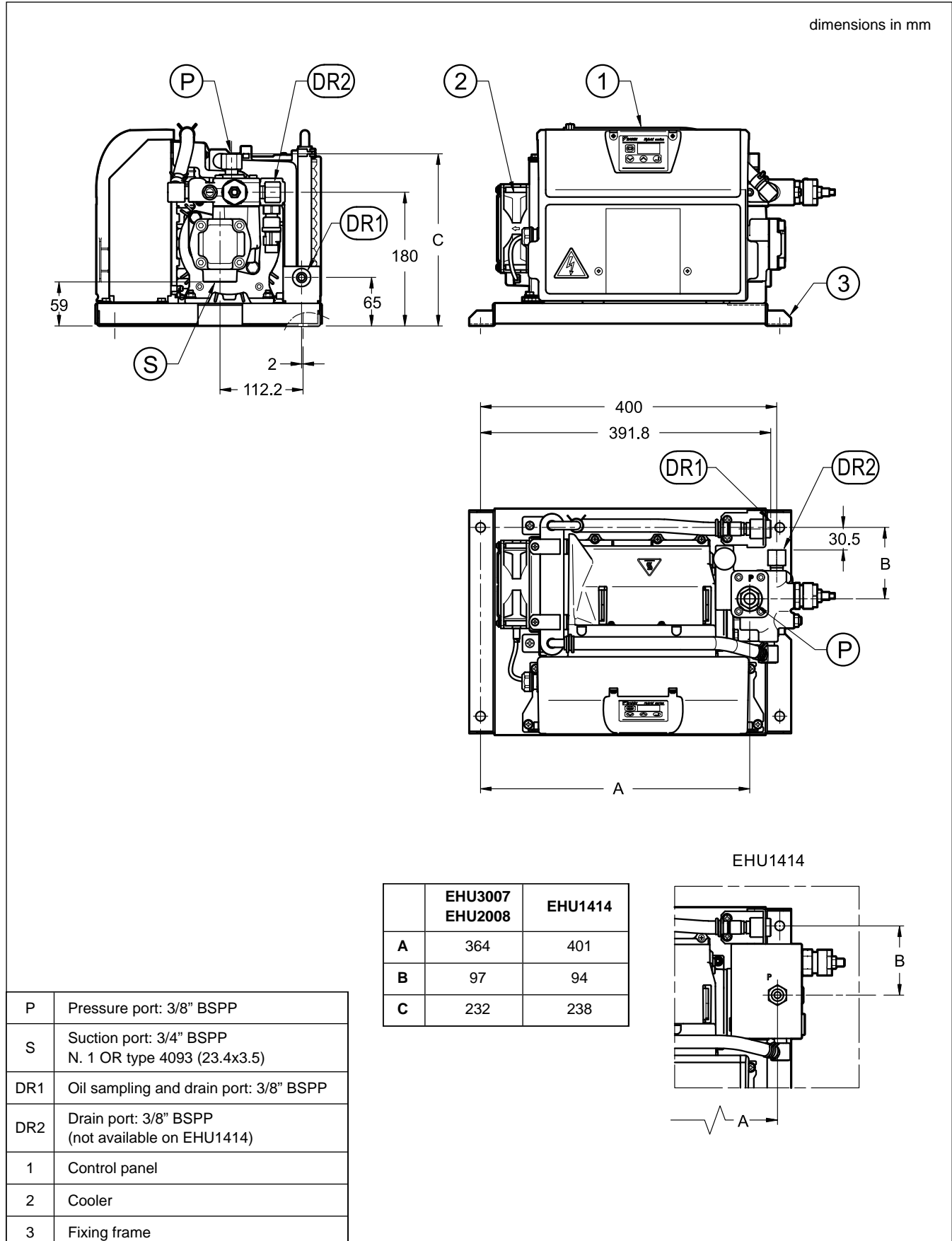

P	Pressure port: 3/8" BSPP
S	Suction port: 3/4" BSPP N. 1 OR type 4093 (23.4x3.5)
DR1	Oil sampling and drain port: 3/8" BSPP
DR2	Drain port: 3/8" BSPP (not available on EHU1414)
1	Control panel
2	Cooler
3	Fixing frame

5.2 - Overall and mounting dimensions

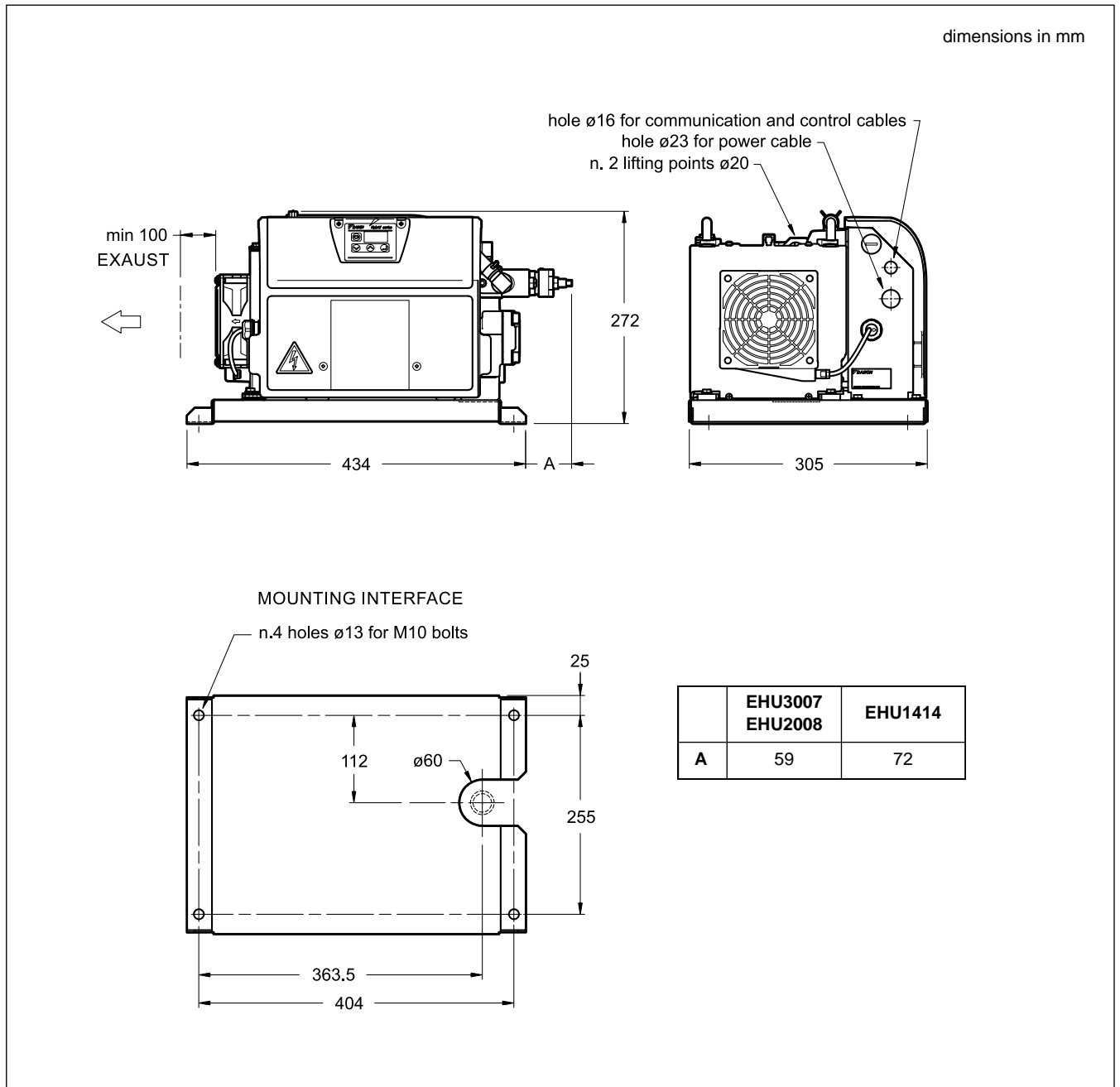

NOTE: The use of hose whip restraints devices both at pump side and at manifold side is strongly recommended to avoid the possible swip-off from the hose fitting during operation.

The EHU****-40-YC-Q045M3-D1 models are already equipped with these devices.

6 - EHU WITH TANK (EHU****-40-YC-Q045-D1)

6.1 - Main parts

The drawing is representative of all versions: EHU3007, EHU2008 and EHU1414.

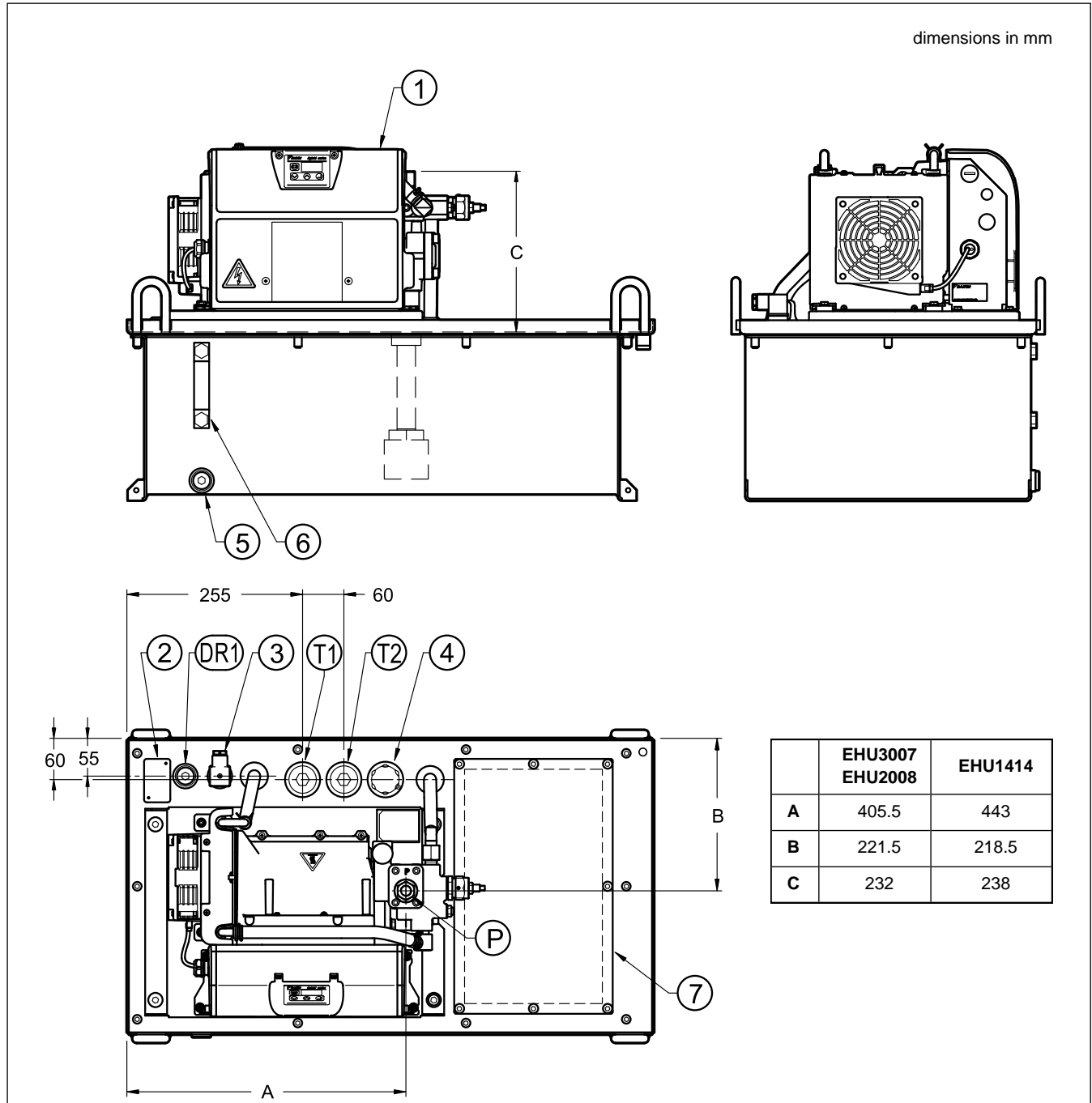

	EHU3007 EHU2008	EHU1414
A	405.5	443
B	221.5	218.5
C	232	238

P	Pressure port: 3/8" BSPP
T1	T1 ports for return / drain line: 1" BSPP delivered with plug
T2	T2 port: 1" BSPP delivered with plug
DR1	DR1 Drain port: 1/2" BSPP delivered with plug
1	EHU hybrid unit
2	Label identification

3	Level switch
4	Oil filler port with air breather
5	Oil sampling and tank drain port
6	Oil level indicator: upper 48 L; lower 30 L
7	Blind plate, customizable area 200x340 mm

6.2 - Overall and mounting dimensions

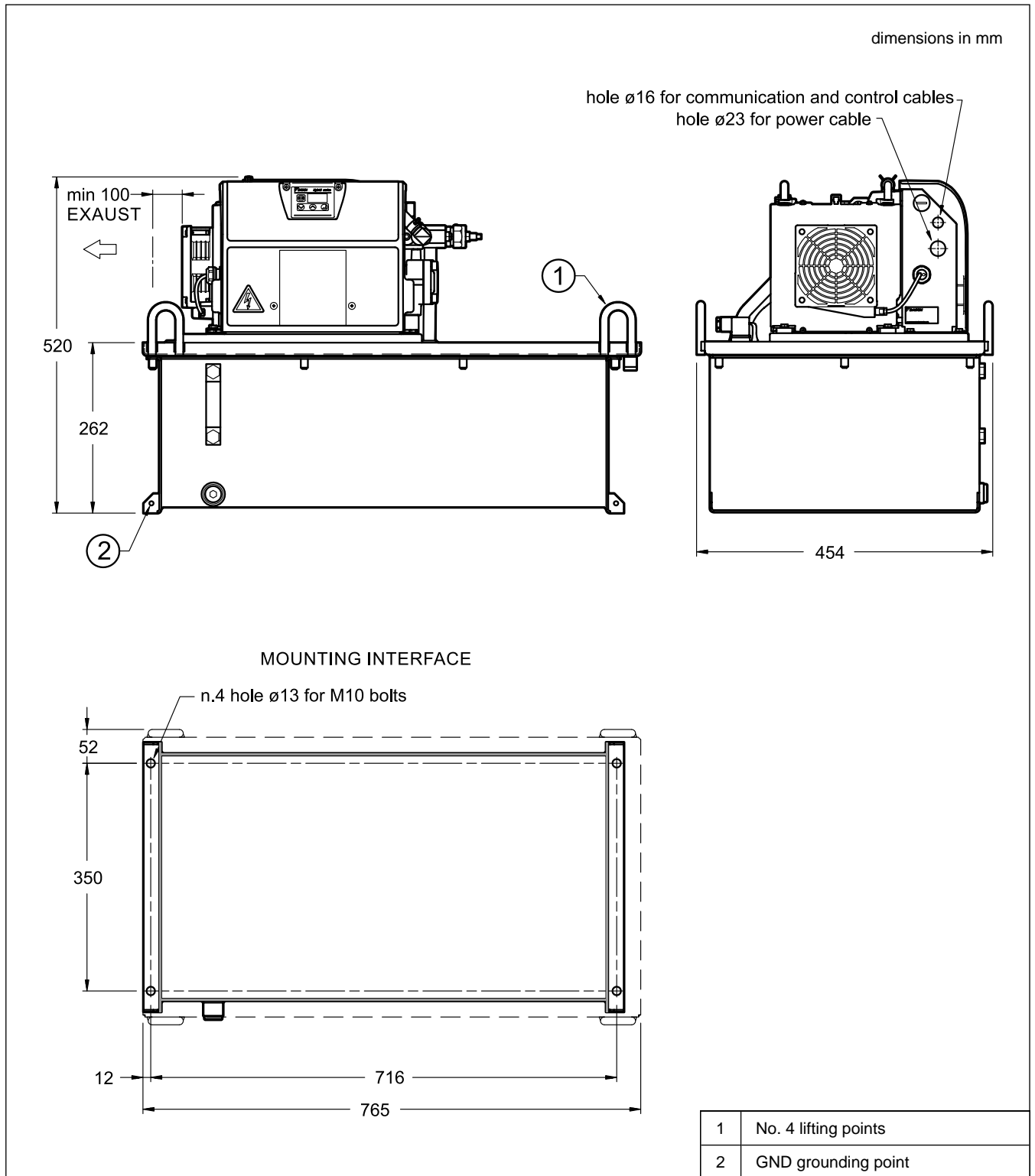

NOTE: The use of hose whip restraints devices both at pump side and at manifold side is strongly recommended to avoid the possible swip-off from the hose fitting during operation.

The EHU****-40-YC-Q045M3-D1 models are already equipped with these devices.

7 - EHU WITH TANK, 3-STATION MANIFOLD AND RETURN FILTER (EHU****- 40-YC - Q045M3-D1)

7.1 - Main parts

The drawing is representative of all versions: EHU3007, EHU2008 and EHU1414.

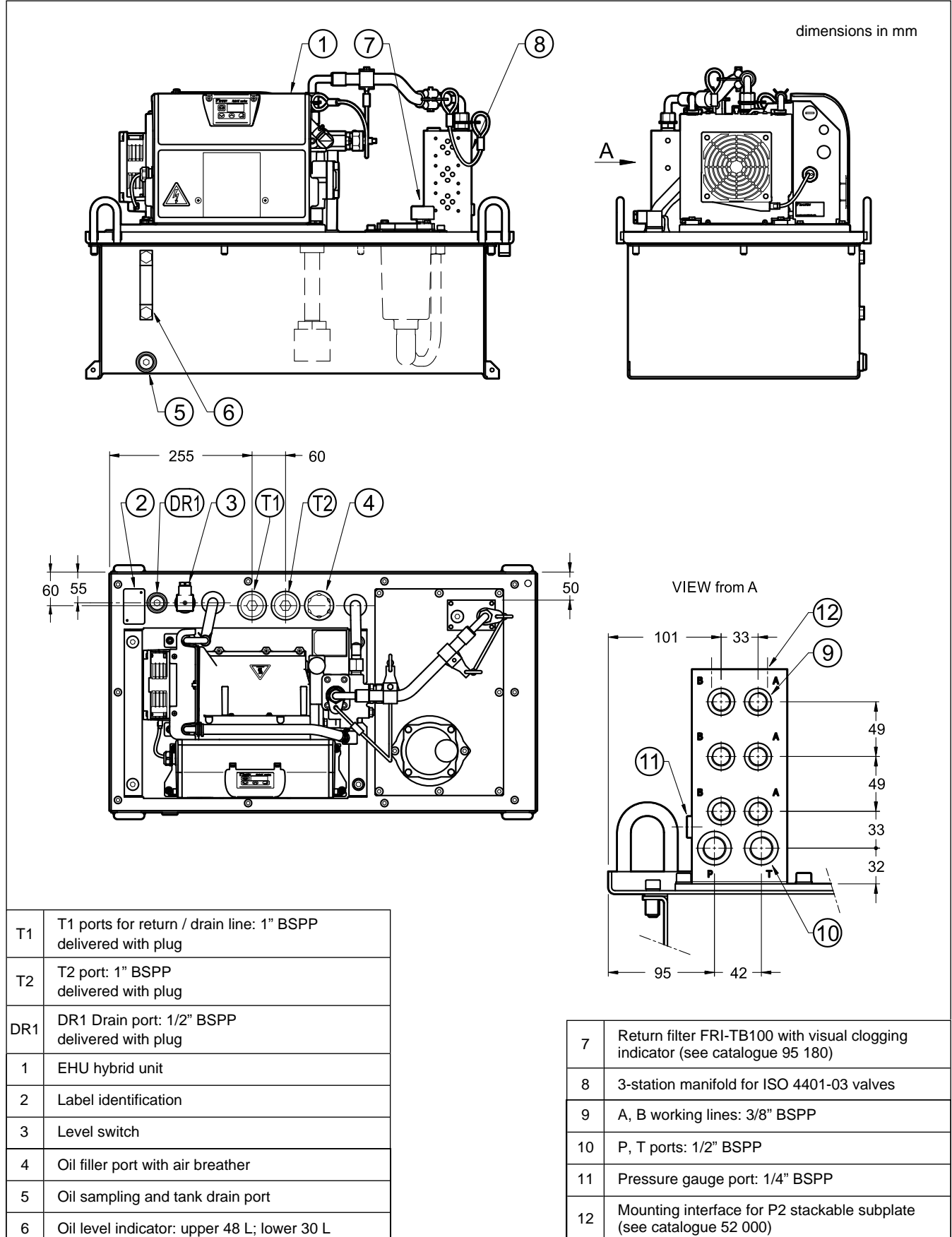

T1	T1 ports for return / drain line: 1" BSPP delivered with plug
T2	T2 port: 1" BSPP delivered with plug
DR1	DR1 Drain port: 1/2" BSPP delivered with plug
1	EHU hybrid unit
2	Label identification
3	Level switch
4	Oil filler port with air breather
5	Oil sampling and tank drain port
6	Oil level indicator: upper 48 L; lower 30 L

7	Return filter FRI-TB100 with visual clogging indicator (see catalogue 95 180)
8	3-station manifold for ISO 4401-03 valves
9	A, B working lines: 3/8" BSPP
10	P, T ports: 1/2" BSPP
11	Pressure gauge port: 1/4" BSPP
12	Mounting interface for P2 stackable subplate (see catalogue 52 000)

7.2 - Overall and mounting dimensions

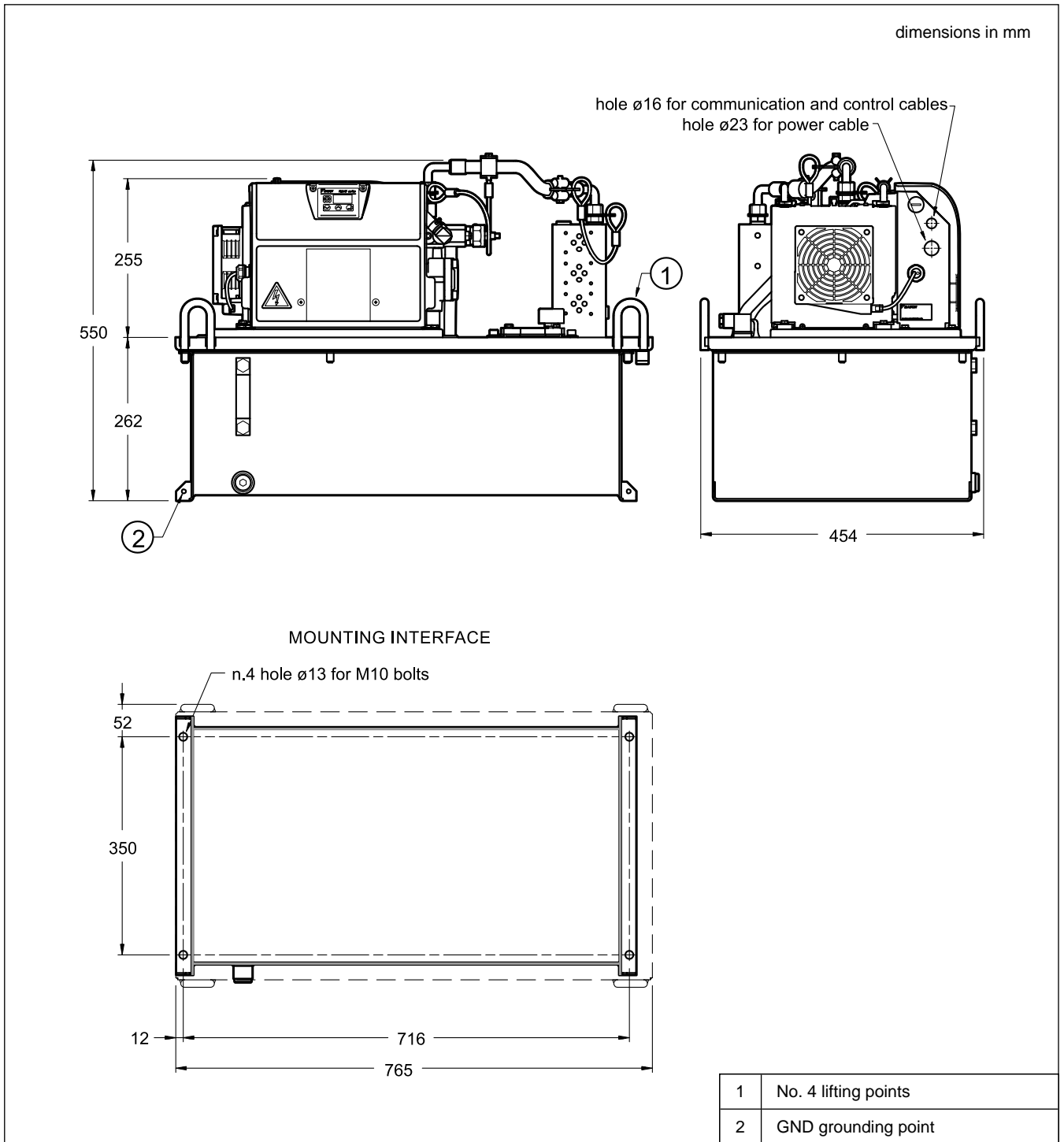

8 - WIRING

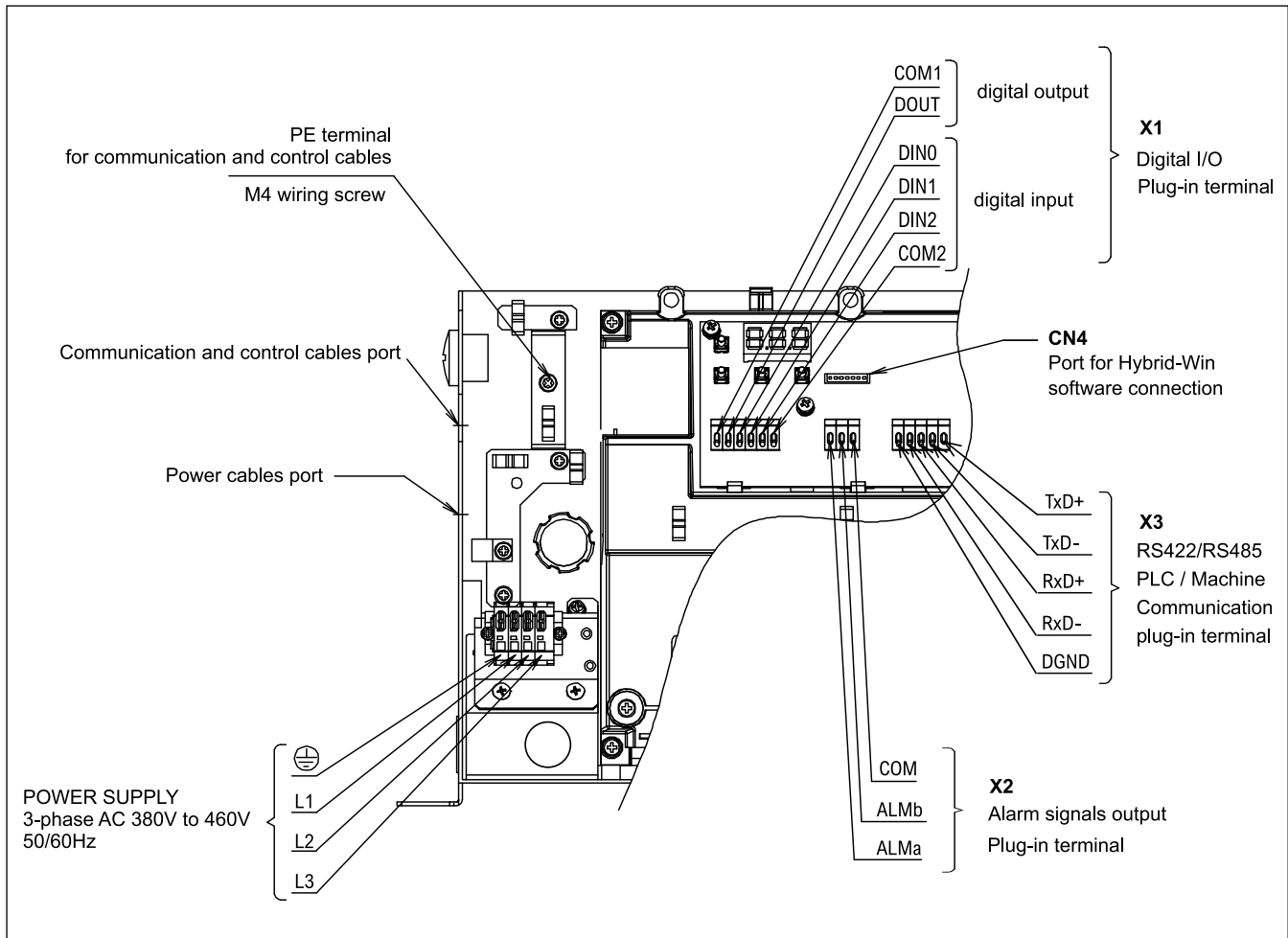

8.1 - EMC 2014/30/EU compliance

The EN 61800-3:2004 (Second environment / PDS Category "C3") requires the installation of a surge protection device and a noise filter between the breaker and the ECORICH hybrid unit on the power source line.

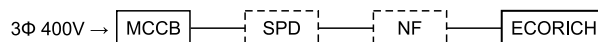

The assessment for the installation of these components is the responsibility of the machine manufacturer, as compliance with EMC regulations involves the entire machine on which the EHU unit will be installed. If EHU has to be in compliance with EMC 2014/30/EU as a standalone, noise filter and protection device are must have.

Surge protection device (SPD) and noise filters can be ordered separately. See point 12.

8.2 - Wiring notes

- Install a no-fuse breaker and a ground fault interrupter compliant with European Standard EN 60947-2 in the main power supply of ECORICH, to protect the electrical circuits against shorting and overcurrent, and to prevent electric shocks.
- Use straight type terminals for the power supply wiring.
- Use suitable electric cable in accordance with the power supply capacity. In addition, connect the cables correctly in accordance with the wiring guide.
- Provide a ground connection in compliance with the law in the relevant country. Connect the grounding wire directly with no breaker in the line.
- Avoid the entry of waste metal such as screws and wiring debris, or combustible matter such as wood waste or oil, inside the control unit.
- Use a commercial power supply for the power source. The use of an inverter power supply may cause burn damage to the unit.
- Before accessing the interior of the control unit, check that the unit's power supply has turned OFF **and then wait at least 5 minutes**.

8.3 - Cables

For the main power connection (L1, L2 and L3) use cables with 4-wires, with 1.5 mm² section.

For signals and for ModBUS communication to the PLC use shielded cables with section from 0.35 mm² to 0.5 mm².

9 - BLOCK DIAGRAM

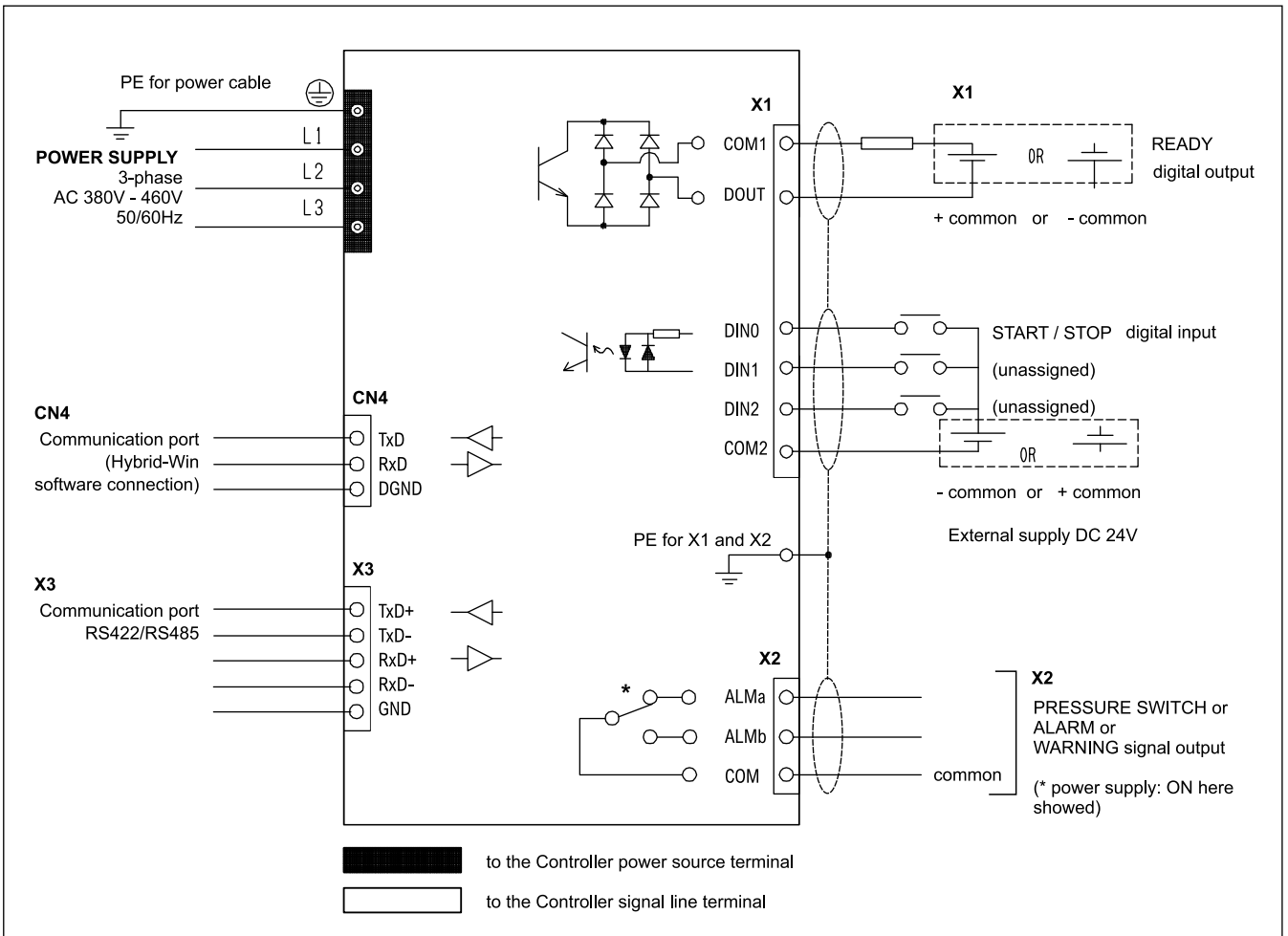

Digital I/O & alarm signals

		description		function / notes
X1	COM1	common digital output	24 V DC ($\pm 10\%$) I max 50 mA resistive	Can be either positive or negative
	DOUT	digital output		Ready to operate / motor operation signal. ON or OFF is selectable by parameter setting.
	COM2	common digital input	24 V DC ($\pm 10\%$) I max 5 mA resistive	Can be either positive or negative
	DIN0	digital input 0		Unit start / stop signal. Selectable by parameter setting.
	DIN1	digital input 1		reserved
	DIN2	digital input 2		reserved
X2	ALMa	alarm output A	switching 30 V DC 1A resistive (min load 24 V DC 10 mA approx)	When the power supply unit is switched ON, ALMa closes. (ALMb open). If an alarm (E**) or a warning (L70) has occurred; when the pressure switch is actuated, the ALMa contact is open (ALMb closed).
	ALMb	alarm output B		
	COM	common alarm output		

10 - INSTALLATION NOTES

10.1 - Installation and piping

- The unit is a stationary type. Fix it with bolts on a level location that is free of vibration.
- Keep obstacles that will obstruct air intake and emission at least 100 mm away from the end face of the unit. Install the unit at a location with good air flow so that heated air can be vented.

10.2 - Hydraulic fluid

- Use mineral-oil base hydraulic oil. Use of hydraulic oils other than mineral-oil based type (e.g., hydrous/synthetic) is prohibited.

10.3 - Other precautions

- If a failure occurs in the hydraulic unit, the system indicates an alarm and terminates. If a failure or malfunction of this unit is expected to cause death or pose a danger to human beings, adopt appropriate safety measures in the facilities.
- Turning the power supply ON/OFF frequently will significantly shorten the life of the controller. Use the start/stop digital inputs to start/stop this hydraulic unit. Leave an interval of at least 5 minutes between operation stops invoked by turning the power supply ON/OFF. Also, when starting and stopping the unit using the start/stop signals, leave an interval of at least 0.5 seconds between a stop command and restarting.
- It takes approximately 3 seconds for this hydraulic unit to start up after being powered ON. Depending on the piping conditions, the unit may take longer to increase the pressure to the pressure switch's preset level, resulting in pressure switch signal output. In this case, set the machine up so that it will not accept this alarm output during this period.

11 - DEVICE SETUP

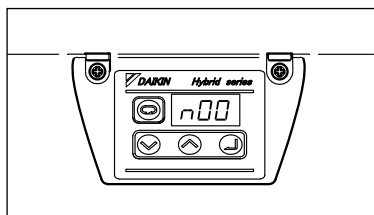

The ECORICH hybrid unit is configured by connecting the CN4 port located inside the unit control panel to a device with the Hybrid-win software installed. It is always possible to modify the parameters also by keys on the control panel.

The ECORICH unit communicates with the machine tool via Modbus-RTU protocol. The communication setting between them is done from the operation panel of the hydraulic unit.

11.1 - Hybrid-win software

The software allows to monitor the operating data in real time through a graphical interface; to read and set parameters, to monitor alarms and warnings history and to save and copy the parameter set.

The software is compliant with Microsoft Windows OS.

The connection between the ECORICH and the PC requires a cable connection kit, that can be ordered separately. See point 12.

The Hybrid-win software and the additional literature for the ECORICH unit can be easily downloaded from the Customer's page in the product section at www.hyd.daikin.com

11.2 - Parameters table

Please refer to the *Instruction Manual PIM00496 (English)* delivered with the product for a complete list of parameters and their settings.

12 - ACCESSORIES

These accessories are supplied separately and their assembly on the power unit is charged to the customer.

ordering code	description
3906500015	LS-B12-140/10-D24K1-SPDT Level switch SPDT 1/2" BSPP. (NOTE)
3906500012	TS-B12-170-60/10-D24K1-SPDT Temperature switch 1/2" BSPP - 24V DC switching temperature 60 °C.
3906500002	PM-SPD01 - Surge protection device for EHU#-40/SUT#-40
3906500001	PM-SNF12 - Noise filter for EHU#-40
3906500003	EHUPC/10 - Kit for Hybrid-Win software connection

NOTE: This part is already installed as standard on the power units with tank. Available as spare part.