



PRE*J*

PROPORTIONAL PRESSURE RELIEF VALVES, PILOT OPERATED, WITH PRESSURE FEEDBACK AND INTEGRATED ELECTRONICS

SUBPLATE MOUNTING

p max **350** bar
Q max (see table of performances)

OPERATING PRINCIPLE

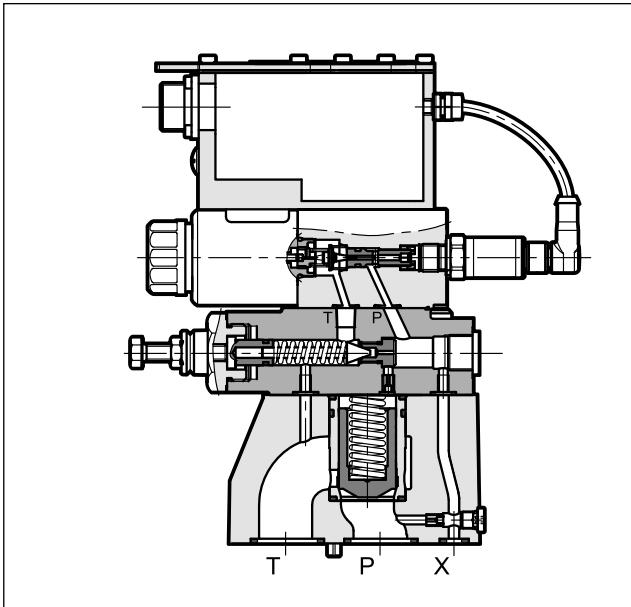

- PRE*J* valves are proportional pressure relief valves, pilot operated, with integrated electronics and pressure closed loop, with mounting interface in compliance with ISO 6264 standard.
- These valves are used to control hydraulic circuit pressure and enable the use of the full flow rate of the pump, even with settings approaching calibrated values.
- The two-stage design and wide passages ensure reduced pressure drops thereby improving the system energy performance.
- They are fitted with a manual pressure relief valve which is factory set to $\geq 15\%$ of the maximum value in the pressure control range.
- Valves are available with different types of electronics, with analogue or fieldbus interfaces.
- They are available in three sizes with flow rates up to 500 l/min and in four pressure control ranges up to 350 bar.
- The valves are easy to install. The driver directly manages digital settings.

PERFORMANCES

(obtained with mineral oil with viscosity of 36 cSt at 50 °C and p = 140 bar)

		PRE10J*	PRE25J*	PRE32J*
Maximum operating pressure	bar	350		
Maximum flow	l/min	200	400	500
Step response		see point 8		
Hysteresis	% of p nom	< 1%		
Repeatability	% of p nom	< $\pm 0,5\%$		
Electrical characteristic		see point 3		
Ambient temperature range	°C	-20 / +60		
Fluid temperature range	°C	-20 / +80		
Fluid viscosity range	cSt	10 ÷ 400		
Fluid contamination degree		According to ISO 4406:1999 class 18/16/13		
Recommended viscosity	cSt	25		
Mass	kg	5,5	6,3	8,5

HYDRAULIC SYMBOL

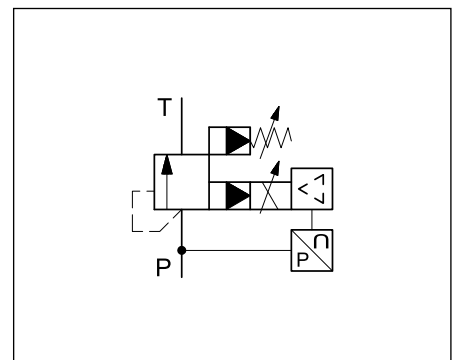

1 - IDENTIFICATION CODE

1.1 - Standard electronics

P	R	E	J	-	/	33	-	K11	
----------	----------	----------	----------	---	---	-----------	---	------------	--

Pilot operated pressure relief valve

Electro-proportional control

Size: _____
10 = ISO 6264-06
25 = ISO 6264-08
32 = ISO 6264-10

Integrated electronics for valves with pressure feedback

Pressure control range _____
140 = up to 140 bar **210** = up to 210 bar
350 = up to 350 bar

Series No. _____
 (the overall and mounting dimensions remain unchanged from 30 to 39)

Option:
/ W7 = Zinc-nickel surface treatment (see **NOTE**)
 Omit if not required

Pin C function:
A = external enable
B = internal enable
C = 0V monitor

Connection 6 pin + PE

Reference signal:
E0 = voltage 0 ÷ 10 V **E1** = current 4 ÷ 20 mA

Seals:
N = NBR seals for mineral oil (**standard**)
V = FPM seals for special fluids

1.2 - Detailed symbol

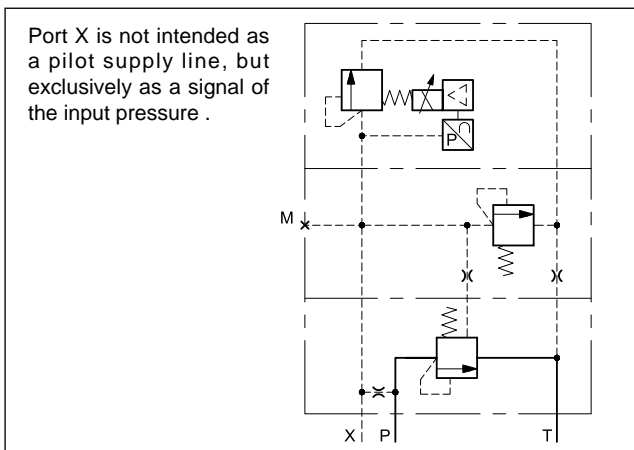

NOTE: The standard valve is supplied with surface treatment of phosphating black on the valve body.

The zinc-nickel finishing makes the valve suitable to ensure a salt spray resistance up to 240 hours (test operated according to EN ISO 9227 standards and test evaluation operated according to UNI EN ISO 10289 standards).

1.3 - Compact electronics

P	R	E	JL	-	/	-	K12	
----------	----------	----------	-----------	---	---	---	------------	--

Pilot operated pressure relief valve

Electro-proportional control

Size: _____
10 = ISO 6264-06
25 = ISO 6264-08
32 = ISO 6264-10

Integrated electronics for valves with pressure feedback - compact version

Pressure control range _____
140 = up to 140 bar
210 = up to 210 bar
350 = up to 350 bar

Series No. (the overall and mounting dimensions remain unchanged from 10 to 19):
10 = versions with E0, E1 and CA interfaces
11 = version with IOL interface

Option:
/ W7 = Zinc-nickel surface treatment (see **NOTE** point 1.1)
 Omit if not required

Connection 5 pin M12

Interfaces:
E0 = analogue, voltage 0 ÷ 10 V
E1 = analogue, current 4 ÷ 20 mA
IOL = IO-Link interface
CA = CAN Open

Seals:
N = NBR seals for mineral oil (**standard**)
V = FPM seals for special fluids

1.4 - Electronics with fieldbus communication

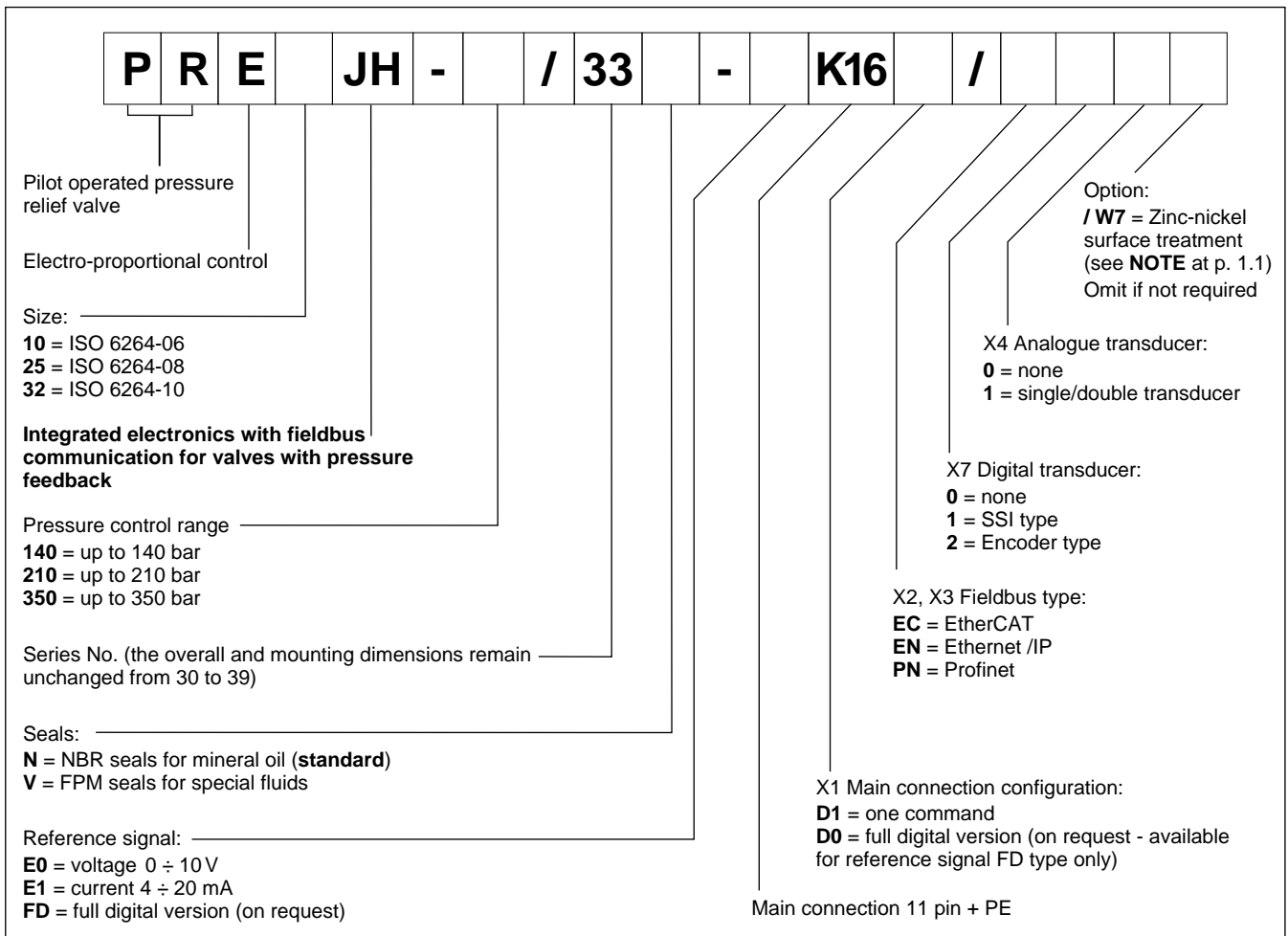

2 - COMPARISON AMONG INTEGRATED ELECTRONICS

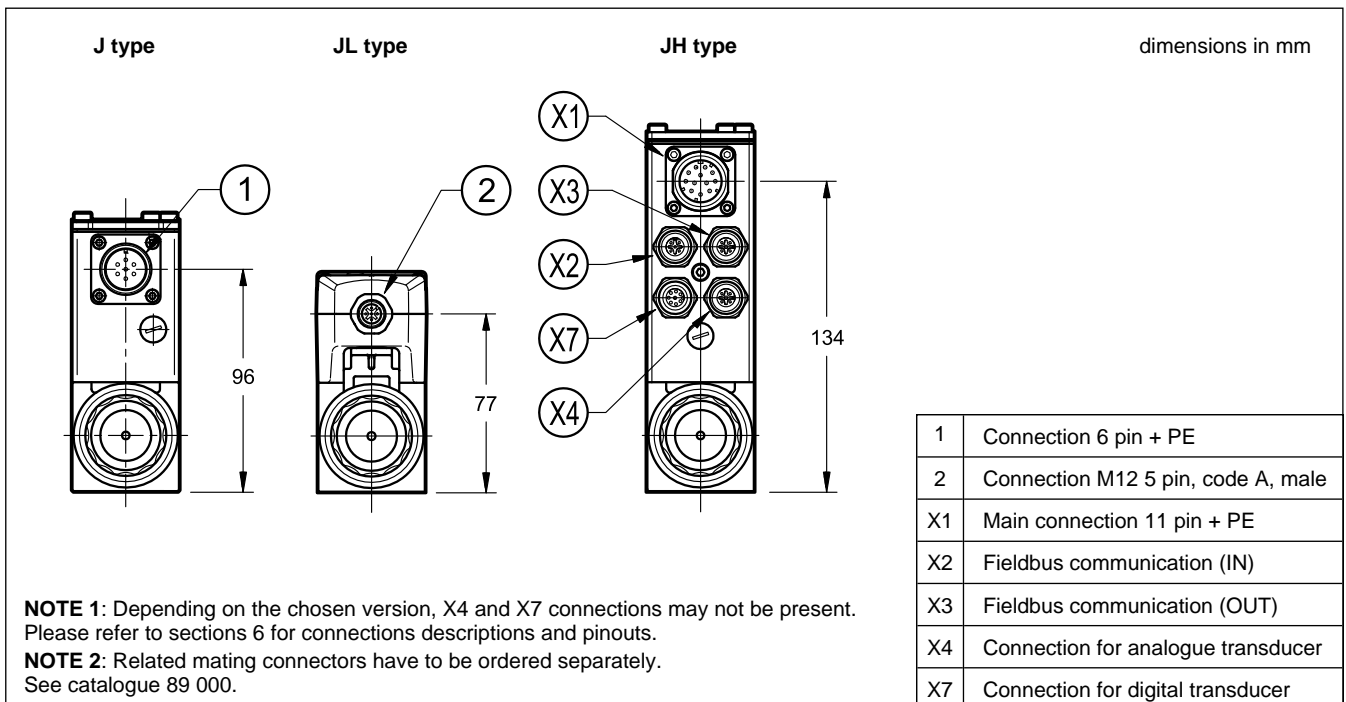

3 - ELECTRONICS COMMON DATA

Duty cycle		100% (continuous operation)
Protection class according to EN 60529		IP65/IP67 (NOTE)
Supply voltage	V DC	24 (from 19 to 30 VDC), ripple max 3 Vpp
Power consumption	VA	25
Maximum solenoid current	A	1.88
Fuse protection, external	A	2A time lag
Managed breakdowns		Overload and electronics overheating, cable breakdown, supply voltage failures
Electromagnetic compatibility (EMC) emissions EN 61000-6-4, immunity EN 61000-6-2		According to 2014/30/EU standards

NOTE: The IP degree is guaranteed only with mating connector of equivalent IP degree, installed and tightened correctly. Moreover, on the JH versions it is necessary to protect any unused connections with caps.

4 - PRE*J - STANDARD ELECTRONICS

4.1 - Electrical characteristics

Command signal:	voltage (E0) current (E1)	V DC mA	0 ÷ 10 (impedance Ri > 11 kOhm) 4 ÷ 20 (impedance Ri = 58 Ohm)
Monitor signal (pressure at transducer):	voltage (E0) current (E1)	V DC mA	0 ÷ 10 (impedance Ro > 1 kOhm) 4 ÷ 20 (impedance Ro = 500 Ohm)
Communication for diagnostic			LIN-bus Interface (by means of the optional kit)
Connection			6 pin + PE (MIL-C-5015-G - DIN EN 175201-804)

4.2 - On-board electronics diagrams

VERSION A - External Enable

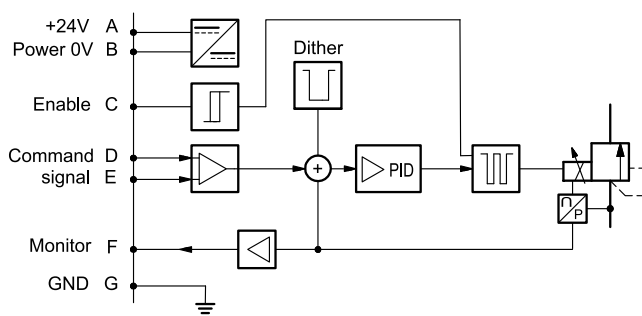

VERSION B - Internal Enable

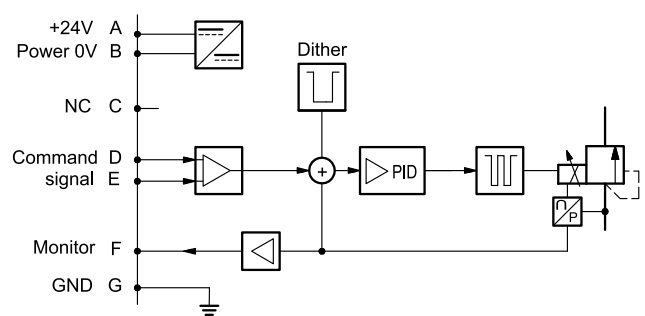

VERSION C - 0V Monitor

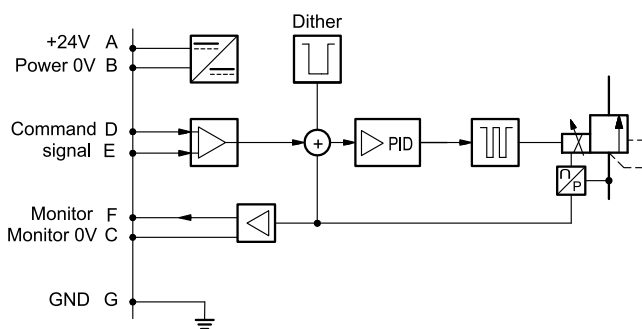

4.3 - Version with voltage command (E0)

The reference signal is between 0 ÷ 10V. The monitor feature of versions B and C becomes available with a delay of 0,5 sec from the power-on of the card.

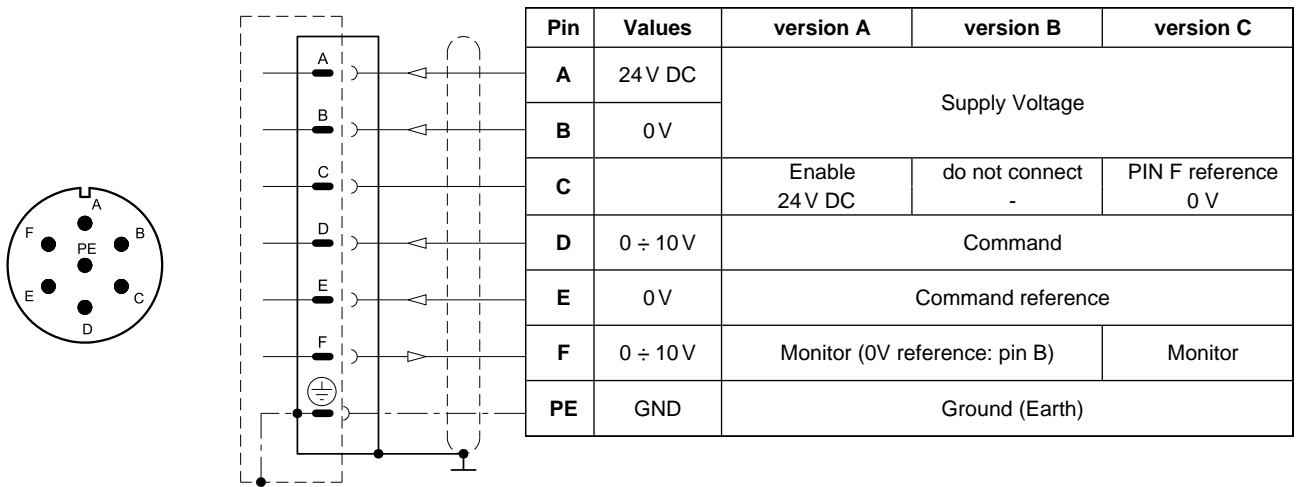
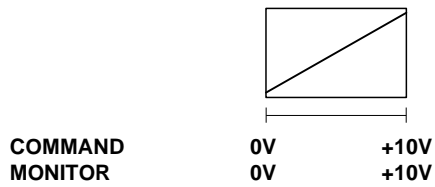

4.4 - Version with current command (E1)

The reference signal is supplied in current 4 ÷ 20 mA. If the current for command is lower, the card shows a breakdown cable error. To reset the error is sufficient to restore the signal.

The monitor feature of versions B and C becomes available with a delay of 0,5 sec from the power-on of the card.

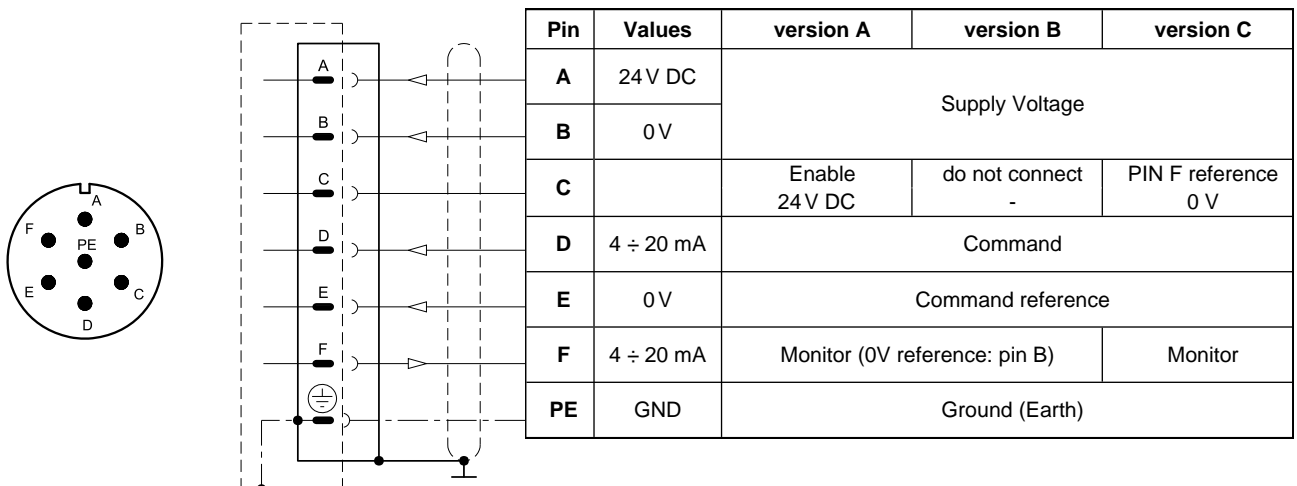
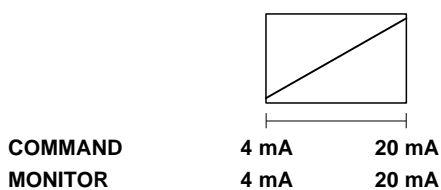

5 - PRE*JL - COMPACT ELECTRONICS

In IO-Link networks, the length of the connecting cables is limited to 20 metres. In CA versions, pin 3 and pin 5 are galvanic isolated up to 100 V to avoid earth loops.

5.1 - Electrical characteristics

Command signal: voltage (E0) current (E1)	V DC mA	0 ÷ 10 (impedance Ri > 11 kOhm) 4 ÷ 20 (impedance Ri = 58 Ohm)
Monitor signal (pressure at transducer): voltage (E0) current (E1)	V DC mA	0 ÷ 5 (impedance Ro > 1 kOhm) 4 ÷ 20 (impedance Ro = 500 Ohm)
IO-Link communication (IOL): Data rate	kBaud	IO-Link Port Class B 230.4
Can Open communication (CA): Data rate	kbit	10 ÷ 1000
Data register (IOL and CA versions only)		solenoid voltage supply, solenoid faults (shortcircuit, bad config, internal), box temperature, switch-on time, vibrations
Connection		5 pin M12 code A (IEC 61076-2-101)

5.2 - Pin tables

'E0' connection

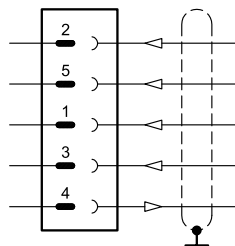

Pin	Values	Function
2	24 V DC	Supply voltage (solenoid and logic)
5	0 V	
1	0 ÷ 10 V	Command
3	0 V	Command reference
4	0 ÷ 5 V	Monitor (0V reference: pin 5)

'E1' connection

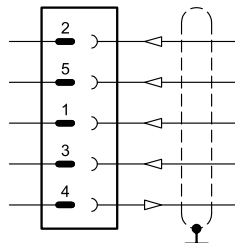

Pin	Values	Function
2	24 V DC	Supply voltage (solenoid and logic)
5	0 V	
1	4 ÷ 20 mA	Command
3	0 V	Command reference
4	4 ÷ 20 mA	Monitor (0V reference: pin 5)

'IOL' connection

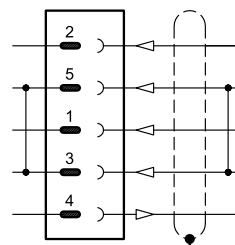

Pin	Values	Function
2	2L+ 24 V DC	Solenoid supply voltage
5	2L- 0 V (GND)	
1	1L+ +24 V DC	Logic and IO-Link supply voltage
3	1L- 0 V (GND)	
4	C/Q	IO-Link Communication

NOTE: Pin 3 and pin 5 are linked with each other in the valve electronics. The reference potentials 1L- and 2L- of the two supply voltages must also be linked with each other on the customer side.

'CA' connection

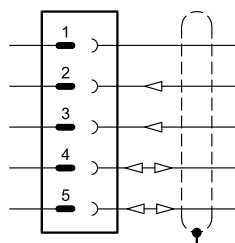

Pin	Values	Function
1	CAN_SH	Shield
2	24 V DC	Supply voltage
3	0 V (GND)	
4	CAN H	Bus line (high)
5	CAN_L	Bus line (low)

6 - PRE*JH - FIELDBUS ELECTRONICS

The 11+ PE pin connection allows separate supply voltage for electronics and solenoid.

Command - valve position schemes as for the standard electronics. Please refer to pictures in point 4.3 and 4.4.

6.1 - Electrical characteristics

Command signal: voltage (E0) current (E1) digital (FD)	V DC mA	0 ÷ 10 (impedance Ri > 11 kOhm) 4 ÷ 20 (impedance Ri = 58 Ohm) via fieldbus
Monitor signal (pressure at transducer): voltage (E0) current (E1)	V DC mA	0 ÷ 10 (impedance Ro > 1 kOhm) 4 ÷ 20 (impedance Ro = 500 Ohm)
Communication / diagnostic		via Bus register
Communication interface standards		IEC 61158
Communication physical layer		fast ethernet, insulated 100 Base TX
Power connection		11 pin + PE (DIN 43651)

6.2 - X1 Main connection pin table

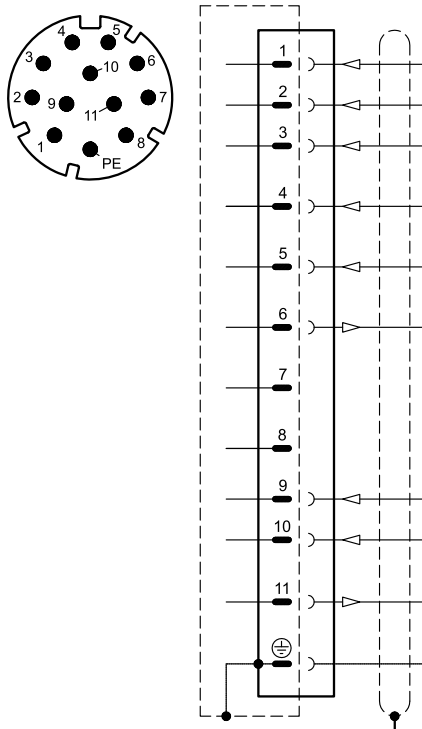

D1: one command			D0: full digital		
Pin	Values	Function	Pin	Values	Function
1	24 V DC	Main supply voltage	1	24 V DC	Main supply voltage
2	0V		2	0V	
3	24V DC	Enable	3	24V DC	Enable
4	0 ÷ 10V (E0) 4 ÷ 20 (E1)	Command	4	NC	do not connect
5	0V	Command reference signal	5	NC	do not connect
6	0 ÷ 10V (E0) 4 ÷ 20 (E1)	Monitor (0V reference pin 10)	6	NC	do not connect
7	NC	do not connect	7	NC	do not connect
8	NC	do not connect	8	NC	do not connect
9	24 V DC	Logic and control supply	9	24 V DC	Logic and control supply
10	0V		10	0V	
11	24 V DC	Fault (0V DC) or normal working (24V DC) (0V reference pin 2)	11	24 V DC	Fault (0V DC) or normal working (24V DC) (0V ref. pin 2)
12	GND	Ground (Earth)	12	GND	Ground (Earth)

6.3 - FIELDBUS connections

Please wire following guidelines provided by the related standards communication protocol. Any connections present and not used must be protected with special caps so as not to nullify the protection against atmospheric agents.

X2 (IN) connection: M12 D 4 pin female



Pin	Values	Function
1	TX+	Transmitter
2	RX+	Receiver
3	TX-	Transmitter
4	RX-	Receiver
HOUSING	shield	

X3 (OUT) connection: M12 D 4 pin female



Pin	Values	Function
1	TX+	Transmitter
2	RX+	Receiver
3	TX-	Transmitter
4	RX-	Receiver
HOUSING	shield	

NOTE: Shield connection on connector housing is recommended.

6.4 - Digital transducer connection

X7 connection: M12 A 8 pin female

VERSION 1: SSI type

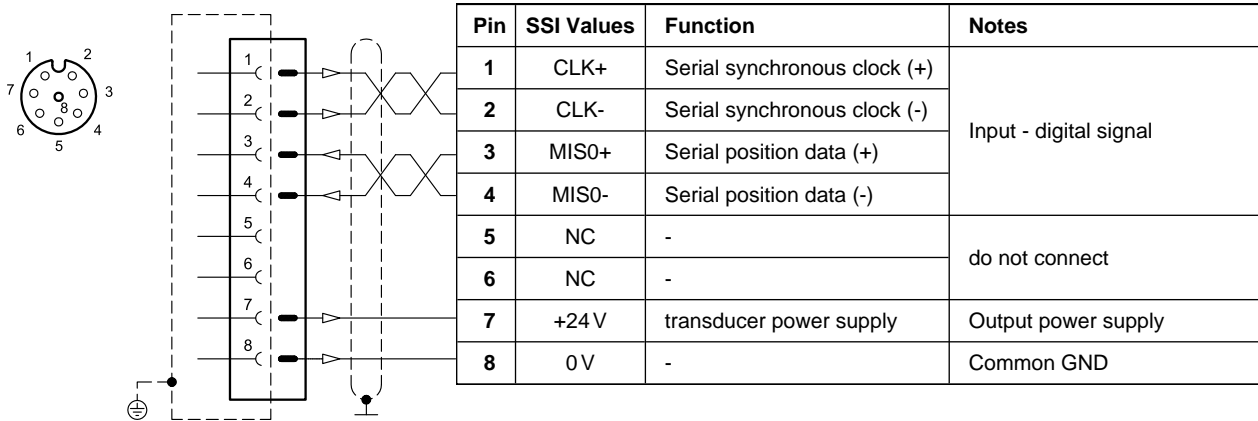

VERSION 2: ENCODER type

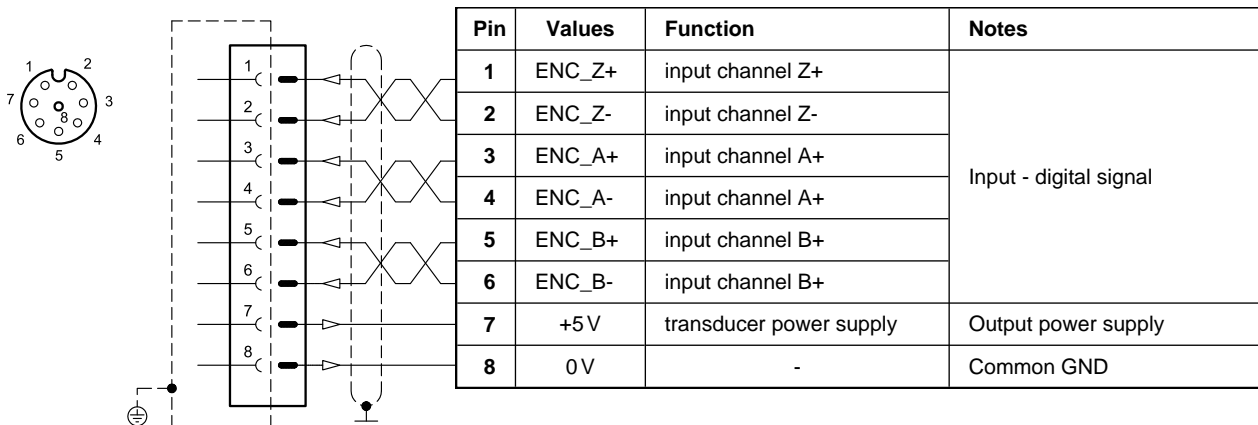

6.5 - Analogue transducer connection

X4 connection: M12 A 4 pin female

VERSION 1: single / double transducer

(single or double is a software-selectable option)

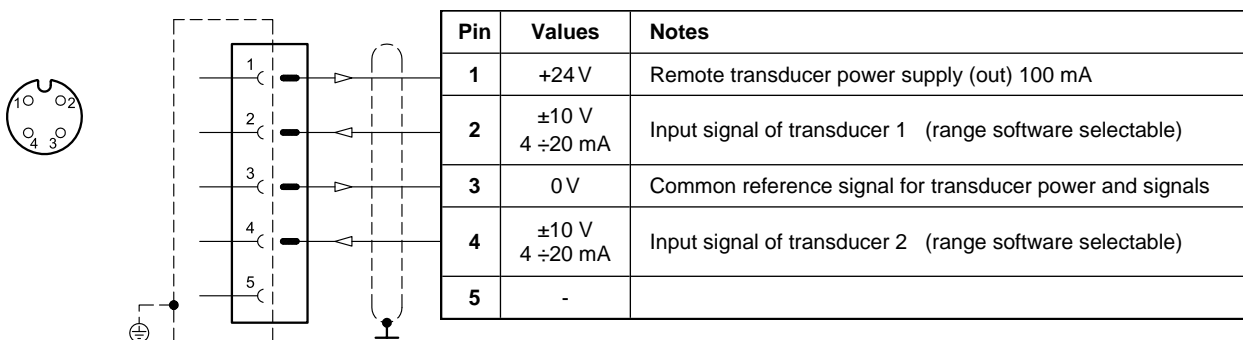

7 - CHARACTERISTIC CURVES

(measured with viscosity of 36 cSt at 50°C)

Typical control characteristics, according to the reference signal for available pressure control ranges, measured with input flow rate $Q = 50$ l/min. Characteristic curves measured without backpressure in T, with linearity and hysteresis compensation set by the onboard electronics.

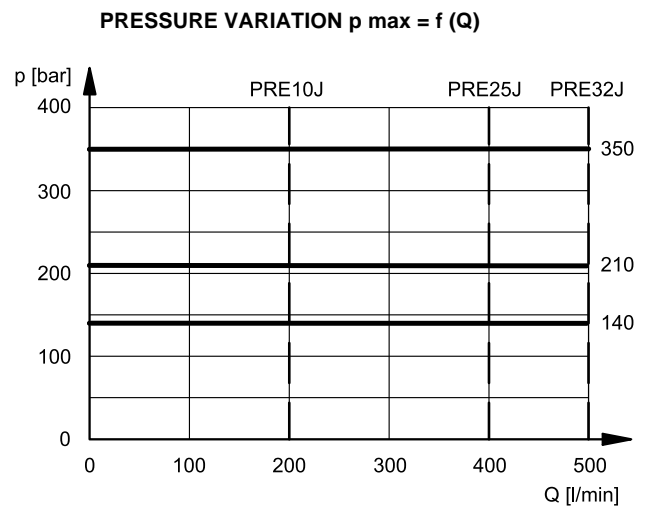
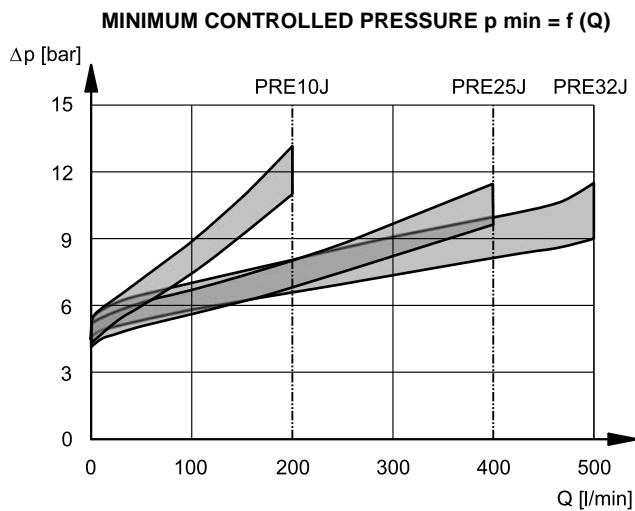
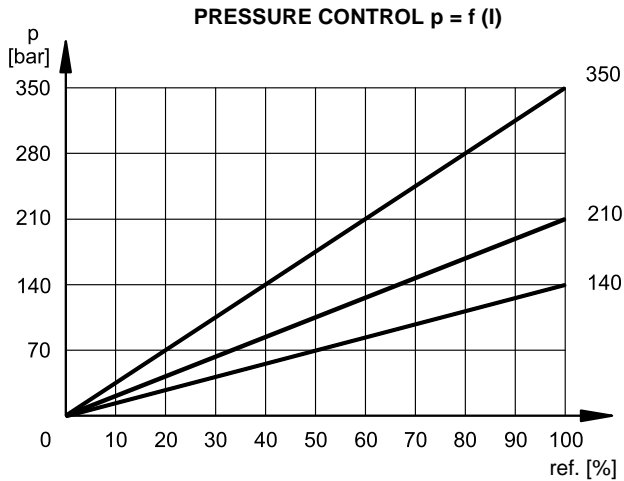

minimum controlled pressure for pressure control ranges between 140 bar and 350 bar.

8 - STEP RESPONSE

(obtained with mineral oil with viscosity of 36 cSt at 50 °C)

Response times obtained with PRE*J-210 valves, with an input flow rate of 50 l/min and a pressure oil volume of 2 litres. The response time is affected both by the flow rate and the oil volume in the pipework.

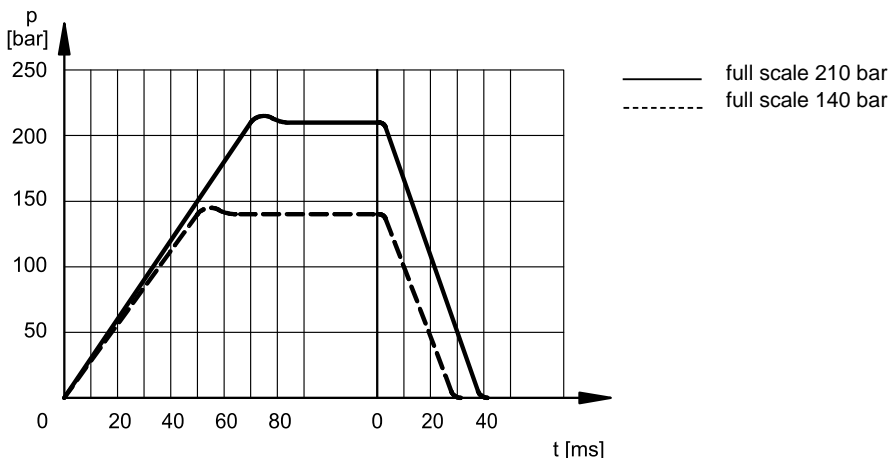

9 - PRE10J* - OVERALL AND MOUNTING DIMENSIONS

dimensions in mm

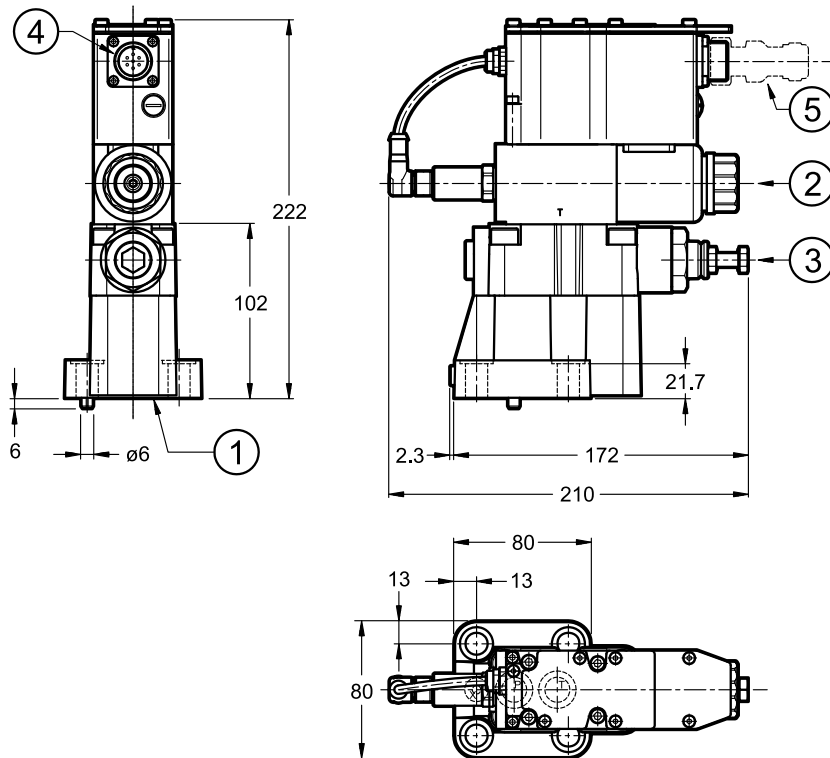

PRE10JL

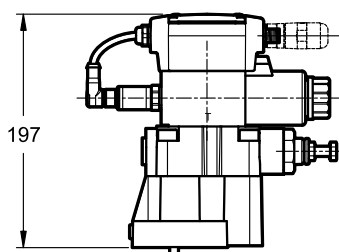

PRE10JH

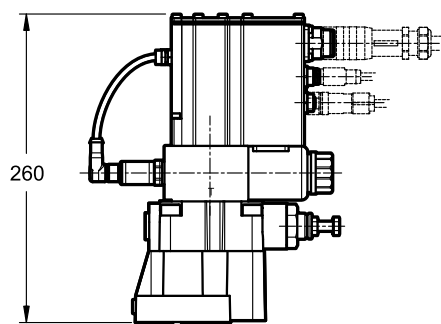

NOTE 1: at the first start up, or after a long period of no use, it is necessary to vent the air through the breather (2) placed at the end of the solenoid tube.

NOTE 2: Mounting interface at par. 12.

1	Mounting surface with sealing rings: 2 OR type 123 (17.86x2.62) - 90 Shore 1 OR type 109 (9.13x2.62) - 90 Shore
2	Breather: Allen key 4
3	Factory-set pressure relief valve
4	Main connection 6 pin + PE
5	Mating connector To be ordered separately. See catalogue 89 000

Valve fastening: 4 SHCS M12x40 - ISO 4762

Torque: 69 Nm (viti A8.8)

Thread of mounting holes: M12x20

10 - PRE25J* - OVERALL AND MOUNTING DIMENSIONS

dimensions in mm

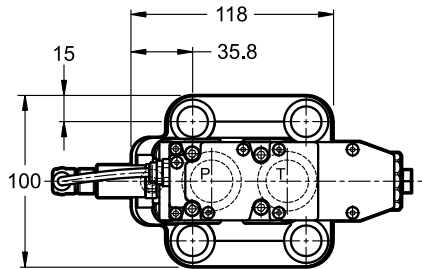
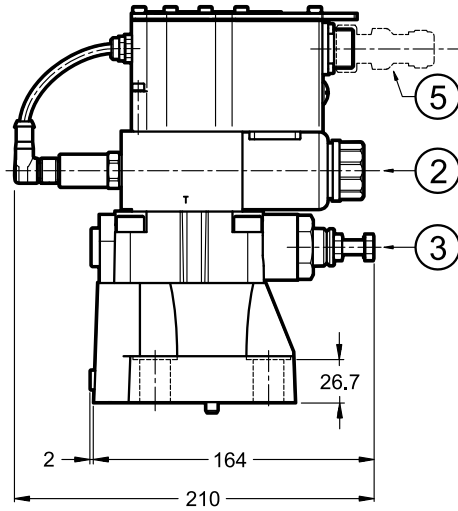
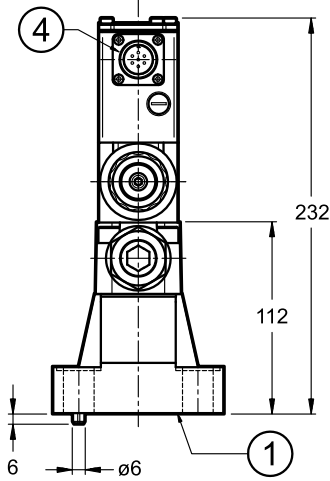

PRE25JL

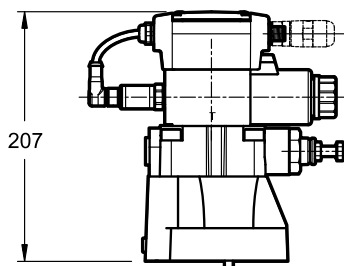

PRE25JH

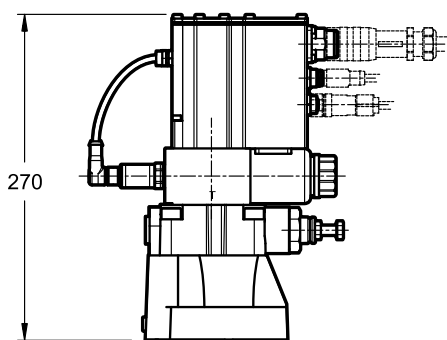

NOTE 1: at the first start up, or after a long period of no use, it is necessary to vent the air through the breather (2) placed at the end of the solenoid tube.

NOTE 2: Mounting interface at par. 12.

1	Mounting surface with sealing rings: 2 OR type 3118 (29.82x2.62) - 90 Shore 1 OR type 109 (9.13x2.62) - 90 Shore
2	Breather: Allen key 4
3	Factory-set pressure relief valve
4	Main connection 6 pin + PE
5	Mating connector To be ordered separately. See catalogue 89 000

Valve fastening: 4 SHCS M16x60 - ISO 4762

Torque: 170 Nm (viti A8.8)

Thread of mounting holes: M16x25

11 - PRE32J* - OVERALL AND MOUNTING DIMENSIONS

dimensions in mm

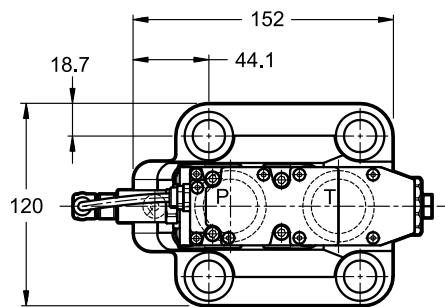
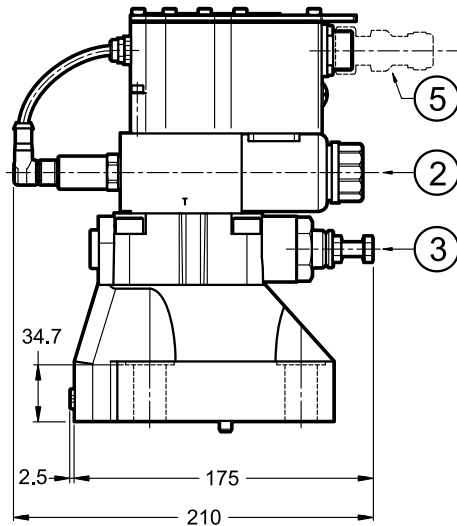
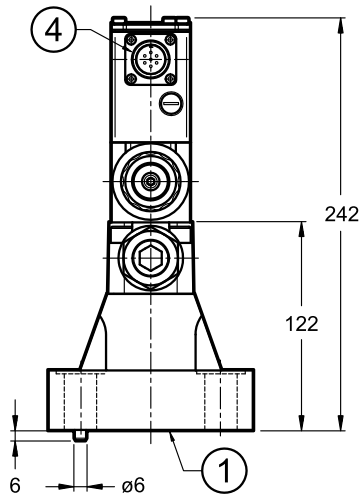

PRE32JL

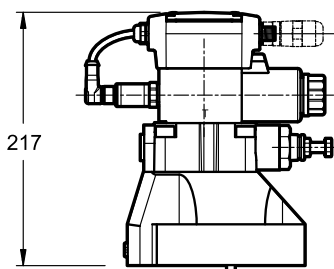

PRE32JH

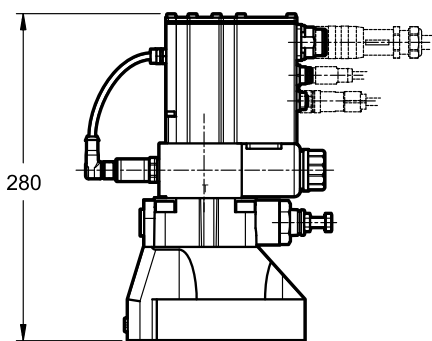

NOTE 1: at the first start up, or after a long period of no use, it is necessary to vent the air through the breather (2) placed at the end of the solenoid tube.

NOTE 2: Mounting interface at par. 12.

1	Mounting surface with sealing rings: 2 OR type 4137 (34.52x3.53) - 90 Shore 1 OR type 109 (9.13x2.62) - 90 Shore
2	Breather: Allen key 4
3	Factory-set pressure relief valve
4	Main connection 6 pin + PE
5	Mating electrical connector To be ordered separately. See catalogue 89 000

Valve fastening: 4 SHCS M18x60 - ISO 4762

Torque: 235 Nm (viti A8.8)

Thread of mounting holes: M18x27

12 - MOUNTING INTERFACES

PRE10J*:

ISO 6264-06-09-*97
(CETOP 4.4.2-2-R06-350)

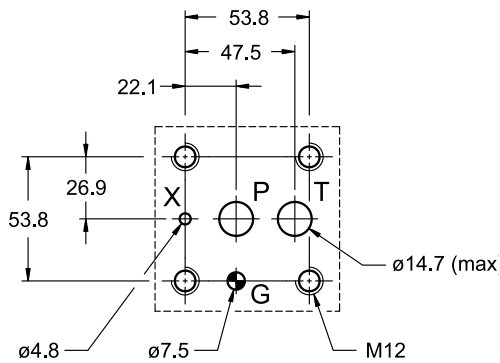

PRE25J*:

ISO 6264-08-13-*97
(CETOP 4.4.2-2-R08-350)

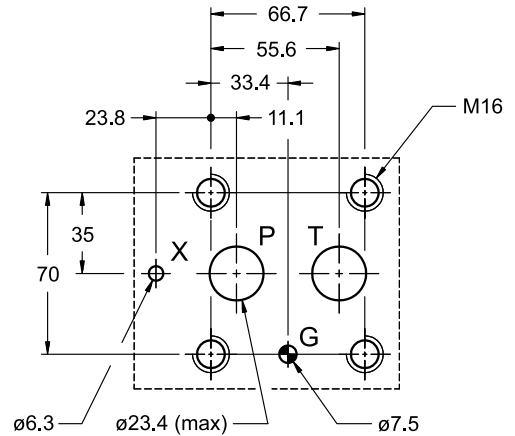

PRE32J*:

ISO 6264-10-17-*97
(CETOP 4.4.2-2-R10-350)

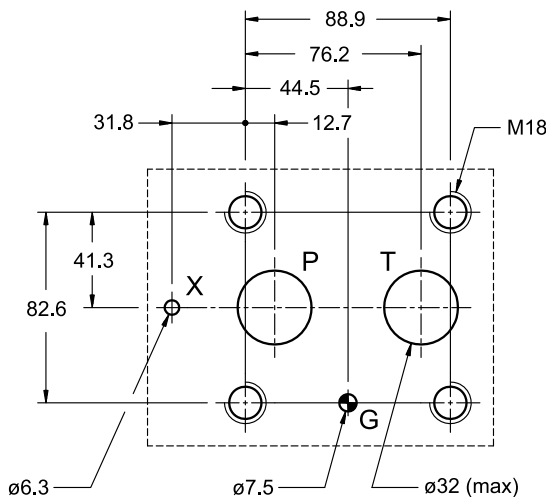

13 - HYDRAULIC FLUIDS

Use mineral oil-based hydraulic fluids HL or HM type, according to ISO 6743-4. For these fluids, use NBR seals. For fluids HFDR type (phosphate esters) use FPM seals (code V). For the use of other kinds of fluid such as HFA, HFB, HFC, please consult our technical department.

Using fluids at temperatures higher than 80 °C causes a faster degradation of the fluid and of the seals characteristics. The fluid must be preserved in its physical and chemical characteristics.

14 - INSTALLATION

We recommend to install the valves either in horizontal position, or vertical position with the solenoid downward. If the valve is installed in vertical position and with the solenoid upward, you must consider possible variations of the minimum controlled pressure, if compared to what is indicated in point 7.

Ensure that there is no air in the hydraulic circuit. In particular applications, can be necessary to vent the air entrapped in the solenoid tube, by using the appropriate drain screw in the solenoid tube.

Ensure the solenoid tube is always filled with oil. At the end of the operation, make sure of having correctly replaced the drain screw. Connect the valve T port directly to the tank.

Add any backpressure value detected in the T line to the controlled pressure value. Maximum admissible backpressure in the T line, under operational conditions, is 2 bar.

Valves are fixed by means of screws or tie rods on a flat surface with planarity and roughness equal to or better than those indicated in the relative symbols. If minimum values are not observed, fluid can easily leak between the valve and support surface.

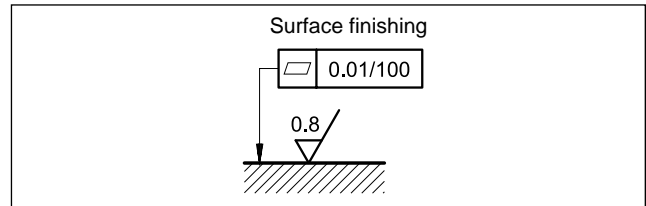

15 - ACCESSORIES

(to be ordered separately)

15.1 -Mating connectors

Mating connectors must be ordered separately. See catalogue 89 000.



For K11 and K16 versions we recommend the choice of a metal connector to avoid electromagnetic disturbances and to comply with EMC regulations on electromagnetic compatibility. If you opt for a plastic connector, make sure that it guarantees and maintains the IP and EMC protection characteristics of the valve.

15.2 - Mating connectors and caps for fieldbus communication and for sensors.

Duplomatic offers spare parts to be wired and also ready-to-use cord sets. Please refer to cat. 89 000.

15.3 - Connection cable

The optimal wiring provides for 7 isolated conductors, with separate screen for the signal wires (command, monitor) and an overall screen.

Cross section for power supply:

- up to 20 m cable length : 1,0 mm²
- up to 40 m cable length : 1,5 mm² (IO-Link excluded)

Cross section for signals (command, monitor):

- 0,50 mm²

15.4 - Kit for start-up LINPC-USB

Device for service start-up and diagnostic. See catalogue 89 850.

16 - SUBPLATES

(see catalogue 51 000)

	PRE10J*	PRE25J*	PRE32J*
Type	PMRQ3-AI4G rear ports	PMRQ5-AI5G rear ports	PMRQ7-AI7G rear ports
P, T port dimensions	P: 1/2" BSP T: 3/4" BSP	1" BSP	1" 1/4 BSP
X port dimensions	1/4" BSP	1/4" BSP	1/4" BSP