



PRM3

DIRECT OPERATED PRESSURE RELIEF VALVE

SERIES 10

MODULAR VERSION ISO 4401-03

p max 350 bar
Q max (see table of performances)

MOUNTING SURFACE

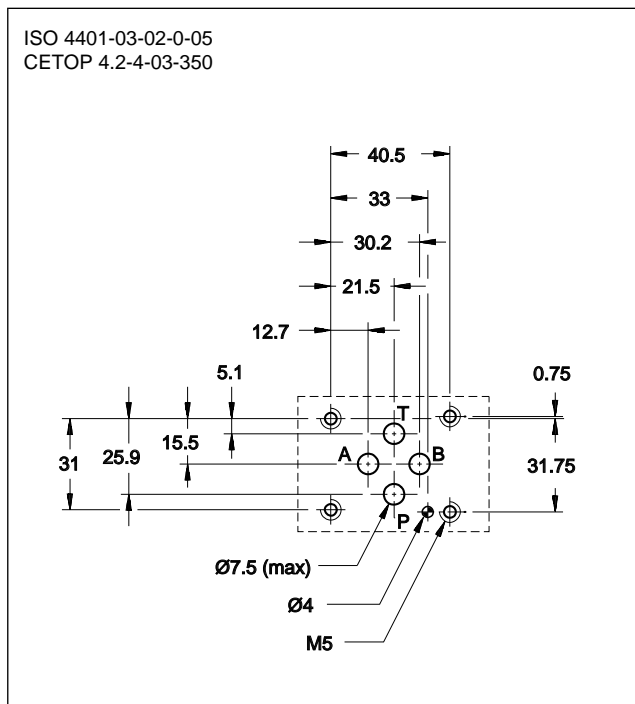

OPERATING PRINCIPLE

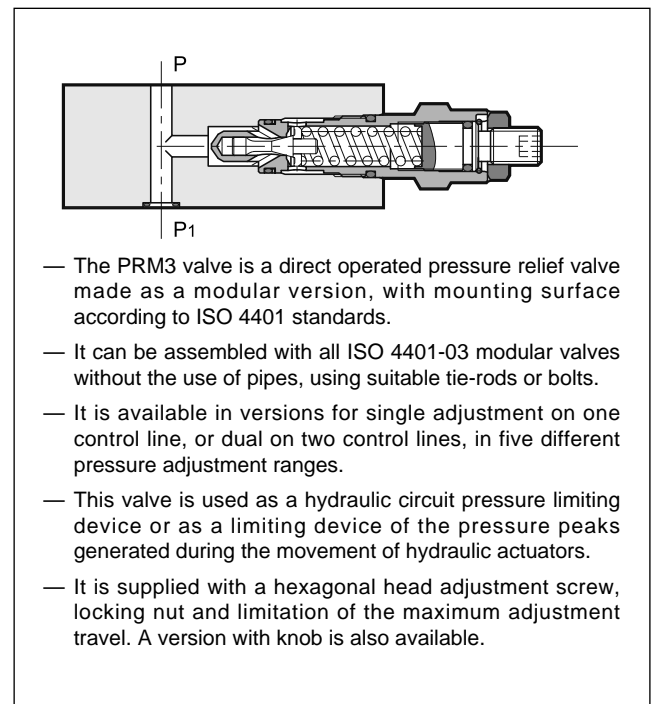

PERFORMANCES (measured with mineral oil of viscosity 36cSt at 50°C)

Maximum operating pressure	bar	350
Minimum controlled pressure	bar	see $\Delta p - Q$ diagram
Max flow rate in controlled lines Max flow rate in the free lines	l/min	50 75
Ambient temperature range	°C	-20 / +60
Fluid temperature range	°C	-20 / +80
Fluid viscosity range	cSt	10 ÷ 400
Fluid contamination degree	According to ISO 4406:1999 class 20/18/15	
Recommended viscosity	cSt	25
Mass: PRM3-PT, -AT, -BT, -BA PRM3-DT, -D	kg	1,3 1,8

HYDRAULIC SYMBOLS

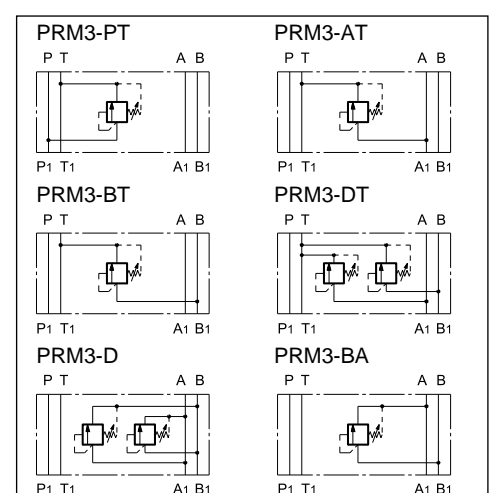

1 - IDENTIFICATION CODE

P	R	M	3	-		/ 10	/	
---	---	---	---	---	--	------	---	--

Pressure relief valve, direct operated

Modular version

ISO 4401-03 size

Versions:

PT = single on line P with discharge in T
AT = single on line A with discharge in T
BT = single on line B with discharge in T
DT = double on lines A-B with discharge in T
D = double on lines A-B with cross discharge
BA = single on line B with discharge in A

Pressure adjustment range:

025 = up to 25 bar **210** = up to 210 bar
070 = up to 70 bar **350** = up to 350 bar
140 = up to 140 bar

Option: /W7 surface treatment. Omit if not required (**NOTE**)

Adjustment type (See point 5):
S = with hexagonal socket screw (**standard**)
K = Adjustment knob

Seals:
N = NBR seals for mineral oils (**standard**)
V = FPM seals for special fluids

Series No. (the overall and mounting dimensions remain unchanged from 10 to 19)

NOTE: The standard valve is supplied with surface treatment of phosphating black. The zinc-nickel finishing on the valve body makes the valve suitable to ensure a salt spray resistance up to **240** hours. (test operated according to UNI EN ISO 9227 standards and test evaluation operated according to UNI EN ISO 10289 standards).

2 - CHARACTERISTIC CURVES

(values obtained with viscosity of 36 cSt at 50°C)

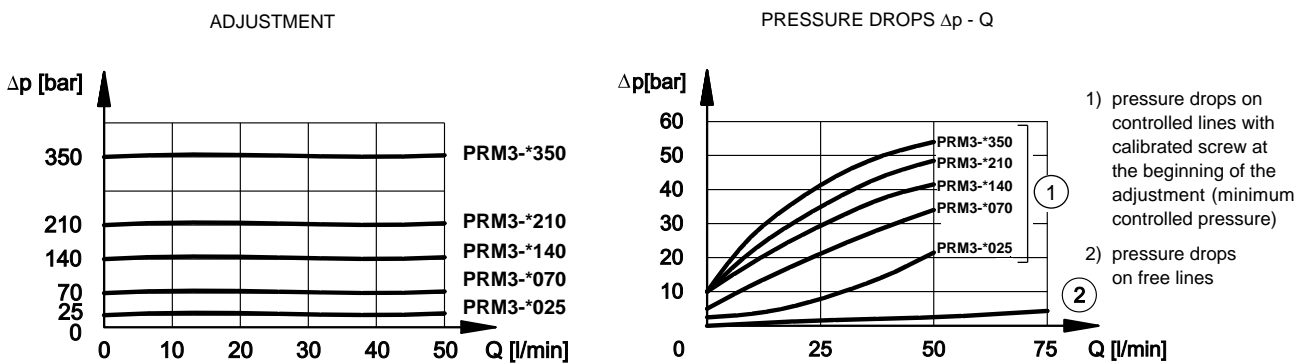

3 - HYDRAULIC FLUIDS

Use mineral oil-based hydraulic fluids HL or HM type, according to ISO 6743-4. For these fluids, use NBR seals (code N). For fluids HFDR type (phosphate esters) use FPM seals (code V). For the use of other kinds of fluid such as HFA, HFB, HFC, please consult our technical department.

Using fluids at temperatures higher than 80 °C causes a faster degradation of the fluid and of the seals characteristics. The fluid must be preserved in its physical and chemical characteristics.

4 - OVERALL AND MOUNTING DIMENSIONS

dimensions in mm

PRM3-D, PRM3-DT

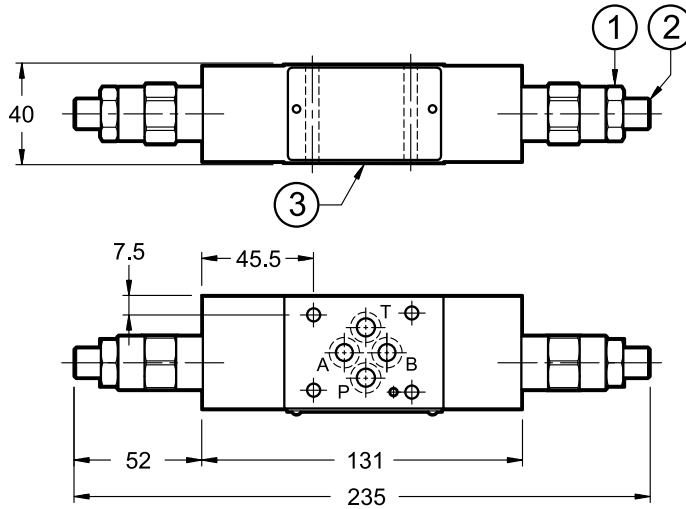

PRM3-PT, PRM3-BA, PRM3-BT

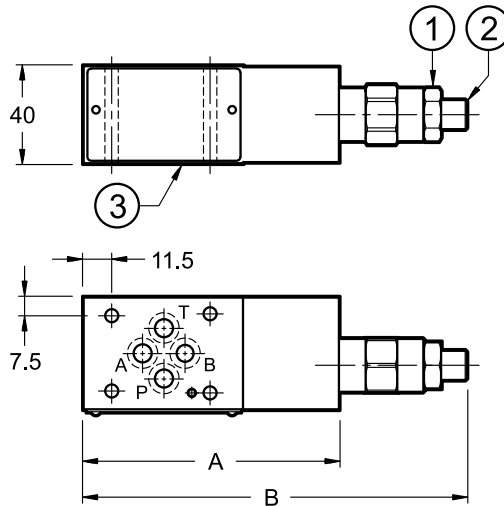

	A	B
PRM3-PT	105	157
PRM3-BA	100	152
PRM3-BT	100	152

1	Locking nut: spanner 19
2	Hex socket adjustment screw: spanner 6 (standard) Rotate clockwise to increase pressure
3	Mounting surface with sealing rings: 4 OR type 2037 (9.25x1.78) 90 Shore

dimensions in mm

PRM3-AT

Technical drawing of the PRM3-AT valve. The side view shows a cylindrical body with a diameter of 40 mm. Callout 1 points to the hex socket adjustment screw, callout 2 to the locking nut, and callout 3 to the mounting surface. The front view shows a rectangular face with a width of 100 mm and a total length of 152 mm. The distance from the front face to the center of the adjustment screw is 46 mm, and the distance from the front face to the center of the locking nut is 7.5 mm. The front face features four ports labeled A, B, P, and T.

1	Locking nut: spanner 19
2	Hex socket adjustment screw: spanner 6 (standard) Rotate clockwise to increase pressure
3	Mounting surface with sealing rings: 4 OR type 2037 (9.25x1.78) 90 Shore

5 - ADJUSTMENT KNOB

The standard valve is supplied with the hex socket adjustment screw. A version with knob is also available.

Use the letter **K** in the identification code to order this version (see point 1).

dimensions in mm

Technical drawing of the adjustment knob assembly. It shows a cylindrical knob with a diameter of 80 mm. Callout 1 points to the adjustment knob and callout 2 points to the locking ring.

1	Adjustment knob: K
2	Locking ring