



# VR\*-P CHECK VALVES

## SUBPLATE MOUNTING

**p** max (see table of performances)  
**Q** max (see table of performances)

## OPERATING PRINCIPLE

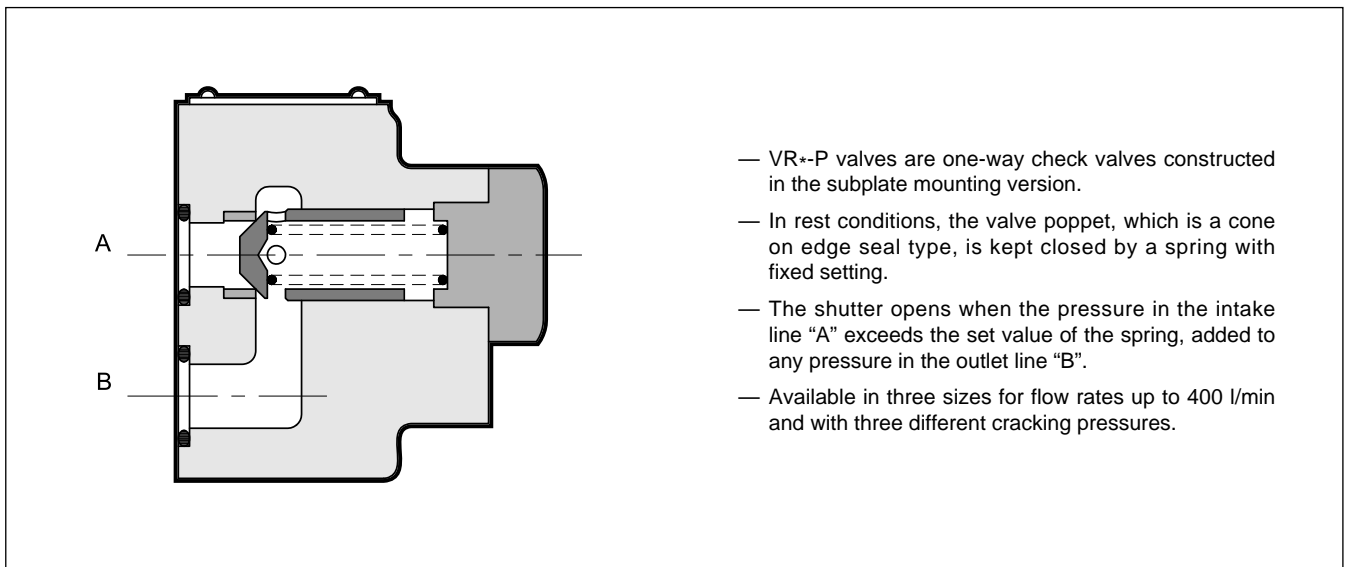

## TECHNICAL SPECIFICATIONS

Valve code	Nominal dimension	Maximum flow rate [l/min]	Mass [kg]	Max. operating pressure [bar]
VR3 - P	3/8"	100	2,3	350
VR5 - P	3/4"	200	4,8	350
VR7 - P	1 1/4"	400	9	250

Ambient temperature range	°C	-20 / +60
Fluid temperature range	°C	-20 / +80
Fluid viscosity range	cSt	10 ÷ 400
Fluid contamination degree	According to ISO 4406:1999 class 20/18/15	
Recommended viscosity	cSt	25

## HYDRAULIC SYMBOL

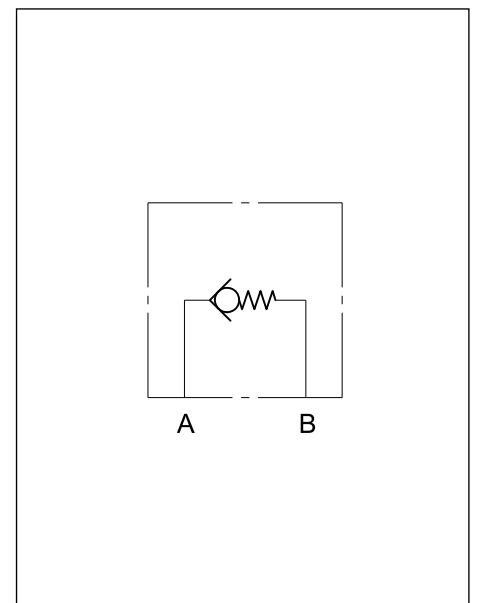

## 1 - IDENTIFICATION CODE

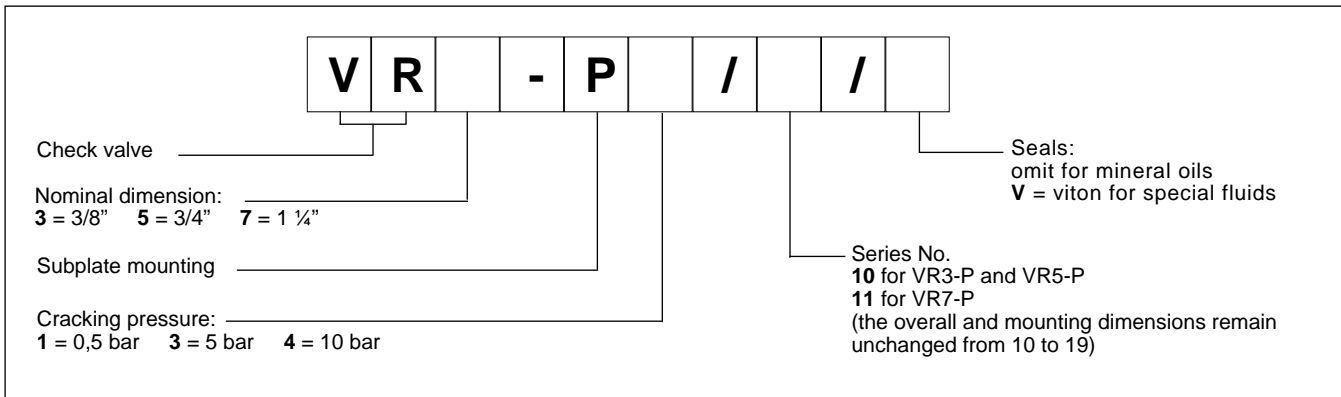

## 2 - CHARACTERISTIC CURVES (values obtained with viscosity 36 cSt at 50°C)

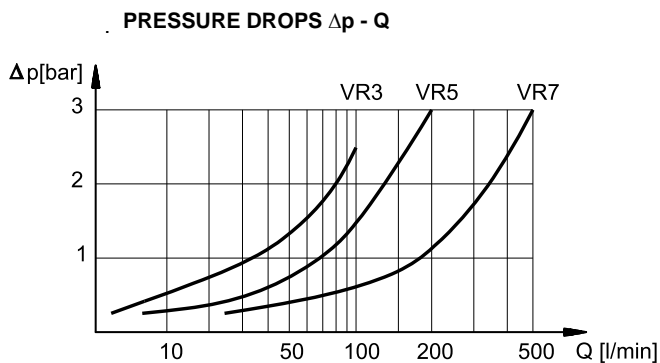

**NOTE:** Add the cracking pressure to the values shown in the diagram.

## 3 - HYDRAULIC FLUIDS

Use mineral oil-based hydraulic fluids HL or HM type, according to ISO 6743-4. For these fluids, use NBR seals. For fluids HFDR type (phosphate esters) use FPM seals (code V). For the use of other kinds of fluid such as HFA, HFB, HFC, please consult our technical department. Using fluids at temperatures higher than 80 °C causes a faster degradation of the fluid and of the seals characteristics.

The fluid must be preserved in its physical and chemical characteristics.

4 - VR3-P OVERALL AND MOUNTING DIMENSIONS

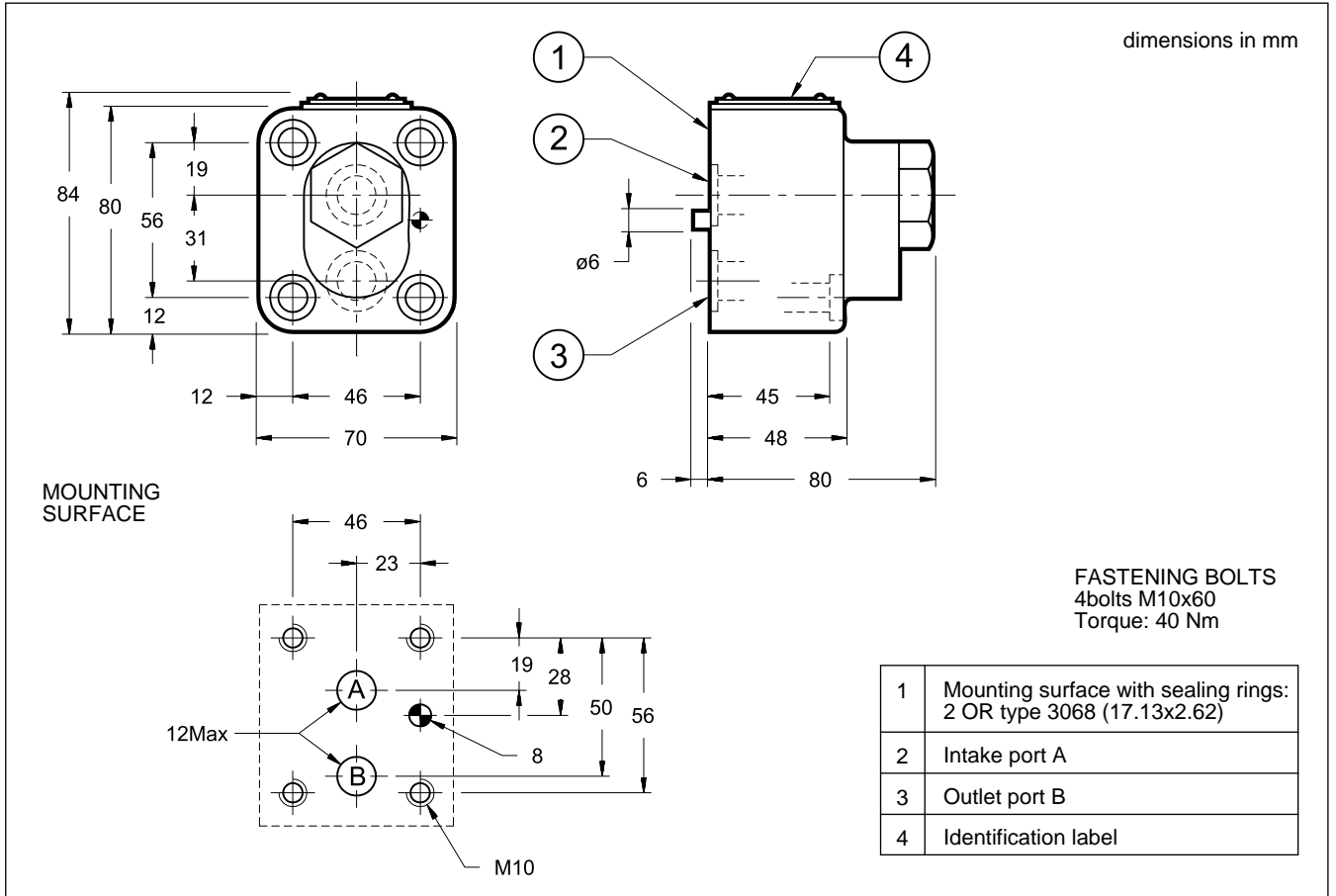

5 - VR5-P OVERALL AND MOUNTING DIMENSIONS

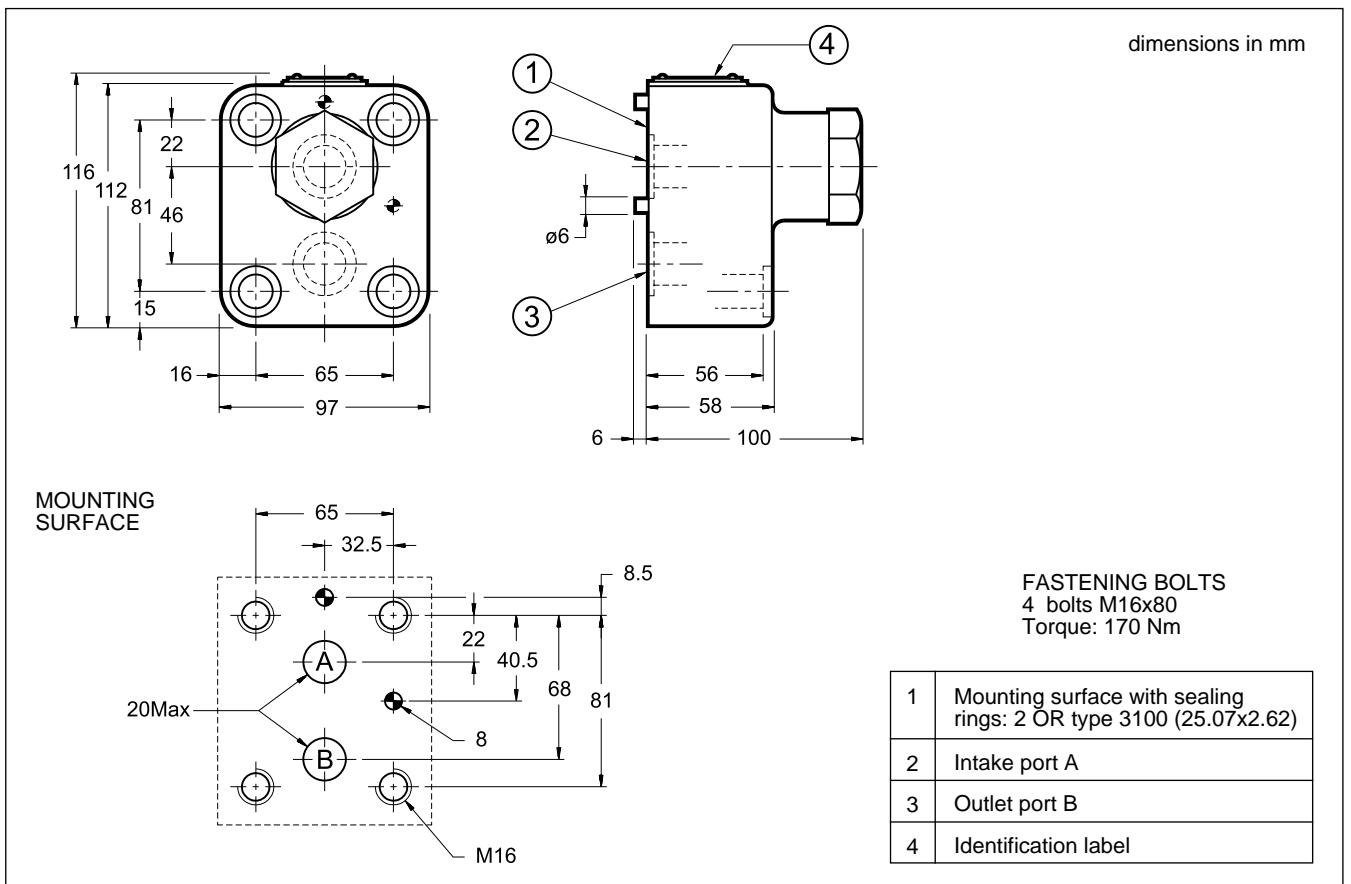

## 6 - VR7-P OVERALL AND MOUNTING DIMENSIONS

