



BDL1

STACKABLE DIRECTIONAL CONTROL VALVES SERIES 10

p max 350 bar
Q max 15 l/min

OPERATING PRINCIPLE

- BDL1 is an assemblage of stackable valves, very versatile thanks to the modular design.
- Stackable elements have been designed to be assembled in parallel connection, mounting up to 8 stackable directional valves.
- BD* assemblies are suitable for compact applications, mainly in mobile industries and in mini-power packs.
- The directional valves have a thickness of 28 mm and 1/8" BSP connections on working ports.
- Inlet elements have P and T ports 1/4" BSP.

PERFORMANCES

(obtained with mineral oil with viscosity of 36 cSt at 50°C)

Maximum operating pressure: - P-A-B ports - T / T1 ports	bar	350 280
Maximum flowrate	l/min	15
Pressure drops $\Delta p - Q$	see paragraph 3	
Electrical characteristics	see paragraph 6	
Operating limits	see paragraph 4	
Electrical connections	see paragraph 7	
Ambient temperature range	°C	-20 / +50
Fluid temperature range	°C	-20 / +80
Fluid viscosity range	cSt	10 ÷ 400
Fluid contamination degree	According to ISO 4406:1999 class 20/18/15	
Recommended viscosity	cSt	25
Mass (directional valve)	kg	0.8
Surface treatment of inlet and outlet elements and of valve body	zinc-nickel	

HYDRAULIC SYMBOL

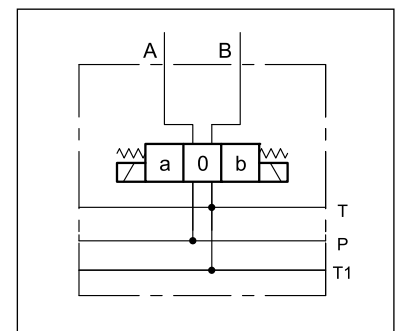

1 - IDENTIFICATION CODES OF SEPARATE ELEMENTS

Here below are shown the identification codes for the separate elements of the stackable valve.

1.1 - Directional valve element

	BD	L	1	-	B18	-	/	10	-		/	
--	-----------	----------	----------	----------	------------	----------	----------	-----------	----------	--	----------	--

Stack directional valve element, on-off

13 mm solenoid tube

Size : thickness 28 mm

Ports 1/8" BSP

Spool type (see point 1.2)

Series no. (the overall and mounting dimensions remain unchanged from 10 to 19)

Seals: **N** = NBR seals for mineral oil (**standard**)
V = FPM seals for special fluids

Manual override:
Omit for pin manual override integrated in the tube (**standard**).
CM = manual override boot protected

Coil electrical connection:
K1 = plug for connector type EN 175301-803 (ex DIN 43650) (**standard**)
K2 = plug for connector type AMP JUNIOR
K7 = plug DEUTSCH DT04-2P for male connector type DEUTSCH DT06-2S

Coil type:
DC coils
D12 = 12 V
D24 = 24 V
D00 = valve without coil supplied with locking ring

NOTE: A galvanic surface treatment zinc-nickel is applied to body elements and plates, making the assembly suitable to withstand a salt spray exposure time of **600** hours (test carried out according to the UNI EN ISO 9227 and assessment test carried out according to UNI EN ISO 10289).

1.2 - Available spools

<p>Type S: 2 solenoids - 3 positions spring centring</p> <p>S1</p> <p>S3</p>	<p>Type SA*: 1 solenoid side A 2 positions (central + external) spring centring</p> <p>SA1</p> <p>SA3</p>	<p>Type SB*: 1 solenoid side B 2 positions (central + external) spring centring</p> <p>SB1</p> <p>SB3</p>
<p>Type TA*: 1 solenoid side A 2 external positions with return spring</p> <p>TA</p>		<p>Type TB*: 1 solenoid side B 2 external positions with return spring</p> <p>TB</p>

1.3 - Inlet element without pressure control valve

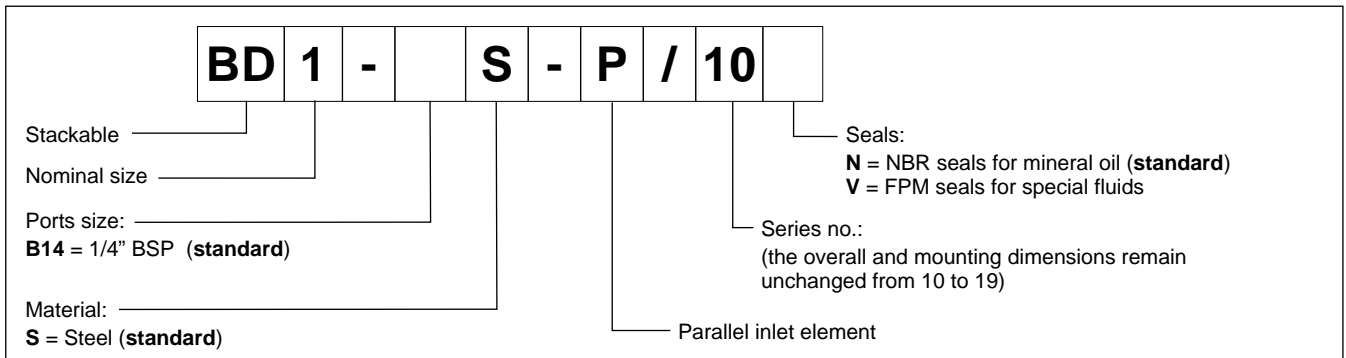

1.4 - Inlet element with pressure control valve

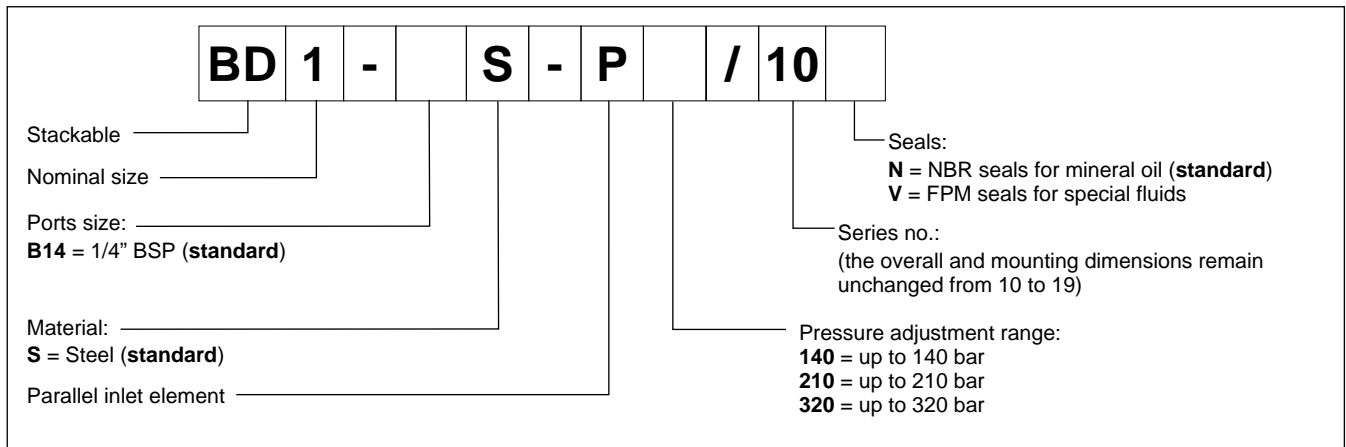

1.5 - End plate

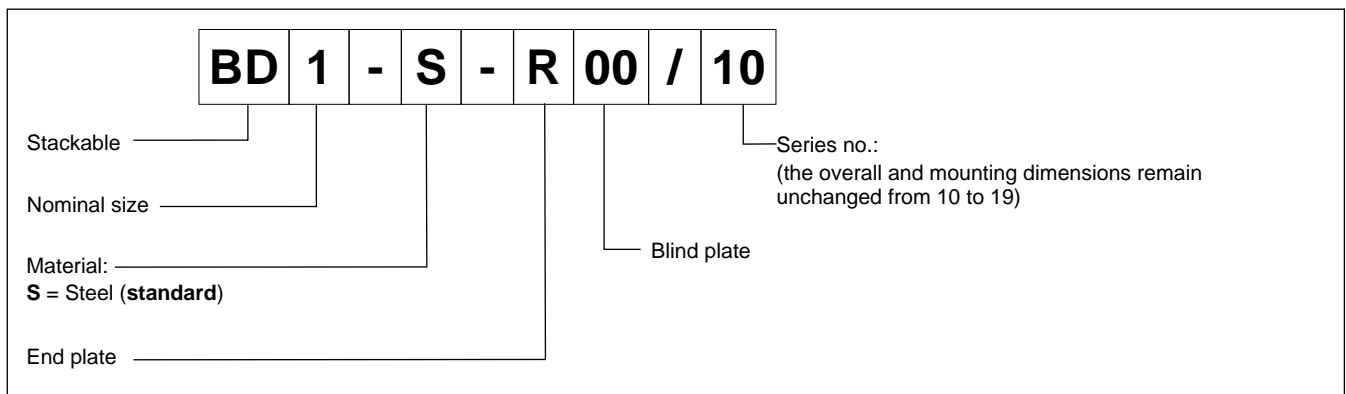

2 - HYDRAULIC FLUIDS

Use mineral oil-based hydraulic fluids HL or HM type, according to ISO 6743-4. For these fluids, use NBR seals (code N). For fluids HFDR type (phosphate esters) use FPM seals (code V). For the use of other kinds of fluid such as HFA, HFB, HFC, please consult our technical department.

Using fluids at temperatures higher than 80 °C causes a faster degradation of the fluid and of the seals characteristics. The fluid must be preserved in its physical and chemical characteristics.

3 - CHARACTERISTIC CURVES

(values obtained with viscosity 36 cSt at 50 °C)

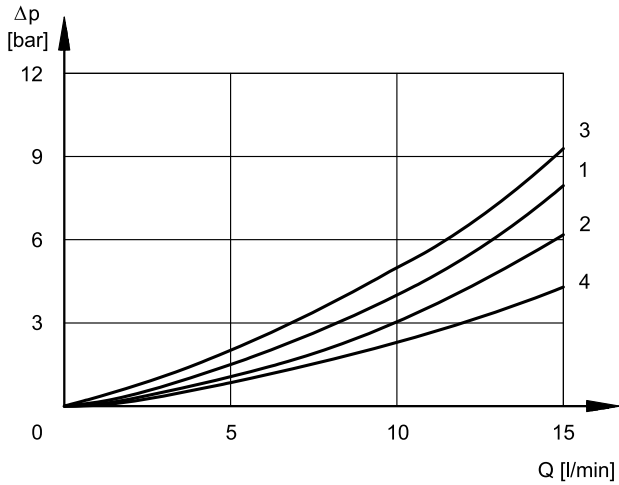

SPOOL TYPE	FLOW DIRECTION			
	P→A	P→B	A→T	B→T
	CURVES ON GRAPHS			
S1, SA1, SB1	1	1	2	2
S3, SA3, SB3	3	3	4	4
TA, TB	1	1	2	2

Please refer to the curve 2 for pressure drops of S3 spool in central position.

4 - OPERATING LIMITS

The curves define the flow rate operating fields according to the valve pressure of the different versions. The values have been obtained according to ISO 6403 norm with solenoids at rated temperature and supplied with voltage equal to 90% of the nominal voltage.

Values obtained with mineral oil, viscosity 36 cSt, temperature 50 °C and filtration according to ISO 4406:1999 class 18/16/13.

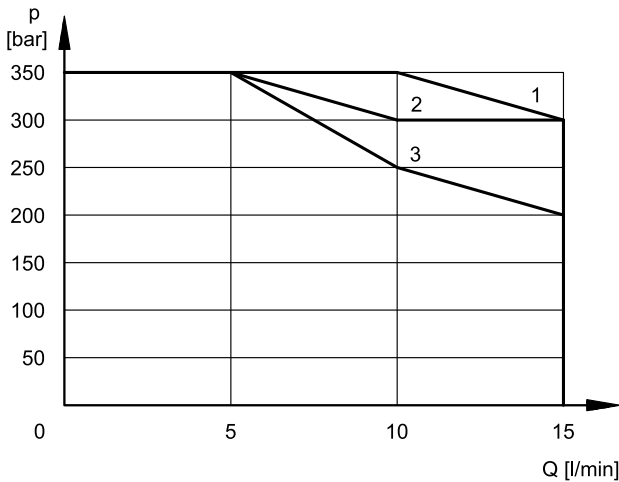

SPOOL TYPE	
S1	1
S3	3
TA, TB	2

5 - SWITCHING TIMES

Values obtained according to ISO 6403, with mineral oil with viscosity 36 cSt at 50°C.

TIMES [ms] (±10%)	ENERGIZING	DE-ENERGIZING
BDL1	25 ÷ 75	15 ÷ 25

6 - ELECTRICAL FEATURES

6.1 - Solenoids

These are essentially made up of two parts: tube and coil. The tube is threaded into the valve body and includes the armature that moves immersed in oil, without wear. The inner part, in contact with the oil in the return line, ensures heat dissipation. The coil is fastened to the tube by a threaded ring, and can be rotated to suit the available space.

SUPPLY VOLTAGE FLUCTUATION	± 10% Vnom
MAX SWITCH ON FREQUENCY	10.000 ins/hr
DUTY CYCLE	100%
ELECTROMAGNETIC COMPATIBILITY (EMC)	In compliance with 2014/30/EU
LOW VOLTAGE	In compliance with 2014/35/EU
CLASS OF PROTECTION Coil insulation (VDE 0580) Impregnation	class H class H

6.2 - Protection from atmospheric agents IEC 60529

The IP protection degree is guaranteed only with both valve and connectors of an equivalent IP degree, correctly connected and installed.

The protection degree IP69K is not taken into account in IEC 60529 but it is included in ISO 20653.

protection referred to	electrical connection		whole valve
	IP65	IP69 IP69K	IP65
K1 EN 175301-803	x		x
K2 AMP JUNIOR	x		x
K7 DEUTSCH DT04 male	x	x	x

Current and absorbed power

(values ±5 %)

	Resistance 20°C [Ω]	Absorbed current [A]	Absorbed power [W]	Coil code		
				K1	K2	K7
D12	6.6	1.8	21.8	1903710	1903720	1903730
D24	27	0.9	21.6	1903711	1903721	1903731

7 - ELECTRICAL CONNECTIONS

connection for EN 175301-803
(ex DIN 43650) connector
code **K1 (standard)**

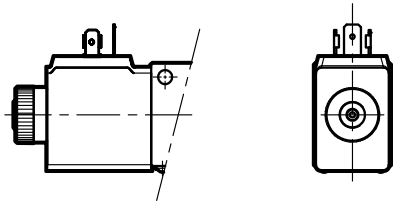

connection for AMP JUNIOR connector
code **K2**

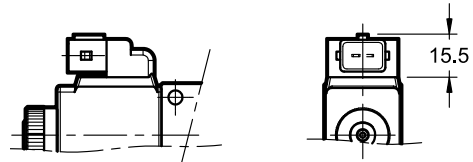

DEUTSCH DT04-2P connection for DEUTSCH
DT06-2S male connector
code **WK7**

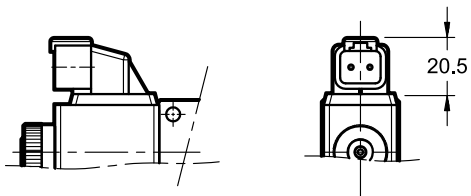

8 - ELECTRICAL CONNECTORS

The solenoid valves are supplied without connectors. Connectors for electrical connections K1 (EN 175301-803, ex DIN 43650) can be ordered separately with code 0672129.

9 - INSTALLATION

The stack valve assembly can be installed in any position without impair the proper operation.

9.1 - Fixing and tie-rods

Fixing kit are available. Please contact the technical dept. for dimensional check and ordering codes.

10 - OVERALL AND MOUNTING DIMENSIONS OF DIRECTIONAL VALVES

10.1 - Mounting surface

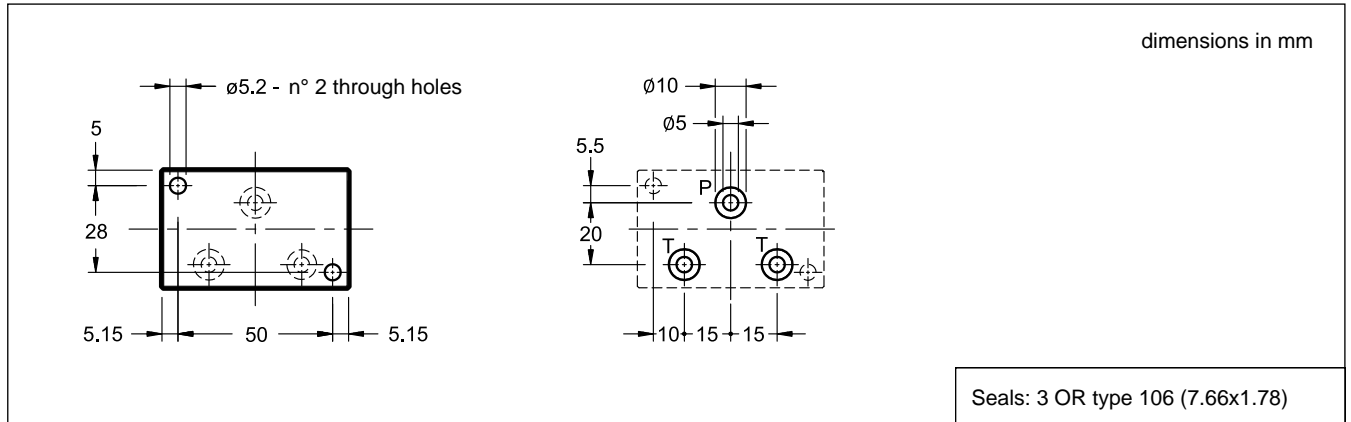

10.2 - Directional valve element - solenoid tube $\varnothing 13$

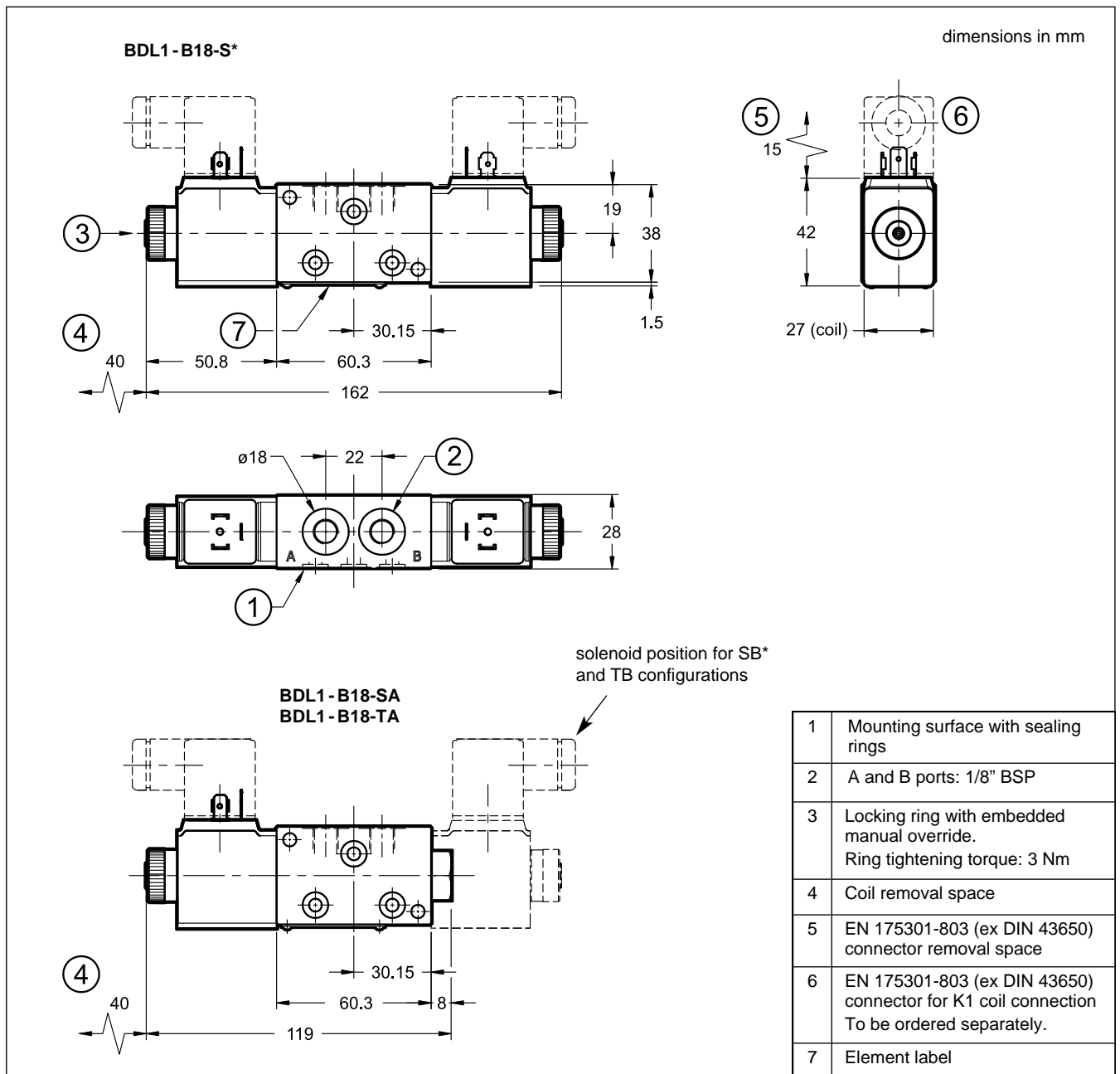

10.3 - CM - Boot protected manual override

The version with boot protected manual override is available.
To order it, add /CM at the end of the identification code

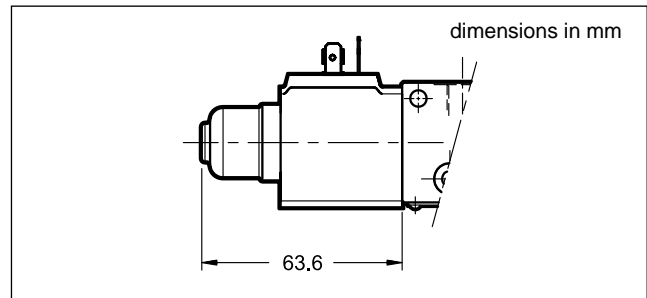

11 - DIMENSIONS OF INLET AND OUTLET ELEMENTS

11.1 - Inlet elements

BD1-B14S-P
without pressure control valve

dimensions in mm

1	Mounting surface with sealing rings: 3 OR type 106 (6.75x1.78)
2	P and T ports: 1/4" BSP
3	Element label

BD1-B14S-P***
with pressure control valve

1	Pressure control valve
2	Locking nut: spanner 13
3	Socket hex adjustment screw: Allen key 4 Clockwise rotation to increase pressure
4	Mounting surface with sealing rings: 3 OR type 106 (6.75x1.78)
5	P and T ports: 1/4" BSP
6	Element label

11.3 - End plate

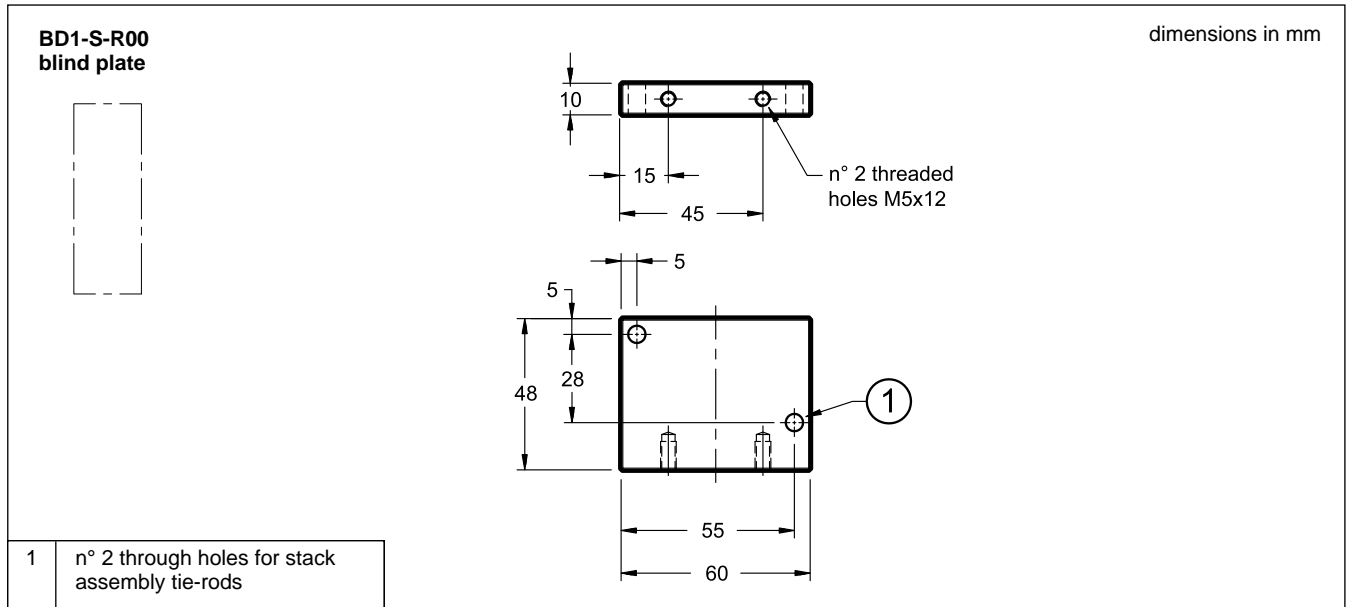

12 - IDENTIFICATION CODE FOR STACK VALVE ASSEMBLY

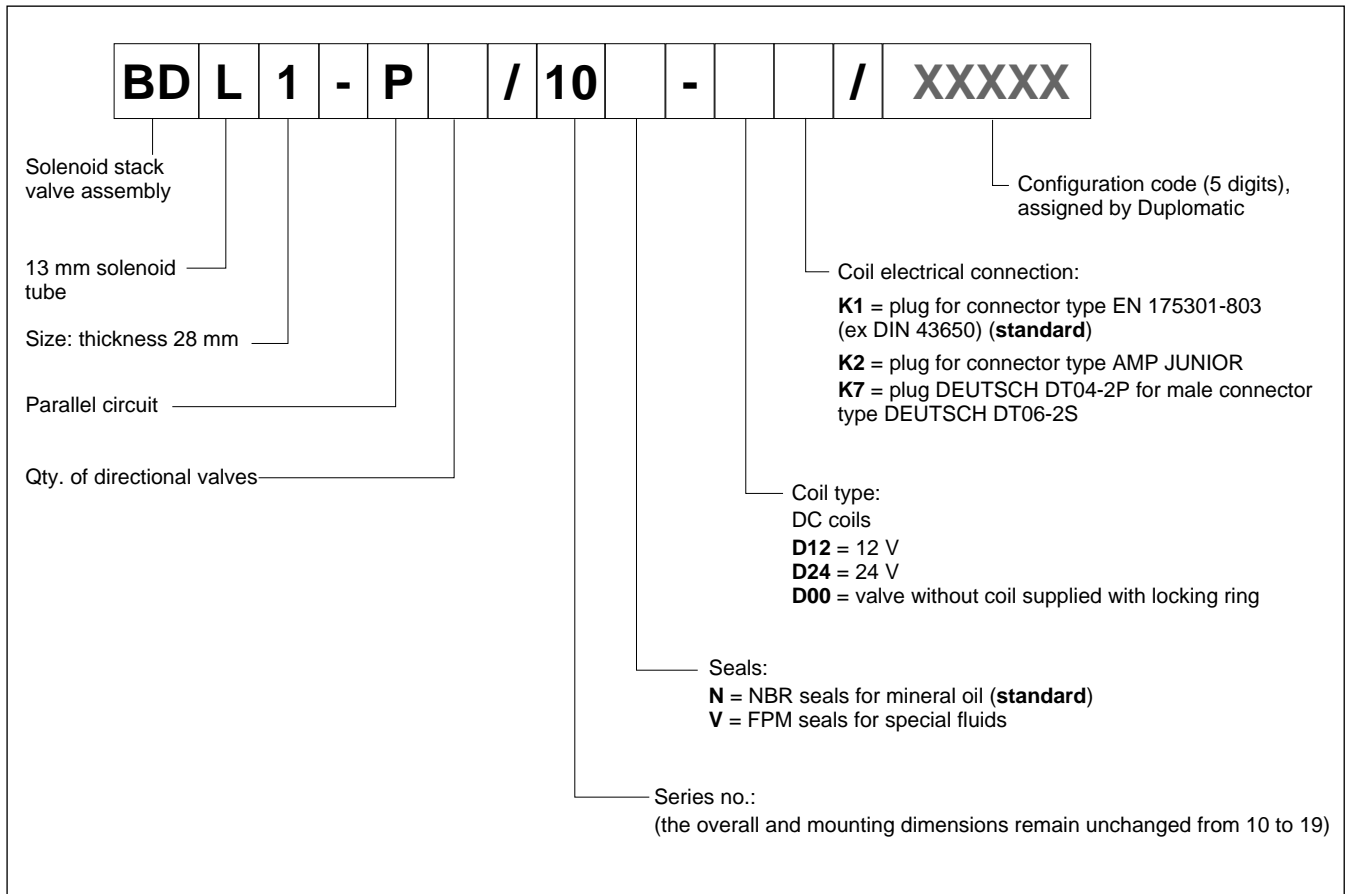

13 - ASSEMBLY EXAMPLE AND HYDRAULIC DIAGRAM

