

# DS3L

## 8 WATT SOLENOID OPERATED DIRECTIONAL CONTROL VALVE SERIES 10

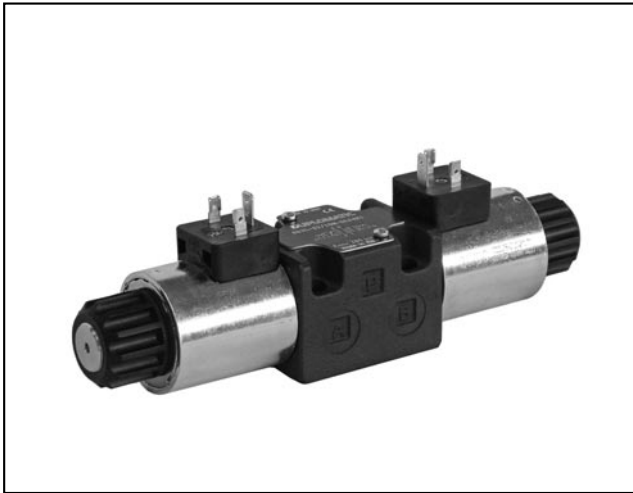

### SUBPLATE MOUNTING ISO 4401-03

**p** max **280** bar  
**Q** max **60** l/min

### MOUNTING INTERFACE

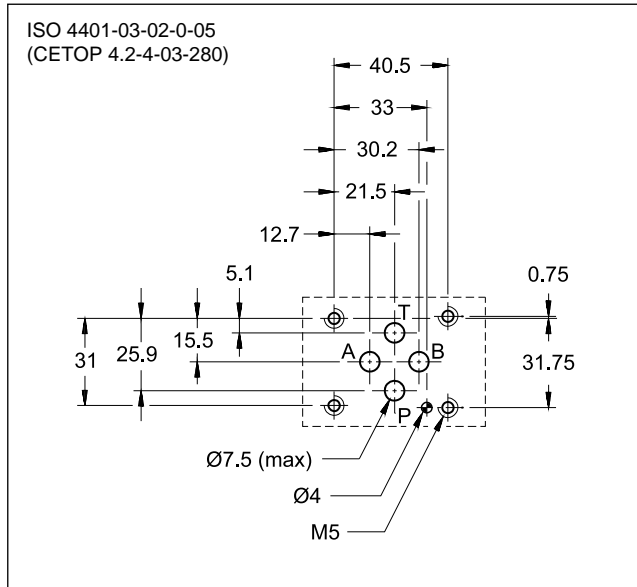

### OPERATING PRINCIPLE

- Low consumption (8 watt) direct operated directional solenoid valve for subplate mounting, with mounting surface according to ISO 4401-03 standards.
- The valve body is made with high strength iron castings provided with wide internal passages in order to minimize the flow pressure drop. Wet armature solenoids with interchangeable coils are used (for further information on solenoids see point 7).
- The valve is available in the 4-port version, 2 or 3 positions, and with the most common spools.
- It is available also with zinc-nickel surface treatment, that ensures a salt spray resistance up to 240 hours.
- Solenoids are 24 V power supply, DC.

### PERFORMANCES

(with mineral oil of viscosity of 36 cSt at 50°C)

Maximum operating pressure: - ports P - A - B - port T	bar	280 210
Maximum flow rate	l/min	60
Pressure drop $\Delta p$ -Q	see point 4	
Operating limits	see point 5	
Electrical features	see point 7	
Ambient temperature range	°C	-20 / +50
Fluid temperature range	°C	-20 / +80
Fluid viscosity range	cSt	10 ÷ 400
Fluid contamination degree	according to ISO 4406:1999 class 20/18/15	
Recommended viscosity	cSt	25
Mass: single solenoid valve double solenoid valve	kg	1,5 2

## 1 - IDENTIFICATION CODE

	D S 3 L - / 10 - DL24		
Solenoid operated directional control valve			Option: <b>/W7</b> = zinc-nickel surface treatment (see <b>NOTE</b> ) Omit if not required
ISO 4401-03 size			
Low energy consumption			Coil electrical connection: <b>K1</b> = plug for connector type EN 175301-803 (ex DIN 43650) ( <b>standard</b> ) <b>K12D5</b> = connection M12x1 5 pin (DESINA)
Spool type (see point 2):			
<b>S*</b> <b>TA</b> <b>SA*</b> <b>TB</b> <b>SB*</b> <b>RK</b>			DC power supply 24 V
Series No. _____ (the overall and mounting dimensions remain unchanged from 10 to 19)			
Seals: _____ <b>N</b> = NBR seals for mineral oil (standard) <b>V</b> = FPM seals for special fluids			<b>NOTE:</b> Standard surface treatment is phosphating black. On request we can supply these valves with zinc-nickel finishing, suitable to ensure a salt spray resistance up to 240 h (test operated according to UNI EN ISO 9227 standard and test evaluation operated according to UNI EN ISO 10289 standard). Add <b>/W7</b> at the end of the code.

## 2 - SPOOL TYPE

<p><b>Type S*:</b> 2 solenoids - 3 positions with spring centering</p> <p>S1 S2 S3 S4</p>	<p><b>Type SA*:</b> 1 solenoid side A 2 positions (central + external) with spring centering</p> <p>SA1 SA2 SA3 SA4</p>	<p><b>Type SB*:</b> 1 solenoid side B 2 positions (central + external) with spring centering</p> <p>SB1 SB2 SB3 SB4</p>
<p><b>Type RK:</b> 2 solenoids - 2 positions with mechanical retention</p> <p>RK</p>	<p><b>Type TA:</b> 1 solenoid side A 2 external positions with return spring</p> <p>TA</p>	<p><b>Type TB:</b> 1 solenoid side B 2 external positions with return spring</p> <p>TB</p>
<p><b>NOTE:</b> Others spools are available on request only.</p>		

## 3 - HYDRAULIC FLUIDS

Use mineral oil-based hydraulic fluids HL or HM type, according to ISO 6743-4. For these fluids, use NBR seals (code N). For fluids HFDR type (phosphate esters) use FPM seals (code V). For the use of other fluid types such as HFA, HFB, HFC, please consult our technical department.

Using fluids at temperatures higher than 80 °C causes a faster degradation of the fluid and of the seals characteristics. The fluid must be preserved in its physical and chemical characteristics.

### 4 - PRESSURE DROPS $\Delta P-Q$

(obtained with viscosity of 36 cSt at 50 °C)

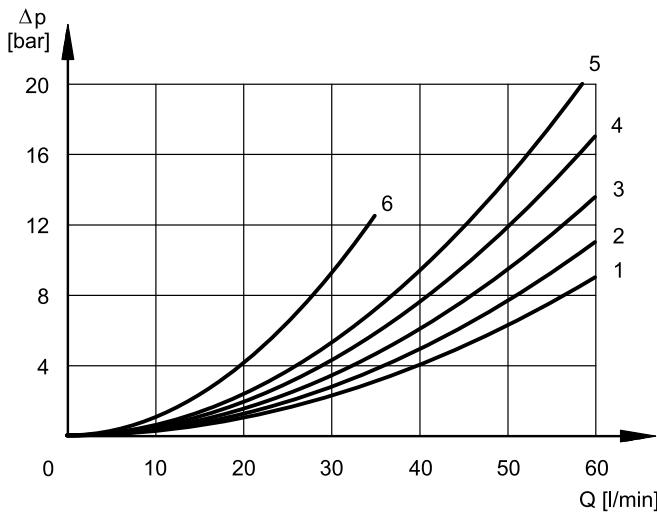

#### ENERGIZED VALVE

SPOOL	FLOW DIRECTIONS				
	P→A	P→B	A→T	B→T	P→T
	CURVES ON GRAPH				
S1, SA1, SB1	2	2	3	3	
S2, SA2, SB2	1	1	2	2	3
S3, SA3, SB3	3	3	1	1	
S4, SA4, SB4	5	5	5	5	
TA, TB	3	3	4	3	
RK	2	2	3	3	

#### DE-ENERGIZED VALVE

SPOOL	FLOW DIRECTIONS				
	P→A	P→B	A→T	B→T	P→T
	CURVES ON GRAPH				
S3, SA3, SB3			6	6	

### 5 - OPERATING LIMITS

The curves define the flow rate operating fields according to the valve pressure of the different versions.

The values have been obtained according to ISO 6403 norm with solenoids at rated temperature and supplied with voltage equal to 90% of the nominal voltage and connectors type EN 175301-803 supplied by a mechanical relay without any electronics (e.g. diode) in between.

The values have been obtained with mineral oil, viscosity 36 cSt, temperature 50 °C and filtration according to ISO 4406:1999 class 18/16/13.

**TA spools limits refer to the 4-port operation. The operating limits of a 4-port valve in 3-port operation or with port A or B plugged or without flow may reduce considerably.**

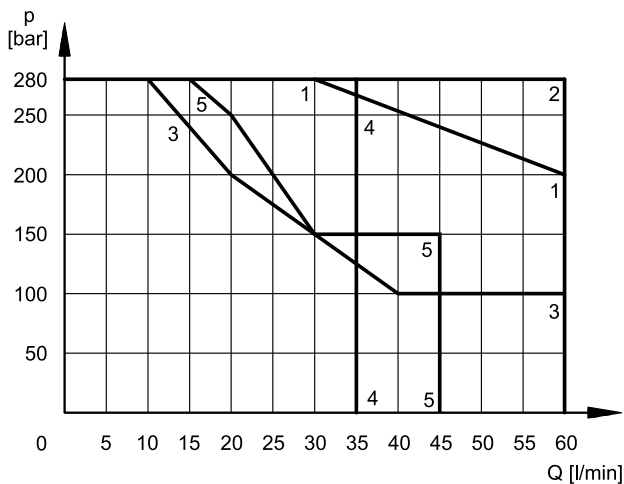

SPOOL	CURVE
S1	1
S2	2
S3	3
S4	4
TA	5
RK	2

### 6 - SWITCHING TIMES

The values indicated are obtained with spool S2, according to ISO 6403 standard, with mineral oil viscosity 36 cSt at 50 °C.

TIMES ( $\pm 10\%$ ) [ms]	
ENERGIZING	DE-ENERGIZING
100	20 ÷ 30

## 7 - ELECTRICAL FEATURES

### 7.1 - Solenoids

These are essentially made up of two parts: tube and coil. The tube is threaded into the valve body and includes the armature that moves immersed in oil, without wear. The inner part, in contact with the oil in the return line, ensures heat dissipation.

The coil is fastened to the tube by a threaded ring, and can be rotated 360°, to suit the available space.

<b>SUPPLY VOLTAGE FLUCTUATION</b>	± 10% V <sub>nom</sub>
<b>MAX SWITCH ON FREQUENCY</b>	7.000 ins/hr
<b>DUTY CYCLE</b>	100%
<b>ELECTROMAGNETIC COMPATIBILITY (EMC)</b>	In compliance with 2014/30/EU
<b>LOW VOLTAGE</b>	In compliance with 2014/35/EU
<b>CLASS OF PROTECTION</b> Atmospheric agents IEC 60529 Coil insulation (VDE 0580) Impregnation	IP 65 ( <b>NOTE</b> ) class H class F

**NOTE:** The IP65 protection degree is guaranteed only with the connector correctly connected and installed.

### 7.2 - Current and absorbed power for solenoid valve

The table shows current and power consumption values relevant to the 24 VDC coil.

#### Coil for direct current (values ± 10%)

	Nominal voltage [V]	Resistance at 20°C [Ω]	Current consumpt. [A]	Power consumpt [W]	Coil code	
					K1	K12D5
<b>DL24</b>	24	64.6	0.37	8.92	1903291	1903371

### 7.3 - Coils K12D5

Coils with K12D5 connection include the suppressor diode 1,5 KE 43CA, max. turn-off overload 50 V.

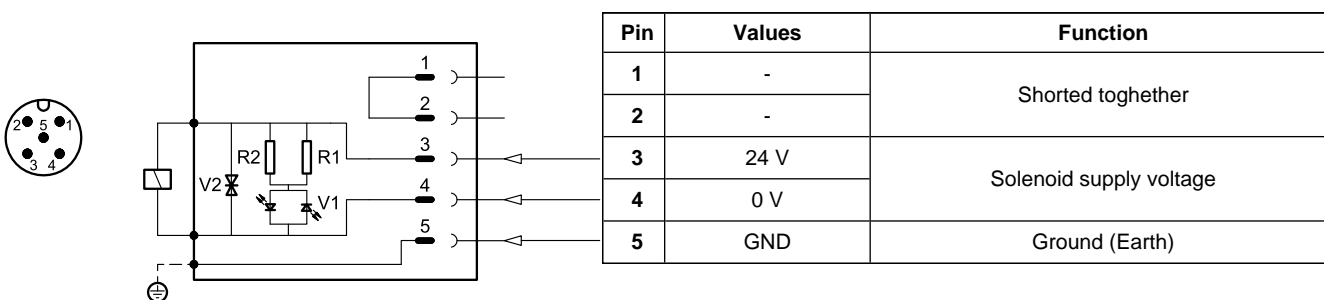

8 - OVERALL AND MOUNTING DIMENSIONS

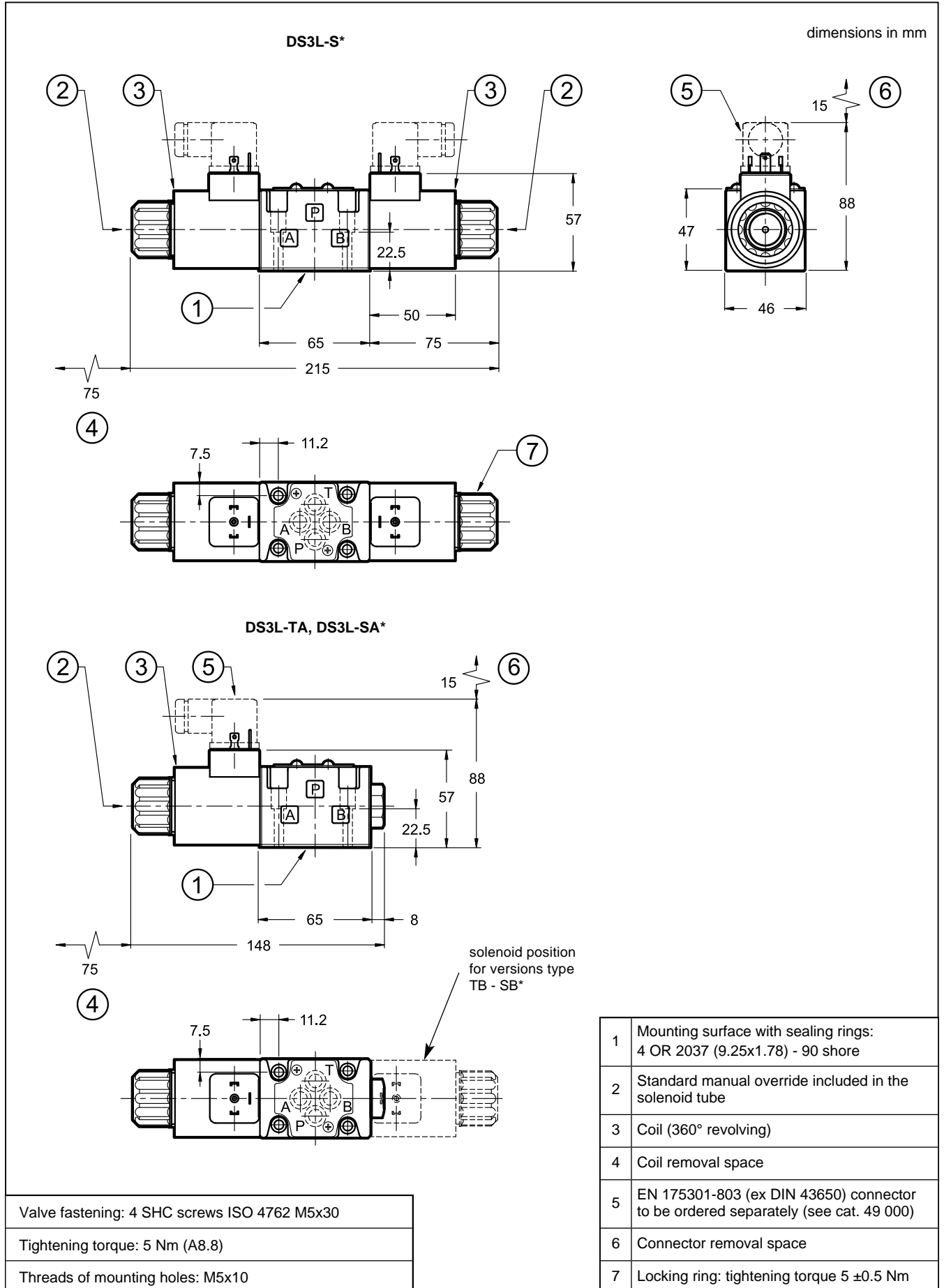

## 9 - INSTALLATION

Configurations with centering and return springs can be mounted in any position; type RK valves - without springs and with mechanical detent - must be mounted with the longitudinal axis horizontal.

Valve fitting takes place by means of screws or tie rods, fixing the valve on a lapped surface, with values of planarity and smoothness that are equal to or better than those indicated in the drawing.

If the minimum values of planarity or smoothness are not met, fluid leakages between valve and mounting surface can easily occur.

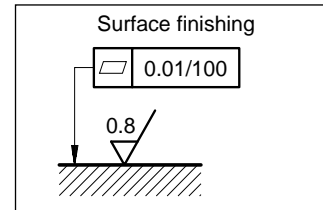

## 10 - ELECTRIC CONNECTIONS

connection for EN 175301-803  
(ex DIN 43650) connector  
code **K1 (standard)**

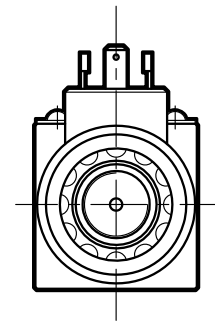
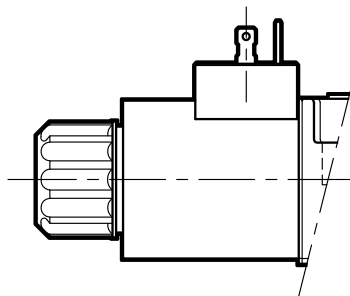

connection for M12x1 5 pin connector  
DESINA type  
code **K12D5**

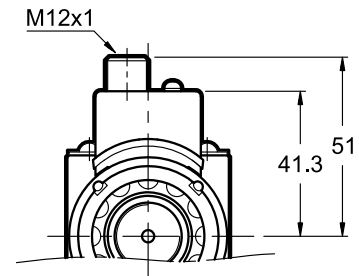
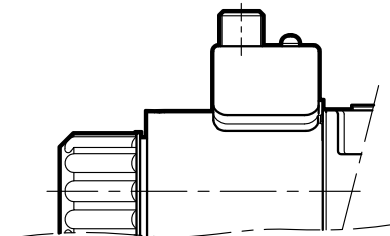

## 11 - ELECTRIC CONNECTORS

Connectors must be ordered separately. See catalogue 49 000. We do not supply connectors for K12D5 connection.

## 12 - SPARE PARTS

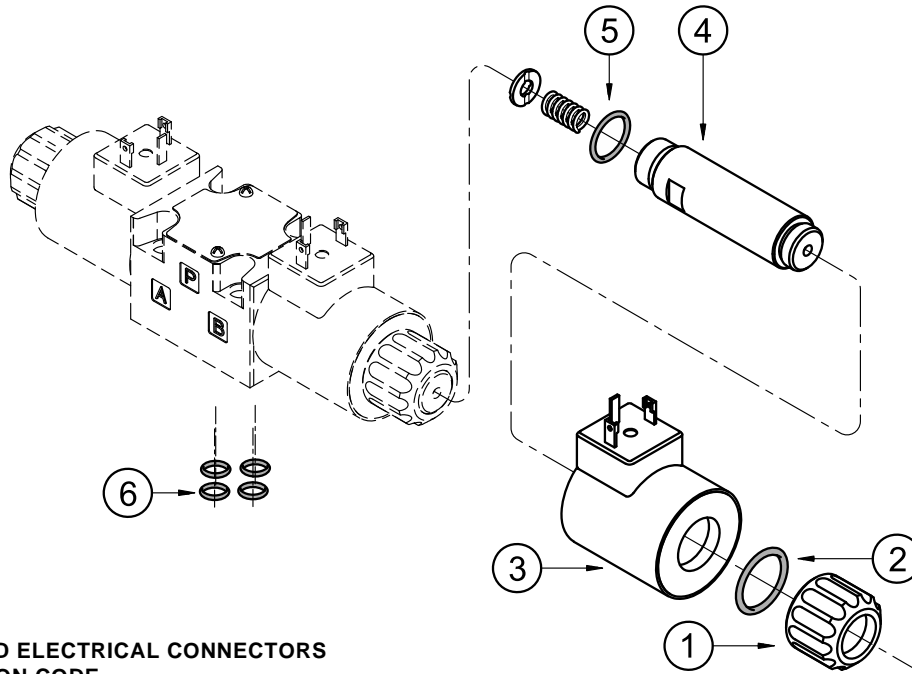

### DC COILS AND ELECTRICAL CONNECTORS IDENTIFICATION CODE

**C 22L3B - DL24 / 11**

Supply voltage

Series no.

Coil electrical connection  
(see point 11):  
**K1** = plug for connector  
EN 175301-803 (ex DIN 43650)  
**K12D5** = connection M12x1 5 pin  
(DESINA)

1	Coil locking ring with seal included cod. 0119412 Tightening torque 5 ±0.5 Nm
2	ORM type 0220-20 (22x2) - 70 Shore
3	Coil (see identification code on the side)
4	Solenoid tube for standard version: TDM22-DS3L/10N (NBR seals) TDM22-DS3L/10V (FPM seals) <b>NOTE:</b> OR n°5 included
5	OR type 2062 (15.6x1.78) - 70 Shore
6	N. 4 OR type 2037 (9.25x1.78) - 90 Shore

### SEALS KIT

The codes include the O-Ring n° 2, 5 and 6.

**Cod. 1985406** NBR seals  
**Cod. 1985410** FPM (viton) seals

## 13 - SUBPLATES

(see catalogue 51 000)

Type PMMD-AI3G with rear ports 3/8" BSP

Type PMMD-AL3G with side ports 3/8" BSP



**DS3L**  
SERIES 10

**DUPLOMATIC**  
MOTION SOLUTIONS  
*a member of **DAIKIN** group*

**DUPLOMATIC MS Spa**

via Mario Re Depaolini, 24 | 20015 Parabiago (MI) | Italy

T +39 0331 895111 | E vendite.ita@duplomatic.com | sales.exp@duplomatic.com

duplomaticmotionsolutions.com