



GPA*

EXTERNAL GEAR PUMPS

SERIES 10

OPERATING PRINCIPLE

- The GPA* pumps are external gear pumps with fixed displacement and axial clearance compensation.
- They give high volumetric efficiency even with high operating pressures, a low noise level, and they have a high endurance thanks to the balancing system of the loads on the guide bushings.
- They are available with four-holes european flange and tapered shaft end 1:8 or with SAEJ 744 flange and splined shaft. Clockwise or anticlockwise rotation.
- They are divided into three size groups, with displacements of up to 7.5, 31.7 and 61 cm³/rev respectively, and with operating pressures of up to 260 bar continuous pressure.
- They are available as single, tandem or multiple pumps.

TECHNICAL SPECIFICATIONS

PUMP		GPA1	GPA2	GPA3
Displacement range	cm ³ /rev	1 ÷ 7.5	4.5 ÷ 31.7	22 ÷ 61
Continuous operating pressure (NOTE)	bar	up to 260	up to 260	up to 250
Max rotation speed (NOTE)	rpm	4000	4000	3000
Rotation direction		clockwise or anticlockwise		
Loads on the shaft		radial and axial load are not allowed		
Max torque applicable to the shaft		see point 9.1		
Hydraulic connections		german flange BSPP threaded	european flange BSPP threaded	
Type of mounting		4-holes flange - rectangular type / SAE flange		
Mass	kg	1.3 ÷ 1.9	3.3 ÷ 4.6	5.8 ÷ 8.8

NOTE: See details for each displacement at point 2.

Ambient temperature range	°C	-20 / +50
Fluid temperature range	°C	-25 / +80
Fluid viscosity range		see point 5.2
Fluid contamination degree		see point 5.3
Recommended viscosity	cSt	10 ÷ 750

HYDRAULIC SYMBOL

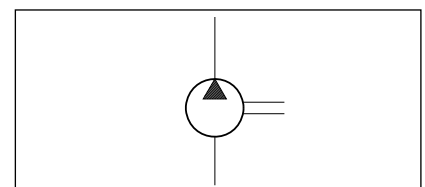

1 - IDENTIFICATION CODE

1.1 - Single pumps

	GP	A	-		-		-		S	/	10	N
--	-----------	----------	---	--	---	--	---	--	----------	---	-----------	----------

External gear pump —

Aluminium body —

Pump size: _____
1 = from 1 to 7.5 cm³/rev
2 = from 4.5 to 31.7 cm³/rev
3 = from 22 to 61 cm³/rev

Rotation (seen from the shaft side) —
R = clockwise (**standard**)
L = anticlockwise

Displacement _____
 (see table 2 - Performances)

NBR seals for mineral oils

Series No. (overall and mounting dimensions do not change from 10 to 19)

Side ports

Hydraulic connections: see table 1.5 and point 7

Mounting flange and shaft end:
 European flange 4-holes and tapered shaft-end 1:8
E10T1 = for GPA1 pumps
E12T11 = for GPA1 pumps, only sizes 025, 031, 038, 047, 053 and 075 (**NOTE**).
E20T2 = for GPA2 pumps
E30T3 = for GPA3 pumps
 SAE J744 flange 2-holes and splined shaft-end
A09T = for GPA2 pumps
B13T = for GPA3 pumps

NOTE: The E12T11 mounting is interchangeable with that of GP1-**97, cat. 11 100. See point 6.2.

1.2 - Tandem and multiple pumps

	+	A	-		-		S	/	10	N
--	---	----------	---	--	---	--	----------	---	-----------	----------

Front pump code —

Aluminium body —

Pump size: _____
availability according to the table below.
1 = from 1 to 7.5 cm³/rev
2 = from 4.5 to 31.7 cm³/rev
3 = from 22 to 61 cm³/rev

front pump	rear pump size		
	1	2	3
GPA1	■	-	-
GPA2	■	■	-
GPA3	-	■	■

NBR seals for mineral oils

Series No. (overall and mounting dimensions do not change from 10 to 19).

Side ports

Hydraulic connections: see table 1.5 and point 7

Displacement _____
 (see table 2 - Performances)

1.3 - Codes examples

Single pump: GPA2-R113-E20T2-FE3/2S/10N

Assembled pump: double pump GPA2-R082-E20T2-FE2/2S/10N + A2-065-FE2/2S/10N

multiple pump GPA2-R113-E20T2-FE3/2S/10N + A1-047-FG2/2S/10N

1.4 - Loose intermediate pumps

Intermediate pumps are available loose only. See point. 9.2.



1.5 - Available hydraulic connections

pump	ports type	hydraulic connection code suction / delivery	inlet	outlet	available for displacements
GPA1	German flanged	FG2/2	Ø13 mm	Ø13 mm	all
	BSPP threaded (ISO 228)	B15/15	3/8" BSPP	3/8" BSPP	010 to 038
		B2/15	1/2" BSPP	3/8" BSPP	047 to 075
GPA2	European flanged	FE2/2	Ø13 mm	Ø13 mm	045 to 082
		FE3/2	Ø20 mm	Ø13 mm	113 to 317
	BSPP threaded (ISO 228)	B2/2	1/2" BSPP	1/2" BSPP	045 to 113
		B3/2	3/4" BSPP	1/2" BSPP	146 to 317
GPA3	European flanged	FE4/3	Ø27 mm	Ø20 mm	220 to 520
		FE5/4	Ø33 mm	Ø27 mm	610
	BSPP threaded (ISO 228)	B4/3	1" BSPP	3/4" BSPP	220 to 520
		B5/4	1 1/4" BSPP	1" BSPP	610

2 - PERFORMANCE RATINGS

(values obtained with mineral oil with viscosity of 46 cSt at 40 °C)

PUMP	NOMINAL SIZE	DISPLACEMENT [cm ³ /rev]	FLOW RATE at 1500 rpm [l/min]	MAX PRESSURE at 1500 rpm [bar]			SPEED [rpm]	
				continuous operating (p1)	intermittent (p2)	peak (p3)	max	min
GPA1	010	1	1.5	250	270	290	4000	650
	015	1.5	2.2	260	280	300		
	019	1.9	2.9					
	025	2.5	3.8					
	031	3.1	4.7					
	038	3.8	5.7	240	260	280		
	047	4.7	7.1					
	053	5.3	8.0					
		063	6.3	9.5	230	250	270	3500
	075	7.5	11.3	180	200	220		
GPA2	045	4.5	6.8	260	290	310	4000	600
	065	6.5	9.7					
	082	8.2	12.3					
	113	11.3	16.9					
	146	14.6	21.9				3500	
	169	16.9	25.4	3200				
		201	20.1	30.2	250	280	300	500
		220	22	33	250	280	300	
		252	25.2	37.8	210	240	260	
		280	28	42	200	230	250	
		317	31.7	47.6	180	210	230	

PUMP	NOMINAL SIZE	DISPLACEMENT [cm ³ /rev]	FLOW RATE at 1500 rpm [l/min]	MAX PRESSURE at 1500 rpm [bar]			SPEED [rpm]	
				continuous operating (p1)	intermittent (p2)	peak (p3)	max	min
GPA3	220	22	33	250	270	280	3000	500
	270	27	40.5					
	330	33	49.5	240	260	270		
	390	39	58.5					
	440	44	66	230	250	260		
	480	48	72	210	230	240	2500	
	520	52	78					
	610	61	91.5	190	210	220		

2.1 - Pressures definitions

GPA* pumps can operate at the max continuous pressure P1 at the delivery, with no pressure on suction.

The max time given for the peak (P3) and its extinction is 1 second as it is intended as the intervention time of the pressure relief valve of the system.

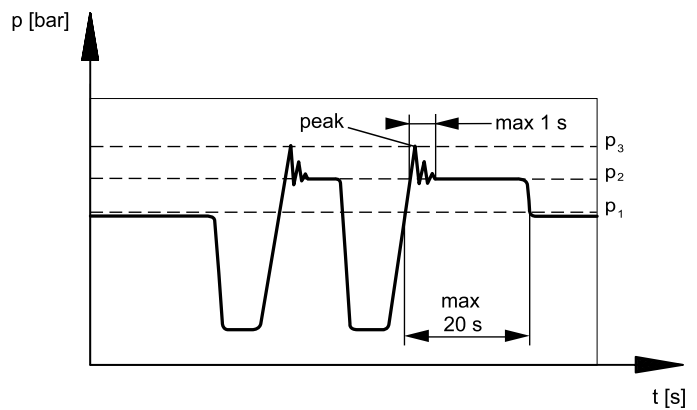

- p_1 Max. continuous pressure (duty cycle 100%)
- p_2 Max. intermittent pressure for a working cycle of 60 sec.
- p_3 Max. pressure peak

3 - CURVES AND CHARACTERISTIC DATA

(values obtained with mineral oil with viscosity of 46 cSt at 40 °C, at 1500 rpm)

Absorbed powers are theoretical, taking into account average efficiencies.

3.1 - GPA1 flow rate / pressure curve

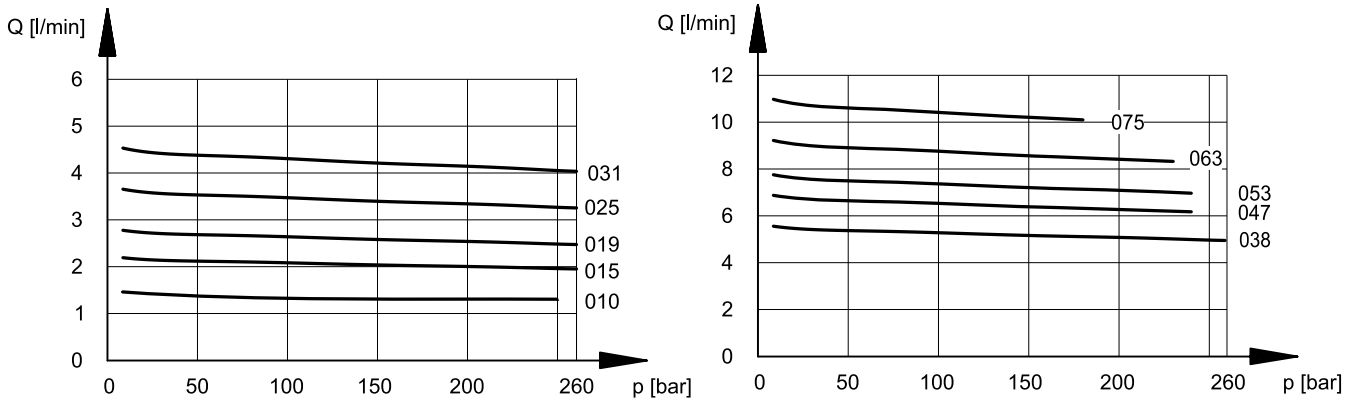

3.2 - GPA1 absorbed power

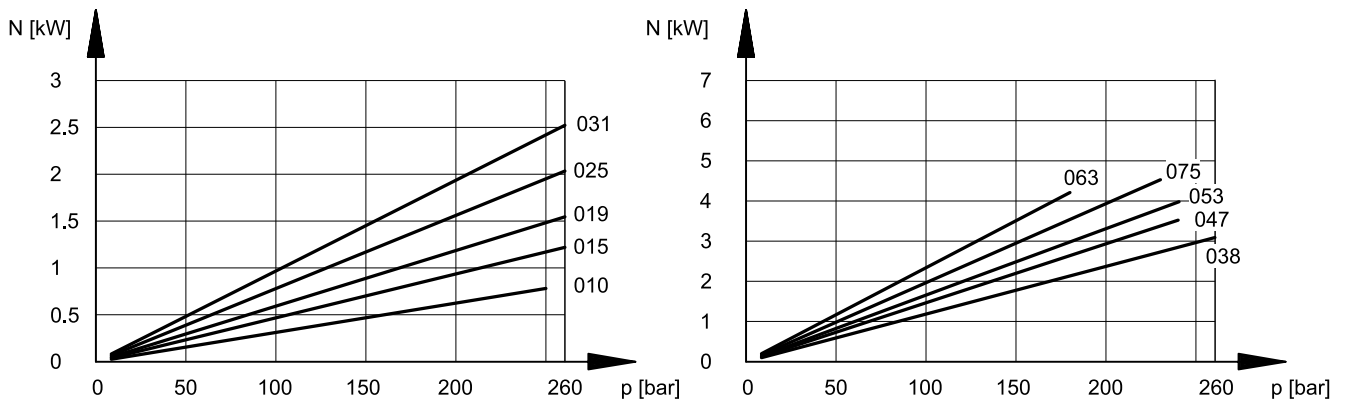

3.3 - GPA1 volumetric efficiency

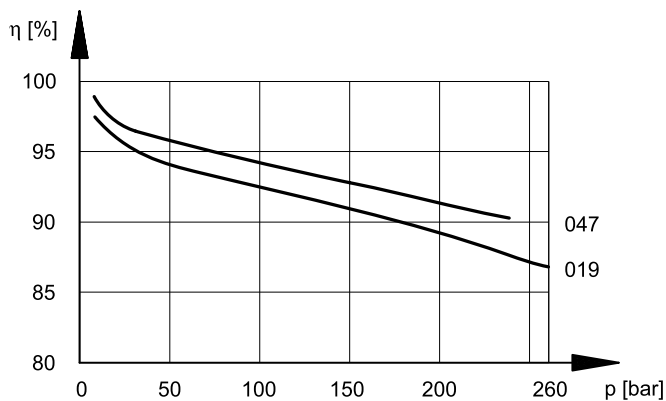



3.4 - GPA2 flow rate / pressure curve

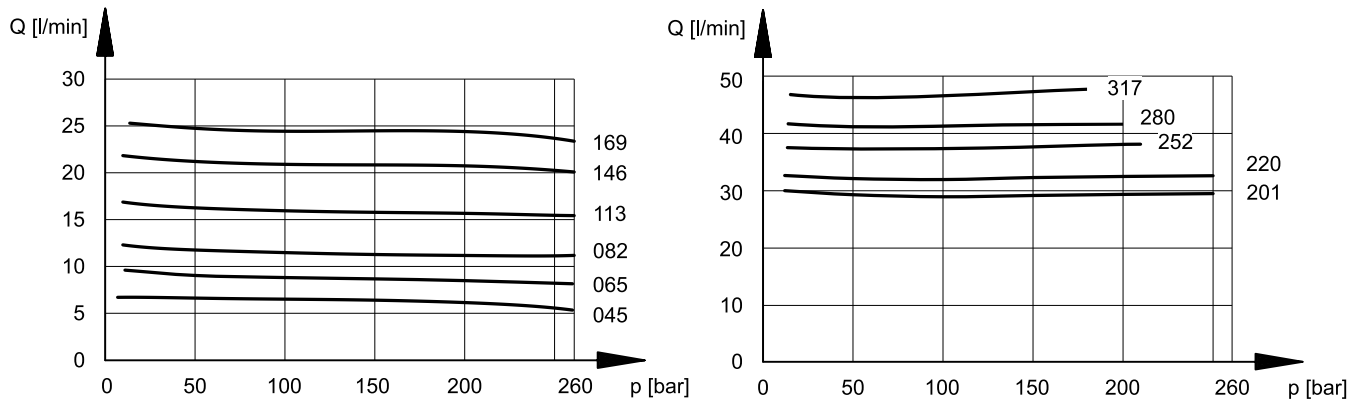

3.5 - GPA2 absorbed power

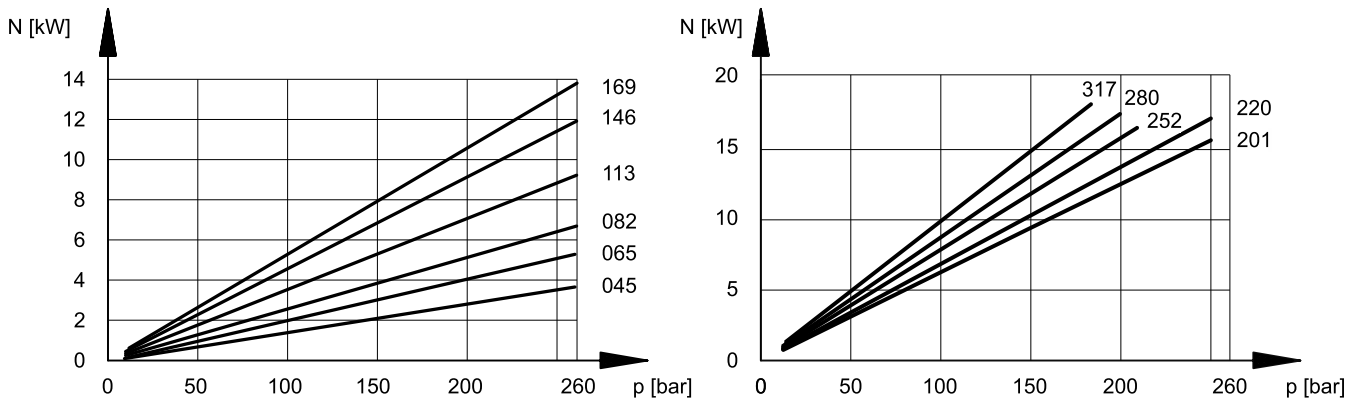

3.6 - GPA2 volumetric efficiency

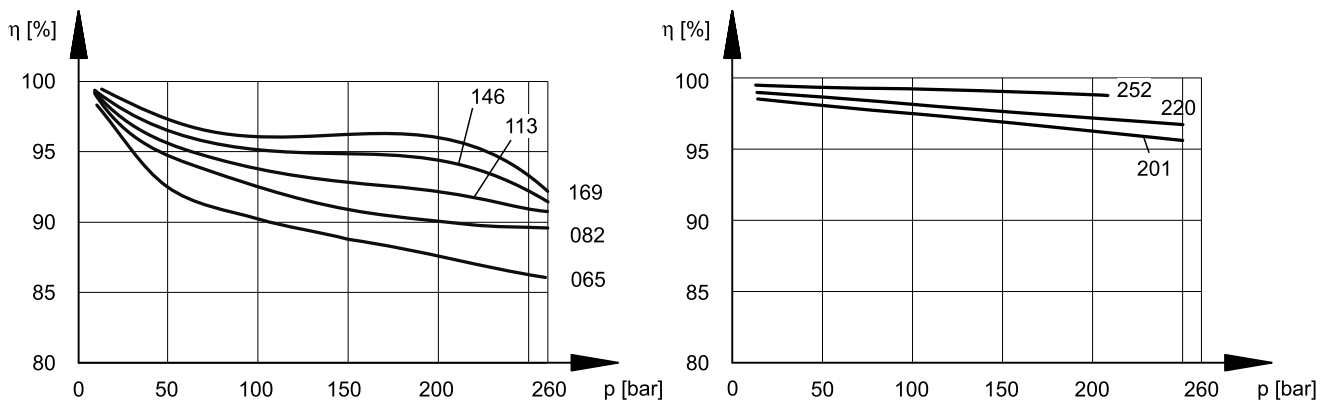

3.7 - GPA3 flow rate / pressure curve

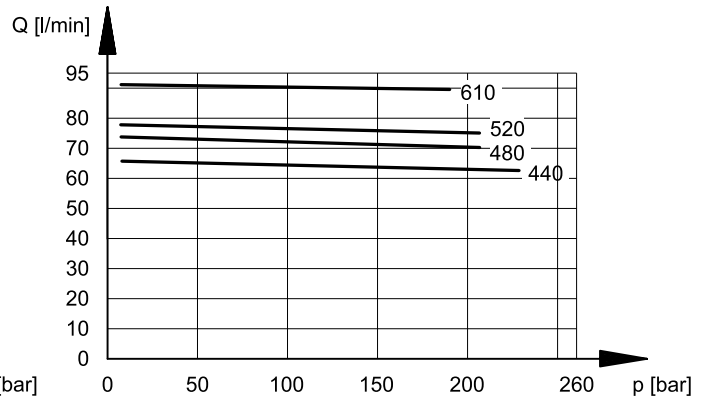
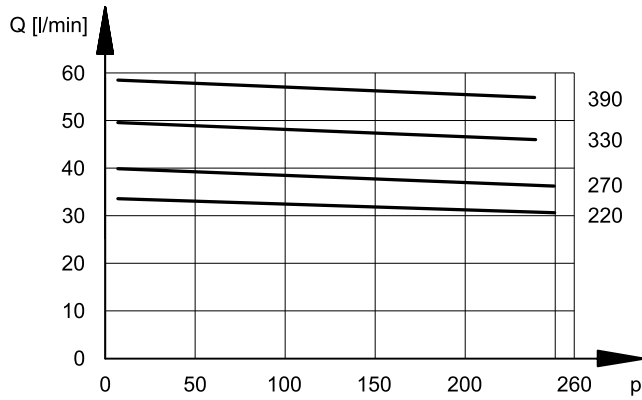

3.8 - GPA3 absorbed power

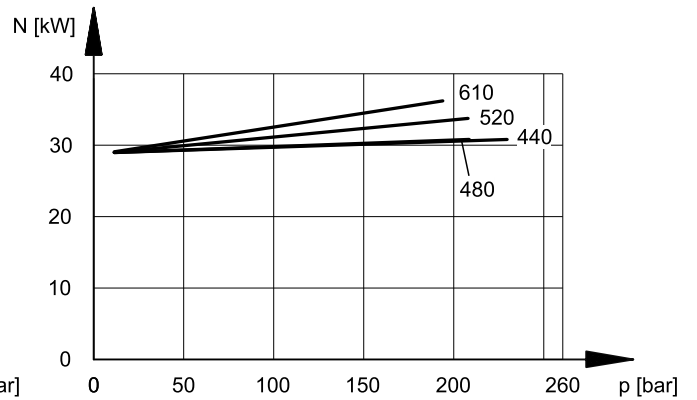
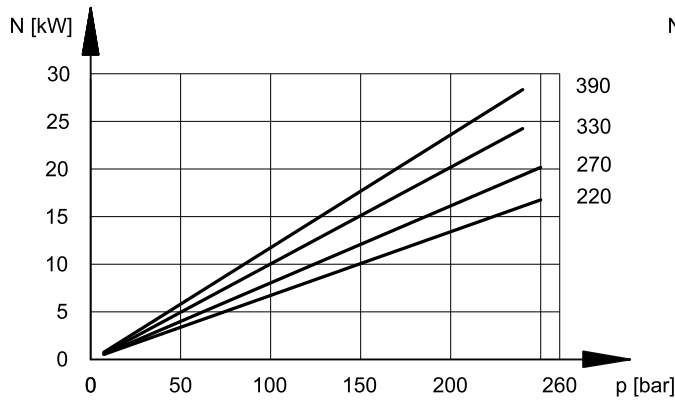

3.9 - GPA3 volumetric efficiency

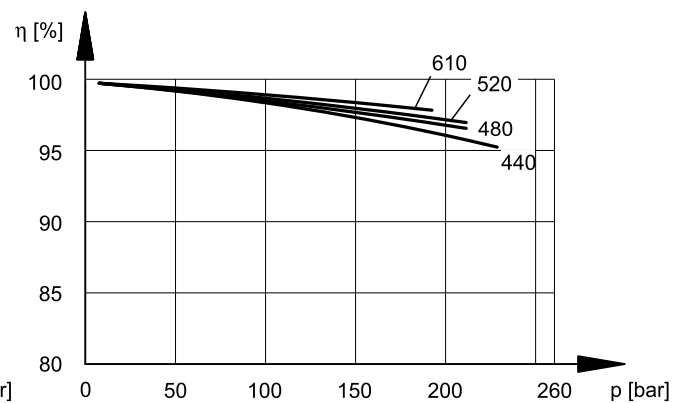
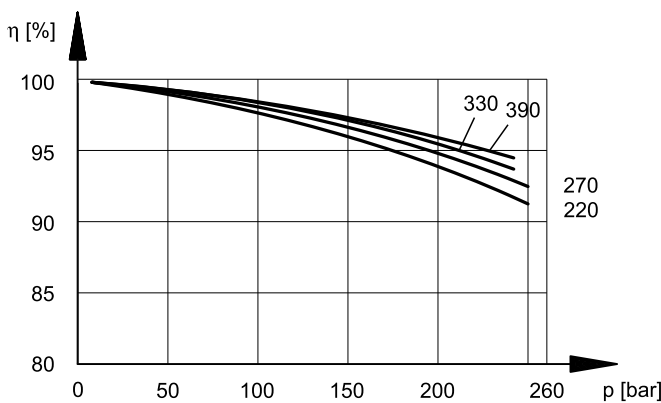



4 - NOISE LEVEL

The data shown in the diagrams were noted with pump rotation speed = 1500 rpm.

Noise pressure levels were measured in a semi-anechoic room, at an axial distance of 1 m from the pump.

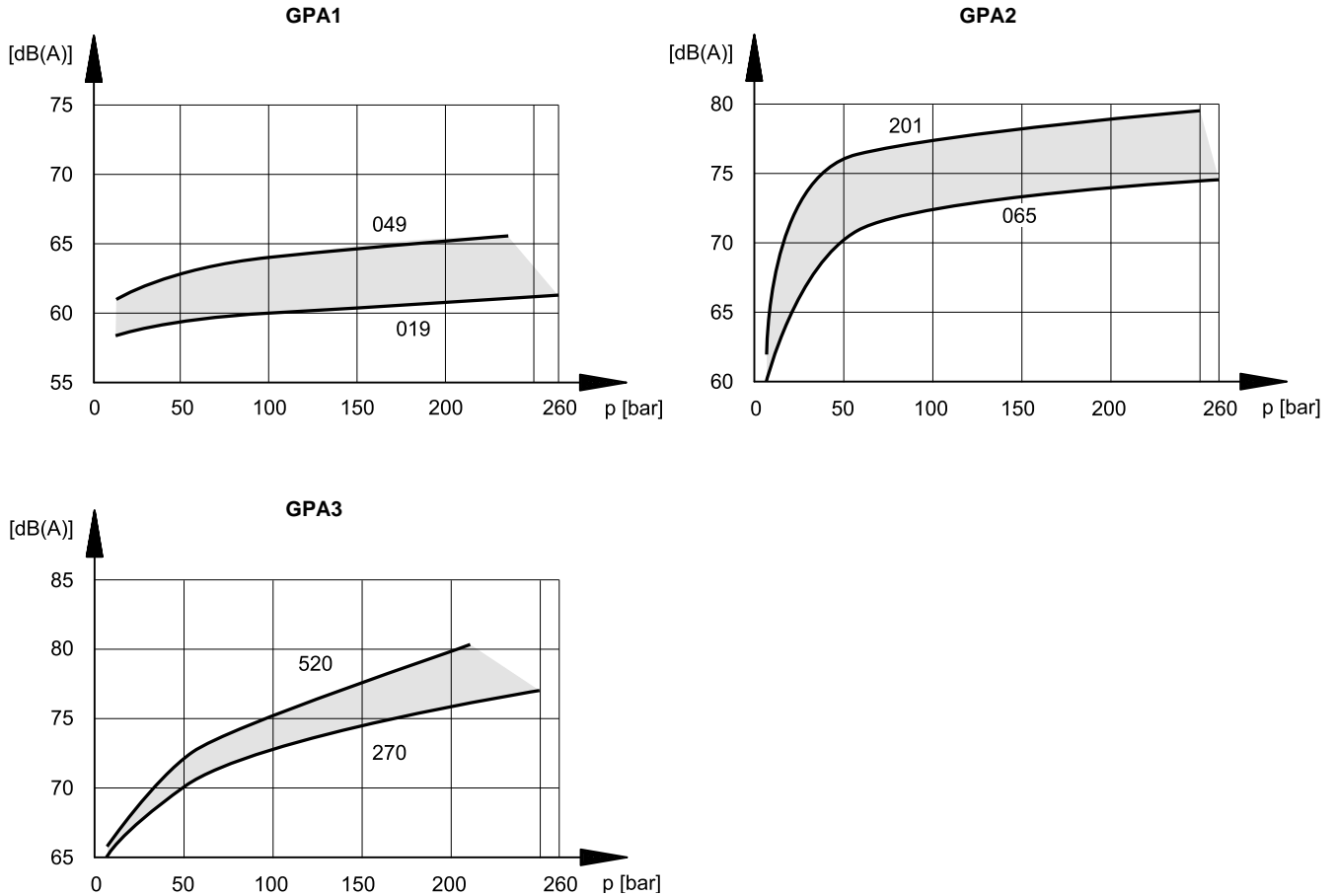

5 - HYDRAULIC FLUID

5.1 - Type of fluid

Use mineral oil based hydraulic fluids with anti-foam and antioxidant additives, in conformity with the requisites of the following standards:
FZG test - 11th stage; DIN 51525; VDMA 24317

For use with other types of fluid (water glycol, phosphate esters and others), consult our technical dept. Operation with fluid at a temperature greater than 80°C causes a premature deterioration of the fluid quality and of the seals. The physical and chemical properties of the fluid must be maintained.

5.2 - Fluid viscosity

The operating fluid viscosity must be within the following range:

ideal viscosity	10 ÷ 100 cSt	
recommended viscosity	up to 750 cSt	
maximum viscosity	1000 cSt	(limited to only the start-up phase of the pump)

5.3 - Degree of fluid contamination

Working pressure bar (psi)	$\Delta p < 140$ (2030)	140 (2030) $< \Delta p < 210$ (3040)	$\Delta p > 210$ (3040)
Class contamination NAS 1638	10	9	8
Class contamination ISO 4406:1999	21/19/16	20/18/15	19/17/14

If there is a filter installed on the suction line, be sure that the pressure at the pump inlet must be 0.7 ÷ 3 bar. The suction filter must be equipped with a by-pass valve and, if possible, with a clogging indicator.

6 - OVERALL AND MOUNTING DIMENSIONS

NOTE: All the pumps here represented are clockwise rotating. Oil ports are reversed on pumps with anticlockwise rotation.

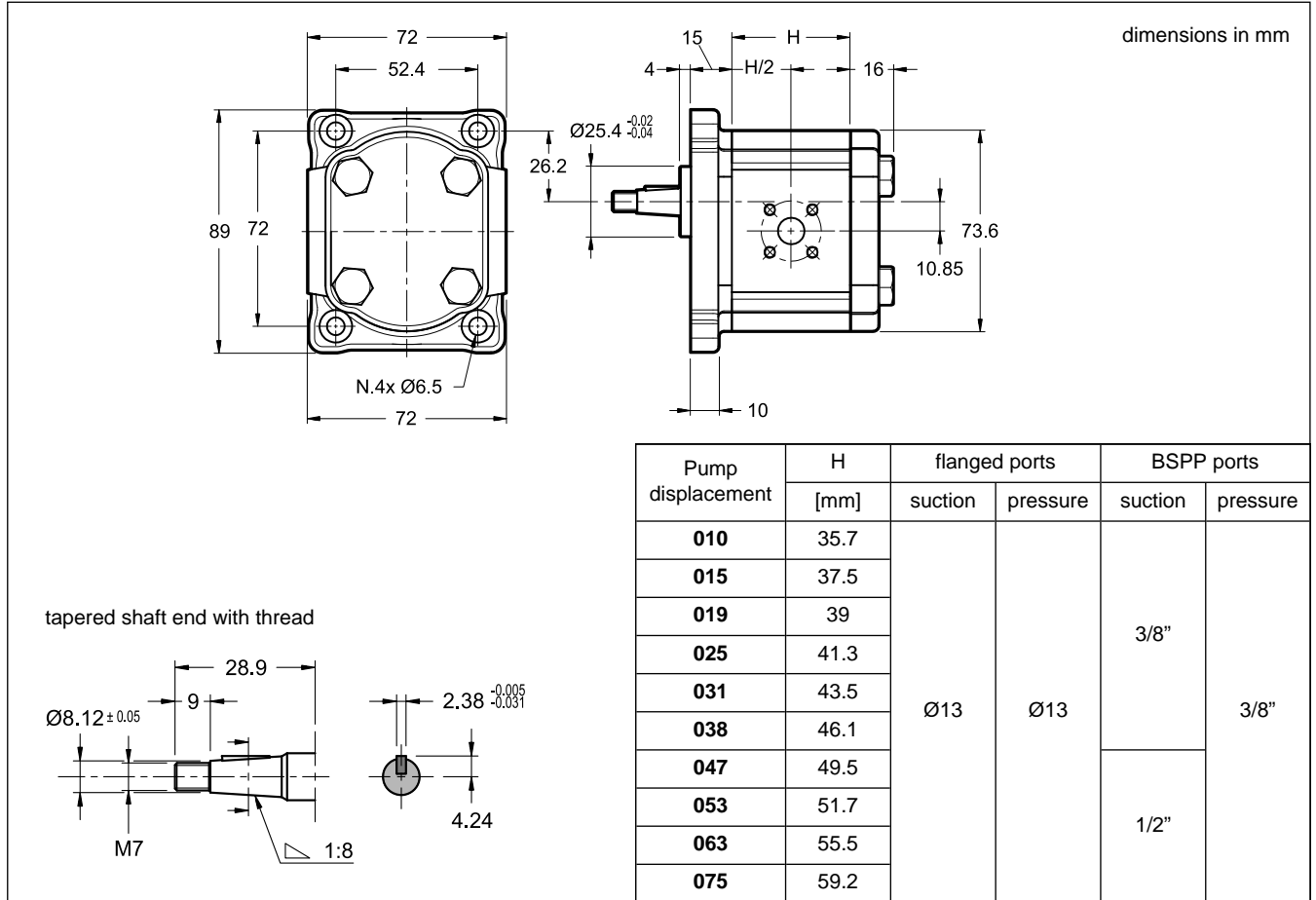
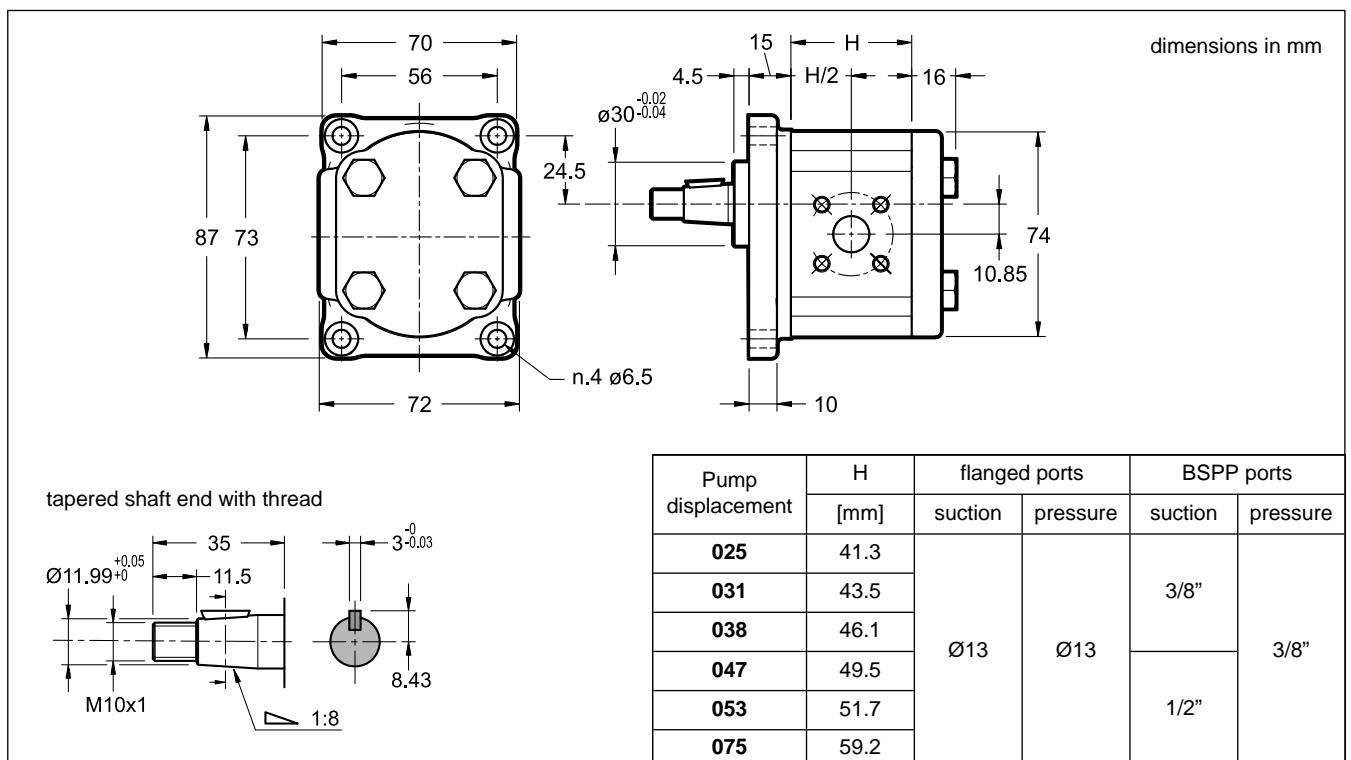
6.1 - GPA1--E10T1 (European flange mounting)**

6.2 - GPA1--E12T11 (European flange mounting)**

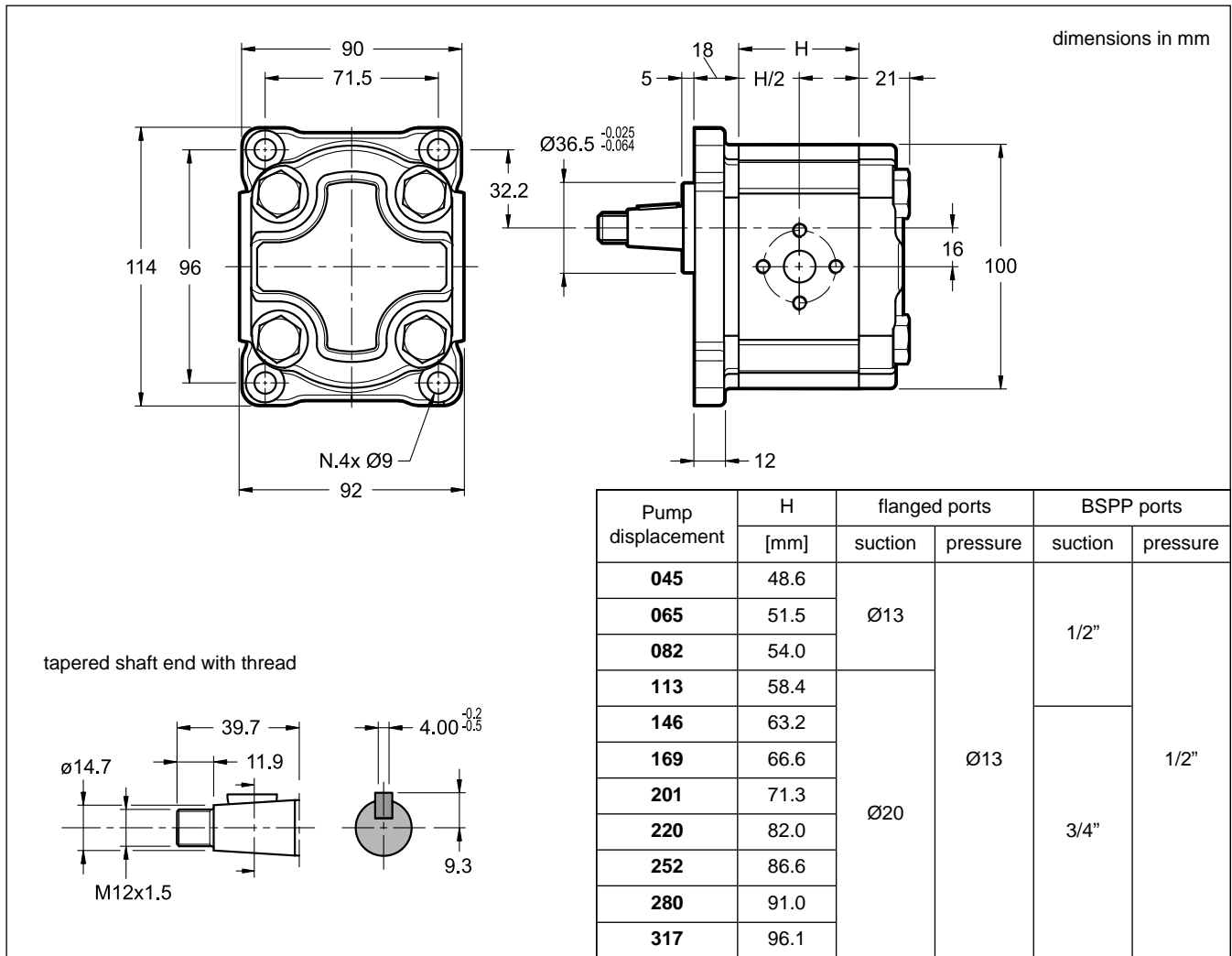
6.3 - GPA2- E20T2 (European flange mounting)**

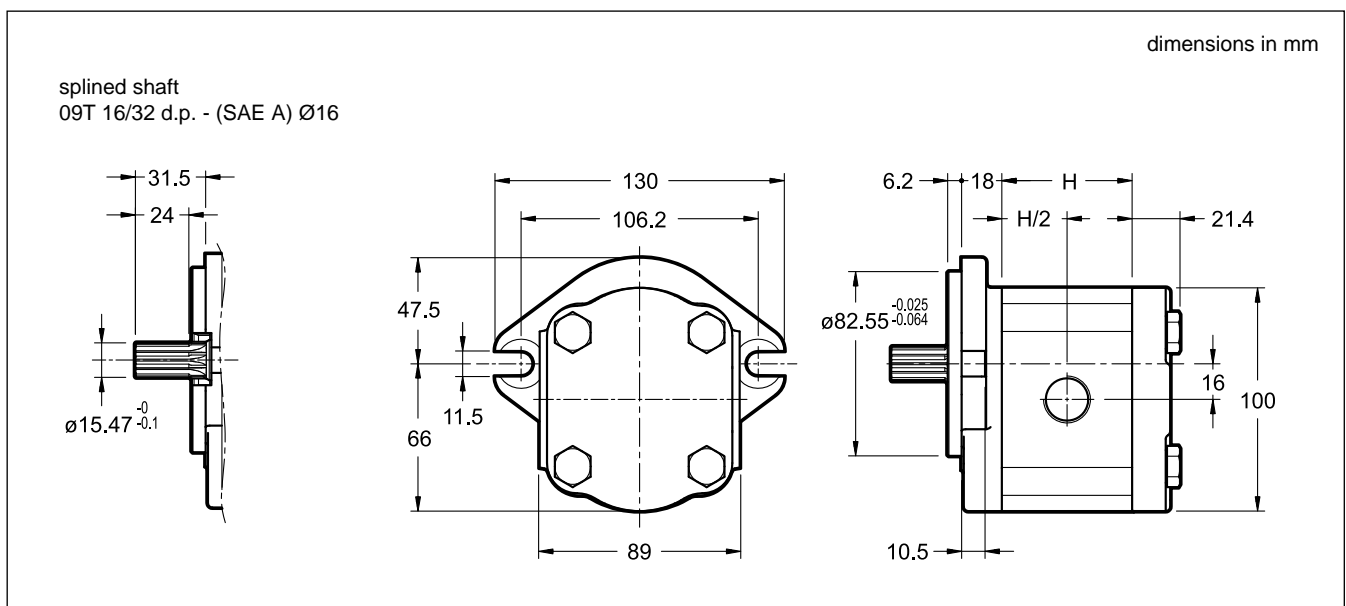

6.4 - GPA2- A09T (SAE A J744 flange mounting)**

Please refer to the table in the previous point for available displacement, oil ports and H dimensions.

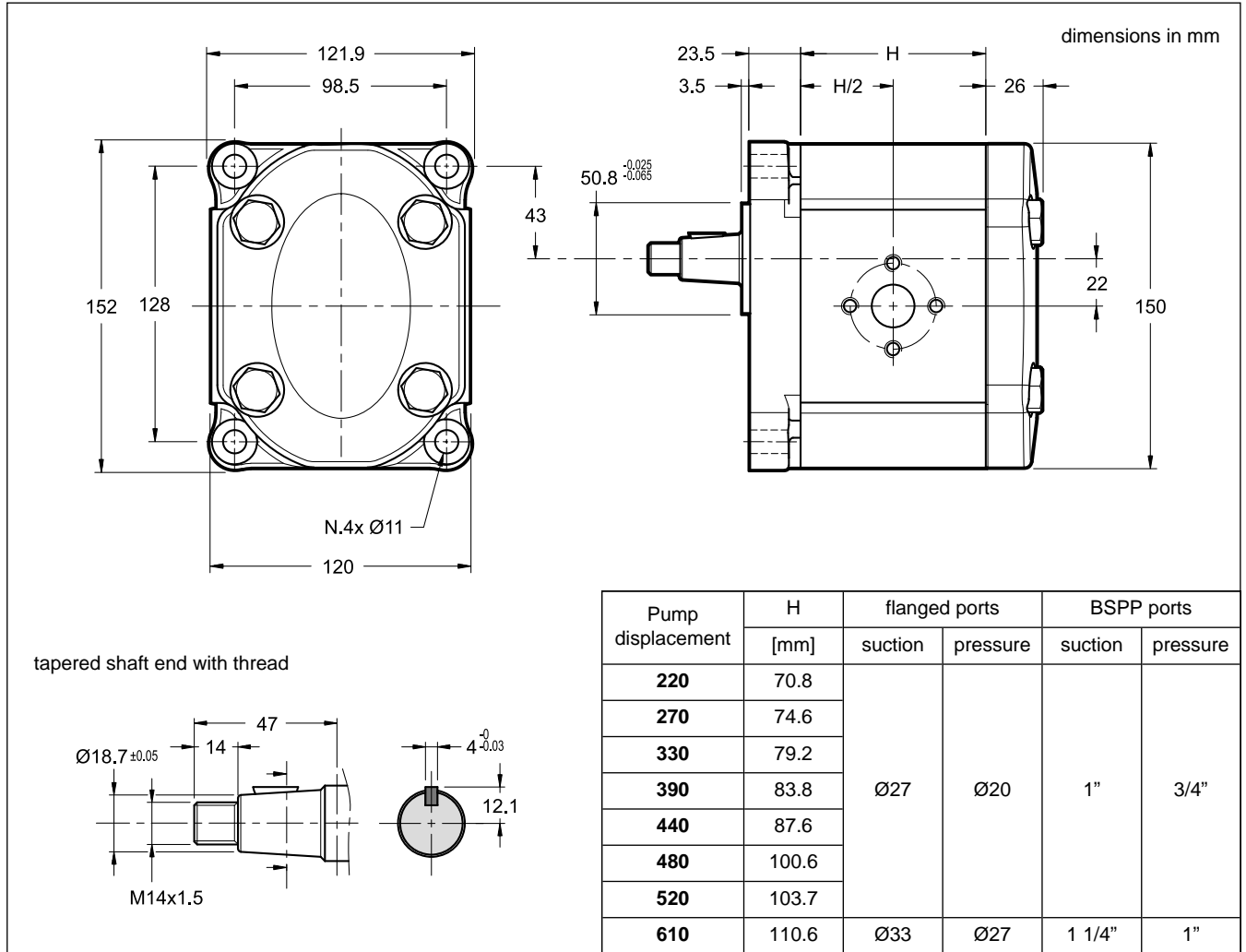

6.5 - GPA3--E30T3 (European flange mounting)**

6.6 - GPA3--B13T (SAE B J744 flange mounting)**

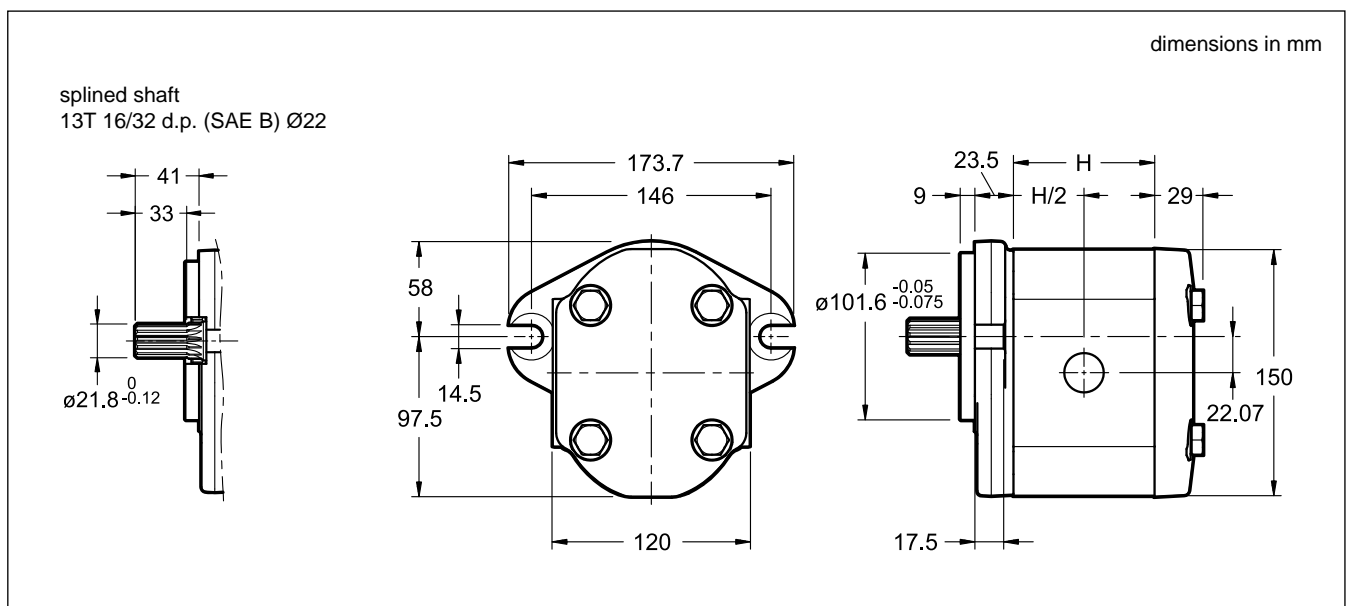
Please refer to the table in the previous point for available displacement, oil ports and dimensions.



7 - HYDRAULIC CONNECTION PORTS

7.1 - German flanged (FG)

	Code	Dimensions [mm]			Tightening torque [Nm]	
		A	B	C	low pressure	high pressure
	FG2	Ø13	30	M6	8	8

7.2 - European flanged (FE)

	Code	Dimensions [mm]			Tightening torque [Nm]	
		A	B	C	low pressure	high pressure
	FE2	Ø13	30	M6	8	8
	FE3	Ø20	40	M8	15	15
	FE4	Ø27	51	M10	20	30
FE5	Ø33	62	M12	25	50	

7.3 - BSPP threaded (B)

	Code	Dimensions [mm]			Tightening torque [Nm]	
		A	B	C	low pressure	high pressure
	B1	3/8"	15	12	15	25
	B2	1/2"	19	14	20	50
	B3	3/4"	24	18	30	80
	B4	1"	30	22	50	130
B5	1 1/4"	39	22	60	170	

BSPP ports version

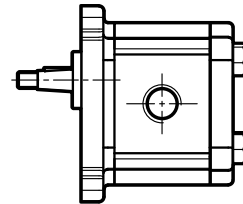

8 - TANDEM AND MULTIPLE PUMPS OVERALL DIMENSIONS

Dimensions below are for standard pumps. Please consult our Technical Dept. for different configurations, for common inlet and for overall dimensions of groups composed by three or more pumps.

Sum the values for flange, bodies and cover of the desired sizes and then add the coupling from the dedicated table to obtain the pump length. Missing dimensions can be taken from the overall dimensions drawings of the single pumps.

dimensions in mm

		C (coupling)		
front pump	rear pump size			
	1	2	3	
GPA1	5	-	-	
GPA2	33	7	-	
GPA3	-	41	21	

Pump	Displacement	A (flange)	B (body)	D (cover)
GPA1	010	15	35.7	16
	015		37.5	
	019		39	
	025		41.3	
	031		43.5	
	038		46.1	
	047		49.5	
	053		51.7	
	063		55.5	
GPA2	075	18	59.2	25
	045		48.6	
	065		51.5	
	082		54.0	
	113		58.4	
	146		63.2	
	169		66.6	
	201		71.3	
	220		82.0	
	252		86.6	
GPA3	280	23.5	91.0	26
	317		96.1	
	220		70.8	
	270		74.6	
	330		79.2	
	390		83.8	
	440		87.6	
480	100.6			
520	103.7			
610	110.6			

9 - MULTIPLE PUMPS

It is possible to create multi-flow groups with independent hydraulic circuits coupling several pumps together. The following conditions must be taken into account while sizing multiple pumps :

- Assembly can take place between pumps of the same group or as in table at point 1.2, in decreasing order of displacement.
- The max. rotation speed is determined by the pump with the lowest speed.
- The values of the max. applicable torque can not be exceeded.

9.1 - Maximum applicable torque

The input torque (M) is given for each pump by the following ratio:

$$M = \frac{9550 \cdot N}{n} = [\text{Nm}]$$

where the absorbed power (N) is given by:

$$N = \frac{Q \cdot \Delta p}{600 \cdot \eta_{\text{tot}}} = [\text{kW}]$$

n = rotation speed [rpm]

Q = flow rate [l/min]

Δp = differential pressure between the pump suction and delivery [bar]

η_{tot} = total efficiency

If several pumps are coupled, the torque of each single pump has to be added to the torque of subsequent pumps when they are loaded simultaneously.

The obtained torque value for each pump has to be lower than the value specified in the table below.

If the obtained torque values are higher than those stated in the table, reduce the working pressure value or replace the overloaded pump with a pump suitable to bear the required torque.

	MAX APPLICABLE TORQUE [Nm]	
	Front pump	Intermediate / rear pump
GPA1*-E10T1	20	30
GPA1*-E12T11	60	30
GPA2*-E	140	100
GPA3*-E	280	180
GPA2*-A	100	100
GPA3*-A	330	180

9.2 - Intermediate pumps identification code

Intermediate pumps can be purchased loose to create tandem pumps or multiple pumps in the same group size, or as spare parts.

See document *MI 11 102_E_00 Overall Instruction*. Refer to the code at point 1.2 to buy assembled pump groups.

A - - **S / 10 N**

Aluminium body

Pump size:
1 = from 1 to 7.5 cm³/rev
2 = from 4.5 to 31.7 cm³/rev
3 = from 22 to 61 cm³/rev

Rotation (seen from the shaft side)
R = clockwise (**standard**)
L = anticlockwise

Displacement
 (see table 2 - Performances)

NBR seals for mineral oils

Series No. (overall and mounting dimensions do not change from 10 to 19)

Side ports

Hydraulic connections: see table 1.5 and point 7

NOTE: Intermediate flange and coupling are included. Refer to the table at point 8 for dimensions.

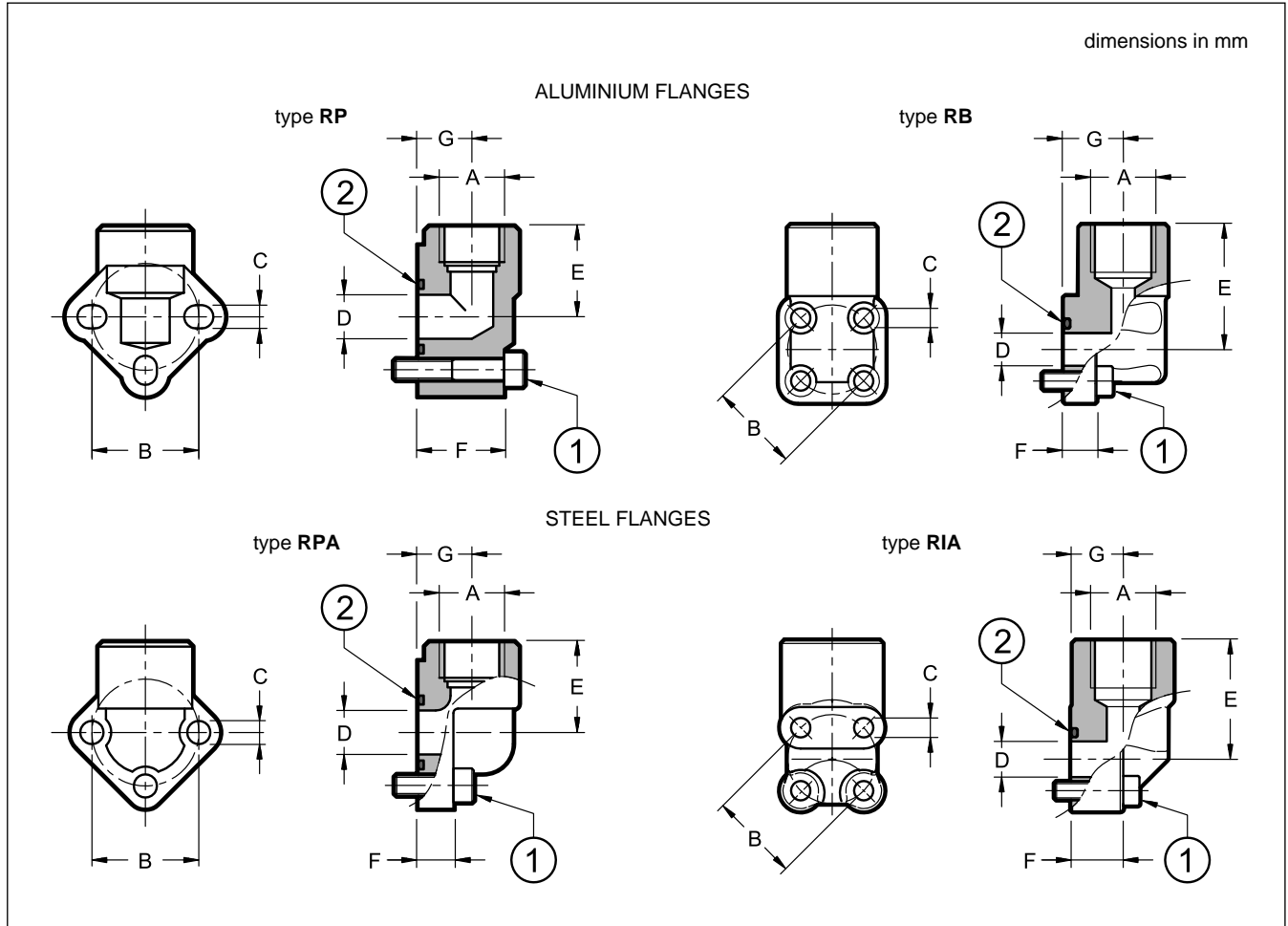
10 - CONNECTION FLANGES

ALUMINIUM FLANGES TYPE RB / RP

Fastening bolt and O-rings included

hydraulic connection ports (p. 7)	Flange code	Flange description	p max [bar]	ØA	B	C	ØD	E	F	G	(1) SHC bolts	(2)
FG2	21FL000417	RB038-30	180	3/8" BSP	30	6.5	11	42	11	20	n°2 - M6x30	OR 121 (15.88x2.62)
	21FL000418	RB012-30		1/2" BSP	30	6.5	11	42	11	20	n°2 - M6x45	
FE2	0610248	RP1-12		1/2" BSP	30	6.5	12.5	30	26	18	n°3 - M6x35	
FE3	0610249	RP2-34		3/4" BSP	40	8.5	18.5	40	31	20	n°3 - M8x45	OR 130 (22.22x2.62)
FE4	0610250	RP3-100		1" BSP	51÷56	10.5	25	46	43	26	n°3 - M10x60	OR 4118 (29.75x3.53)
FE5	0610251	RP35-114		1" ¼ BSP	62	13	32	57	17	33.5	n°3 - M12x35	OR 4143 (36.10x3.53)

STEEL FLANGES TYPE RPA / RIA (operating p max > 180 bar)

	Flange code	Flange description	p max [bar]	ØA	B	C	ØD	E	F	G	(1) SHC bolts	(2)
FG2	21FL000419	RIA30-038	315	3/8" BSP	30	6.5	12	40	17.5 32.5	17.5	n°2 - M6x20 n°2 - M6x35	OR 121 (15.88x2.62)
FG2	21FL000420	RIA30-012		1/2" BSP	30	7	12	40	17.5 32.5	17.5		
FE2	0771049	RPA1-12		1/2" BSP	30	7	12	27	10	21	n°3 - M6x20	
FE3	0770615	RPA2-34		3/4" BSP	40	8.5	20	36	11	21	n°3 - M8x25	OR 132 (23.81x2.62)
FE4	0770617	RPA3-100A		1" BSP	51	10.5	24	50	15	29	n°3 - M10x30	OR 4118 (29.75x3.53)



GPA*
SERIES 10

DUPLOMATIC
MOTION SOLUTIONS
*a member of **DAIKIN** group*

DUPLOMATIC MS Spa

via Mario Re Depaolini, 24 | 20015 Parabiago (MI) | Italy

T +39 0331 895111 | E vendite.ita@duplomatic.com | sales.exp@duplomatic.com

duplomaticmotionsolutions.com