

DL5B

SOLENOID OPERATED DIRECTIONAL VALVE COMPACT VERSION SERIES 10

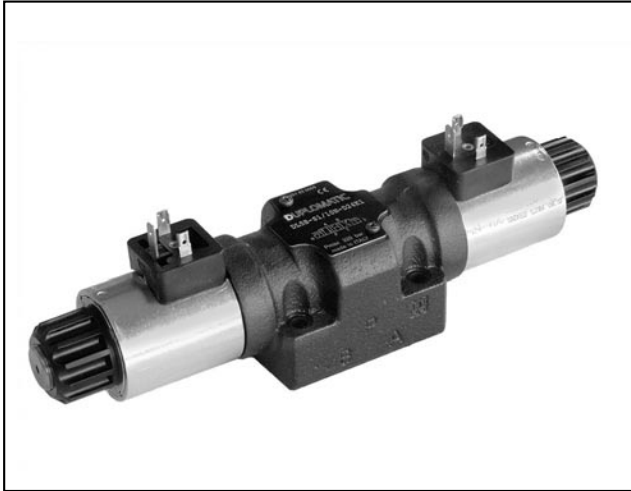

SUBPLATE MOUNTING ISO 4401-05

p max 320 bar
Q max 125 l/min

MOUNTING INTERFACE

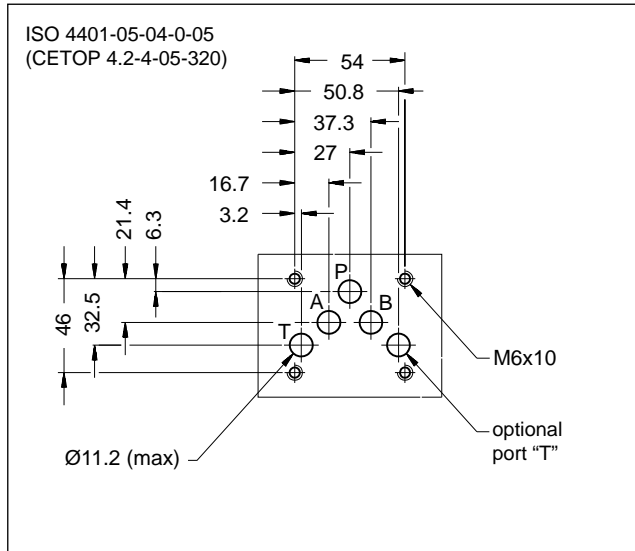

OPERATING PRINCIPLE

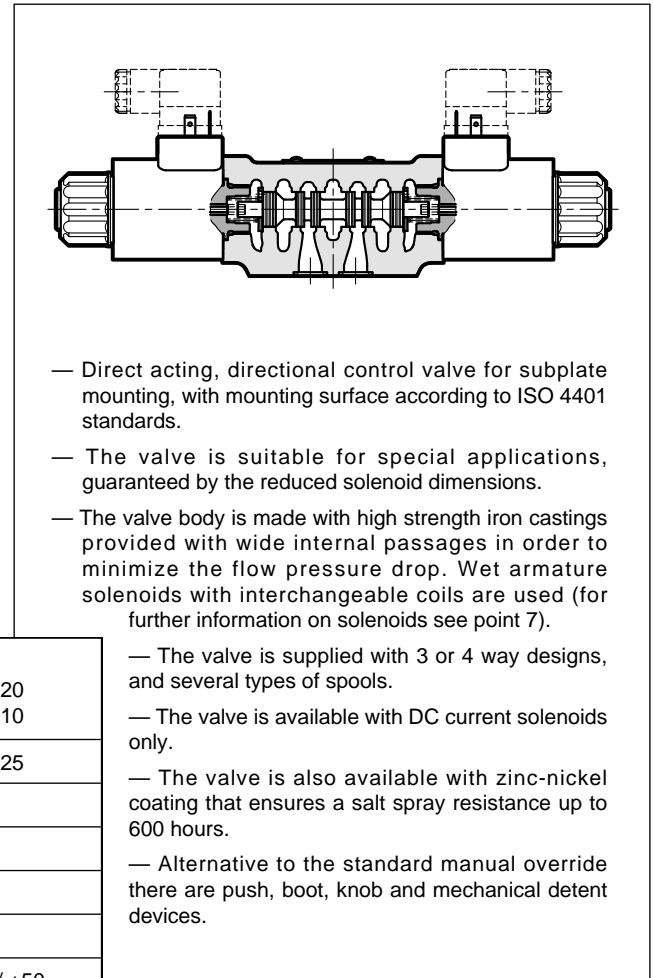

PERFORMANCES

(with mineral oil of viscosity of 36 cSt at 50°C)

Maximum operating pressure: - ports P - A - B - port T	bar	320 210
Maximum flow rate	l/min	125
Pressure drop $\Delta p-Q$	see point 4	
Operating limits	see point 6	
Electrical features	see point 7	
Electrical connections	see point 9	
Ambient temperature range	°C	-20 / +50
Fluid temperature range	°C	-20 / +80
Fluid viscosity range	cSt	10 ÷ 400
Fluid contamination degree	according to ISO 4406:1999 class 20/18/15	
Recommended viscosity	cSt	25
Mass: single solenoid valve double solenoid valve	kg	2.1 2.7



1 - IDENTIFICATION CODE

1.1 - Standard version

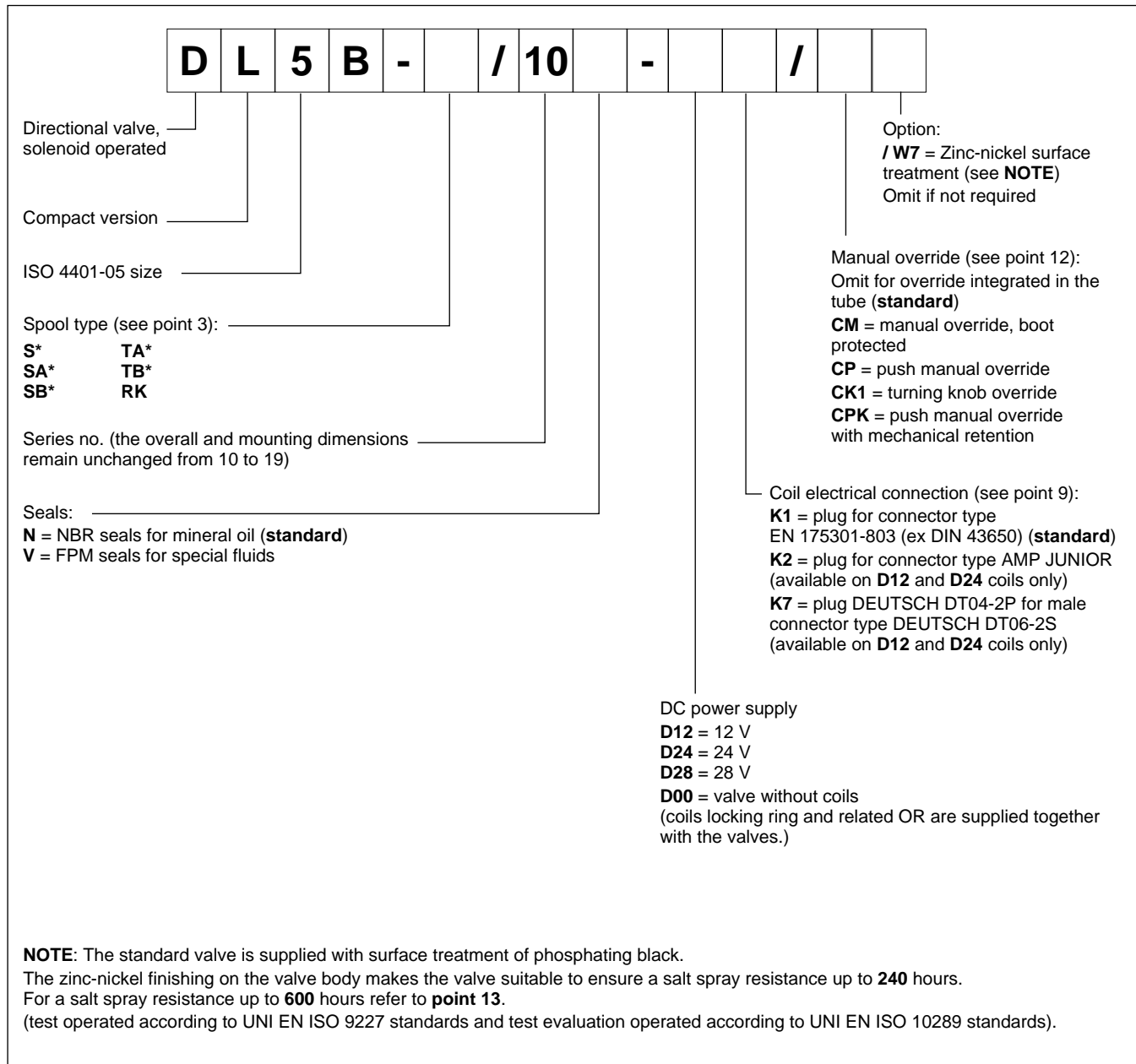

2 - HYDRAULIC FLUIDS

Use mineral oil-based hydraulic fluids HL or HM type, according to ISO 6743-4. For these fluids, use NBR seals (code N). For fluids HFDR type (phosphate esters) use FPM seals (code V). For the use of other fluid types such as HFA, HFB, HFC, please consult our technical department.

Using fluids at temperatures higher than 80 °C causes a faster degradation of the fluid and of the seals characteristics. The fluid must be preserved in its physical and chemical characteristics.

3 - SPOOL TYPE

Type S*:
2 solenoids - 3 positions
with spring centering

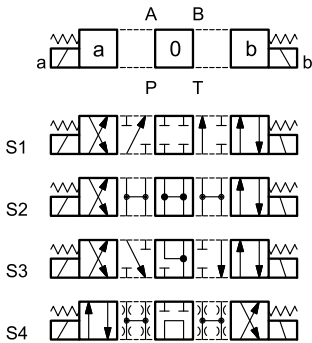

Type SA*:
1 solenoid side A
2 positions (central + external)
with spring return

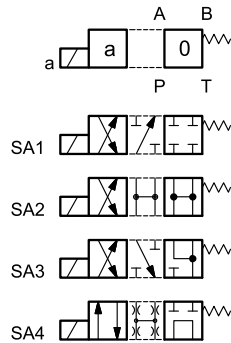

Type SB*:
1 solenoid side B
2 positions (central + external)
with spring return

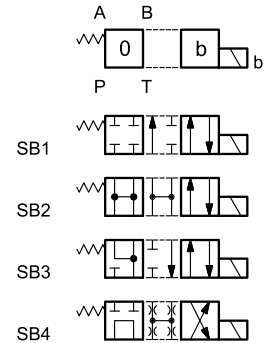

Type RK:
2 solenoids - 2 positions
with mechanical retention

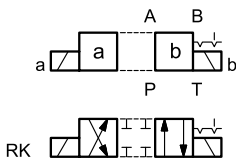

Type TA:
1 solenoid side A
2 external positions
with spring return

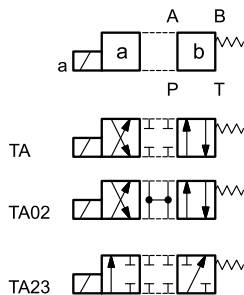

Type TB:
1 solenoid side B
2 external positions
with spring return

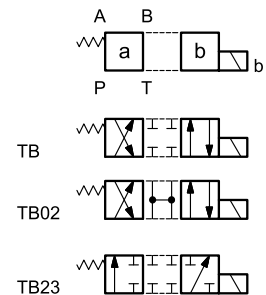

NOTE: Further spools available on request only.

4 - PRESSURE DROPS Δp -Q

(obtained with viscosity of 36 cSt at 50 °C)

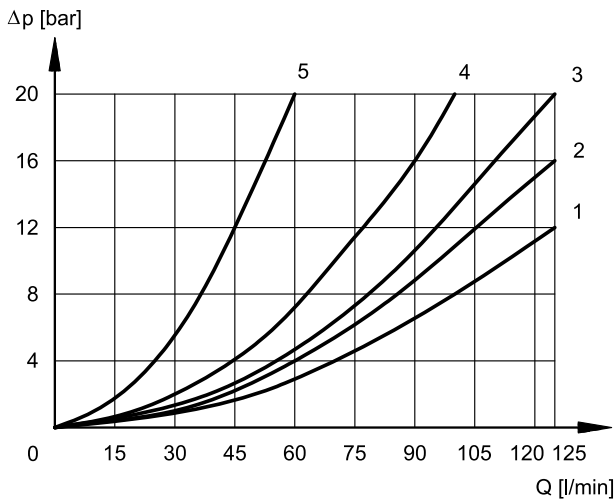

ENERGIZED VALVE

SPOOL	FLOW DIRECTIONS			
	P→A	P→B	A→T	B→T
	CURVES ON GRAPHS			
S1	1	1	2	2
S2	1	1	1	1
S3	1	1	1	1
S4	4	4	4	4
RK	2	2	2	2
TA	2	2	3	3
TA02	2	2	1	1
TA23	3	3	-	-

DE-ENERGIZED VALVE

SPOOL	FLOW DIRECTIONS		
	A→T	B→T	P→T
	CURVES ON GRAPHS		
S2	-	-	1
S3	5	5	-
S4	-	-	1

5 - SWITCHING TIMES

The values indicated are obtained with spool S1, according to ISO 6403 standard, with mineral oil viscosity 36 cSt at 50°C.

SUPPLY	TIMES ($\pm 10\%$) [ms]	
	ENERGIZING	DE-ENERGIZING
DC	70 ÷ 100	15 ÷ 20

6 - OPERATING LIMITS

The curves define the flow rate operating fields according to the valve pressure of the different versions. The values have been obtained according to ISO 6403 norm with solenoids at rated temperature and supplied with voltage equal to 90% of the nominal voltage. The values have been obtained with mineral oil, viscosity 36 cSt, temperature 50 °C and filtration according to ISO 4406:1999 class 18/16/13.

Limits of TA02 and TA spools refer to the 4-port operation. The operating limits of a 4-port valve that operates as 3-port valve, or with port A or B plugged or without flow, are shown in the chart on the next page.

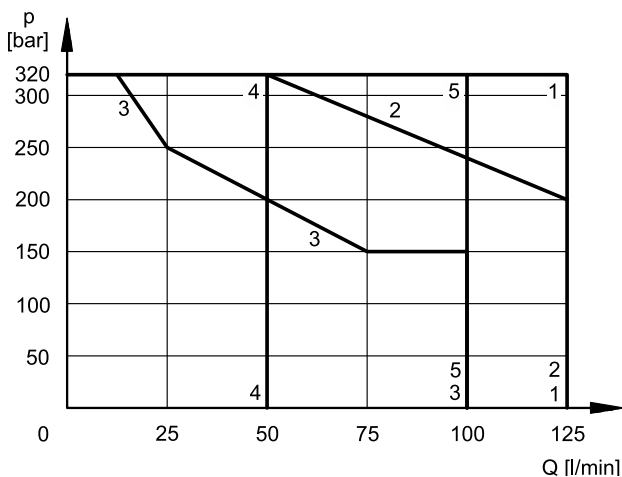

SPOOL	CURVE
S1, S2, RK	1
TA02	2
S3	3
S4	4
TA, TA23	5

6.1 - 4-port valve in 3-port operation

Operating limits of a 4-port valve in 3-port operation or with port A or B plugged or without flow.

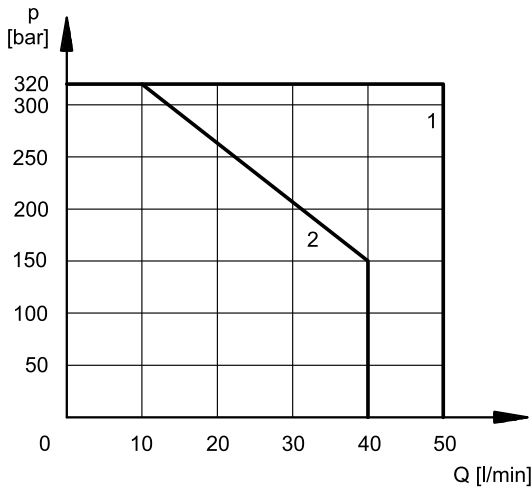

SPOOL	CURVE
TA	1
TA02	2

7 - ELECTRICAL FEATURES

7.1 - Solenoids

These are essentially made up of two parts: tube and coil. The tube is threaded into the valve body and includes the armature that moves immersed in oil, without wear. The inner part, in contact with the oil in the return line, ensures heat dissipation.

The coil is fastened to the tube by a threaded ring. The coils are interchangeable.

Protection from atmospheric agents IEC 60529

The IP protection degree is guaranteed only with both valve and connectors of an equivalent IP degree, correctly connected and installed.

electric connection	electric connection protection	whole valve protection
K1	IP65	IP65
K2	IP65/67	
K7	IP65/67	

SUPPLY VOLTAGE FLUCTUATION	± 10% Vnom
MAX SWITCH ON FREQUENCY	10.000 ins/hr
DUTY CYCLE	100%
ELECTROMAGNETIC COMPATIBILITY (EMC)	In compliance with 2014/30/EU
LOW VOLTAGE (NOTE)	In compliance with 2014/35/EU
CLASS OF PROTECTION Coil insulation (VDE 0580) Impregnation	class H class F

NOTE: In order to further reduce the emissions, use of type H connectors is recommended, because of they prevent voltage peaks at the opening of the coil supply electrical circuit (see cat. 49 000).

7.2 - Coils current and power consumption

The table below shows the consumption values relating to the various types of coils for direct current power supply.

Using connectors type 'D1' (see cat. 49 000) with embedded bridge rectifier it is possible to feed DC coils with alternating current (50 or 60 Hz), considering a reduction of the operating limits (see point 6).

(values ±10%)

	Nominal voltage [V]	Resistance at 20°C [Ω]	Current consumpt. [A]	Power consumpt. [W]	Coil code		
					K1	K2	K7
D12	12	4,4	2,72	32,7	1903080	1903100	1902940
D24	24	18,6	1,29	31	1903081	1903101	1902941
D28	28	26	1,11	31	1903082		-

8 - INSTALLATION

The configuration with centring and return springs can be mounted in any position.

Valve fitting takes place by means of screws or tie rods, fixing the valve on a lapped surface, with values of planarity and smoothness that are equal to or better than those indicated in the drawing. If the minimum values of planarity or smoothness are not met, fluid leakages between valve and mounting surface can easily occur.

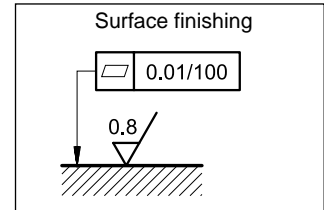

9 - ELECTRIC CONNECTIONS

connection for EN 175301-803
(ex DIN 43650) connector
code **K1** (standard)
code **WK1** (W7 version only)

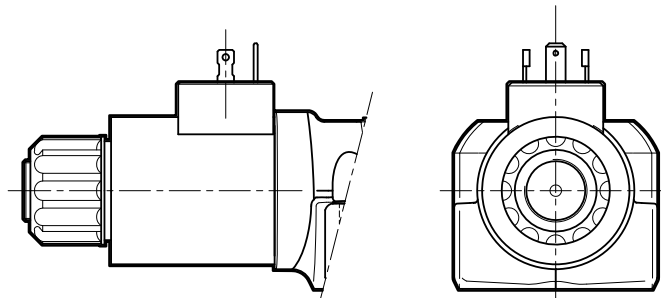

connection for AMP JUNIOR
connector
code **K2**

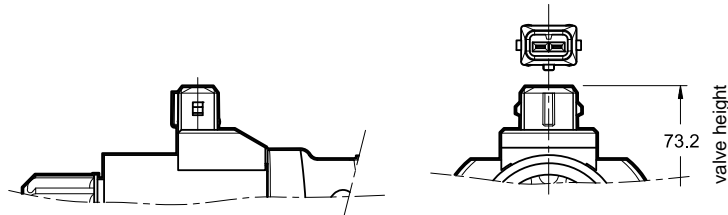

connection for
DEUTSCH DT06-2S male connector
code **K7**

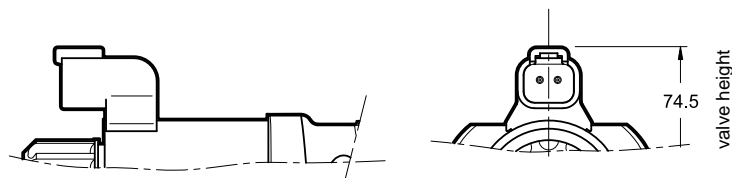

connection for
DEUTSCH DT06-2S male
connector
code **WK7** (W7 version only)
code **WK7D** (W7 version only - coil
with diode)

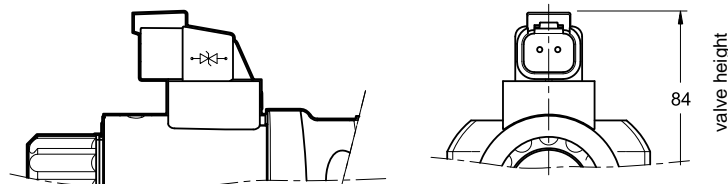

10 - ELECTRIC CONNECTORS

Solenoid operated valves are delivered without connectors. Connectors type EN 175301-803 (ex DIN 43650) for K1 and WK1 connections can be ordered separately. See catalogue 49 000.

11 - OVERALL AND MOUNTING DIMENSIONS

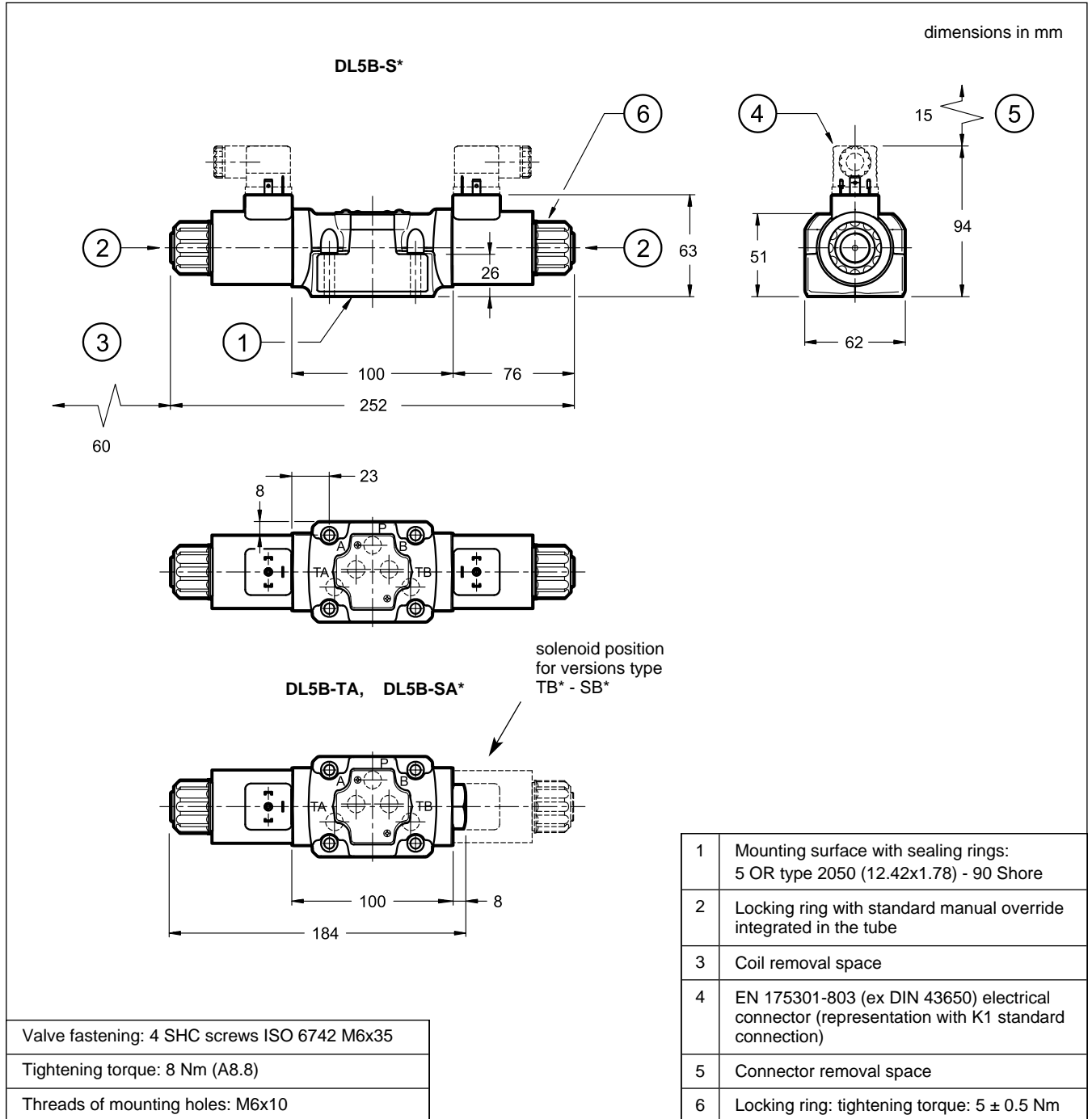

12 - MANUAL OVERRIDES

12.1 - CM Manual override, boot protected

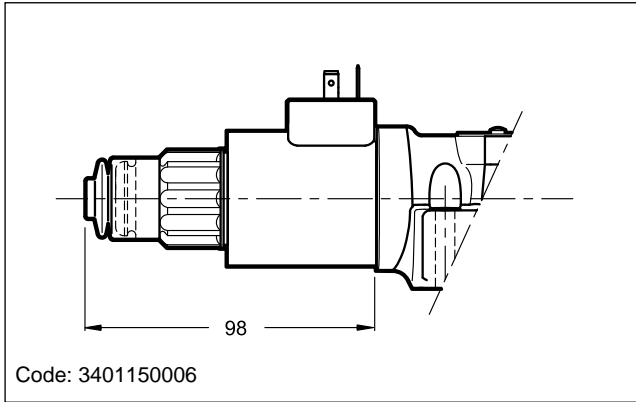

12.2 - CP Push manual override

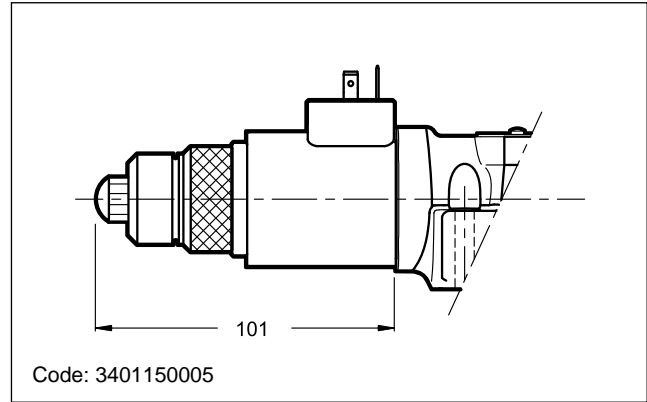

12.3 - CPK Push manual override with mechanical retention

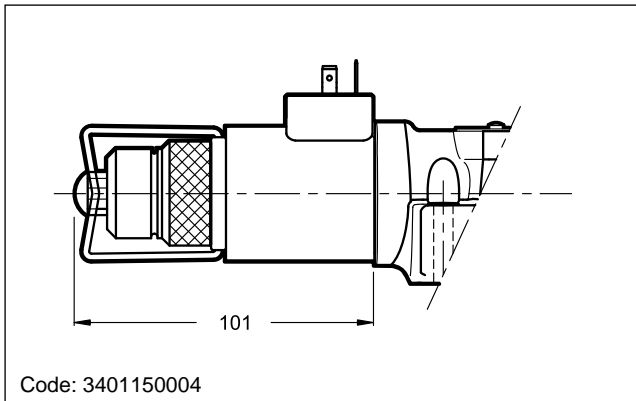

12.4 - CK1 Turning knob override

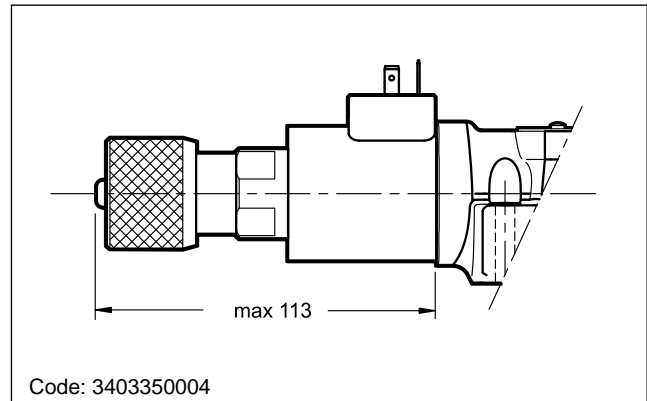

13 - HIGH IP AND CORROSION RESISTANCE VERSION

13.1 - Identification code

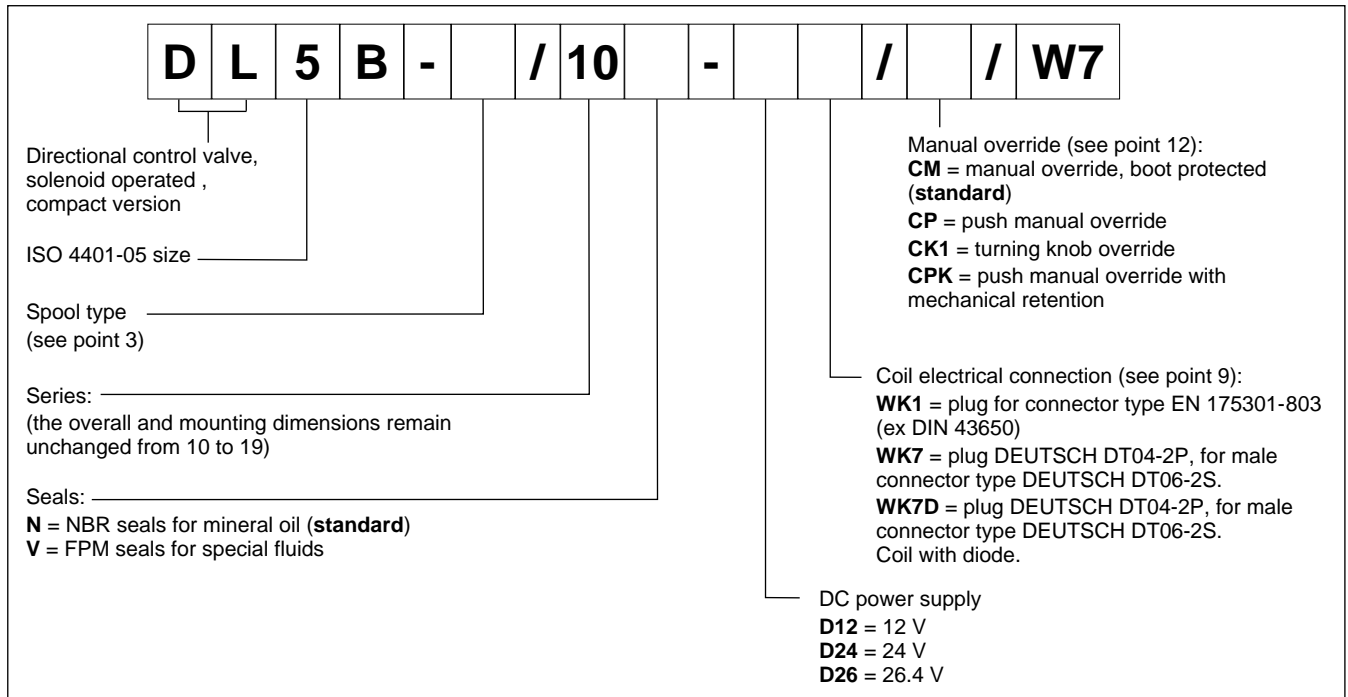

13.2 - Corrosion resistance

This version features the zinc-nickel coating on all exposed metal parts of the valve, making it resistant to exposure to the salt spray for **600** hours (test performed according to UNI EN ISO 9227 and assessment test performed according to UNI EN ISO 10289).

13.3 - DC coils

The coils feature a zinc-nickel surface treatment.

The WK7D coil includes a suppressor diode of pulses for protection from voltage peaks during switching. During the switching the diode significantly reduces the energy released by the winding, by limiting the voltage to 31.4V in the D12 coil and to 58.9 V in the D24 coil.

(values $\pm 10\%$)

	Nominal voltage [V]	Resistance at 20°C [Ω]	Current consumpt. [A]	Power consumpt. [W]	Coil code		
					WK1	WK7	WK7D
D12	12	4.4	2.72	32.7	3984000001	3984000101	3984000111
D24	24	18.6	1.29	31	3984000002	3984000102	3984000112
D26	26.4	21.8	1.21	32	3984000003	3984000103	-

13.4 - Protection from atmospheric agents IEC 60529

The IP protection degree is guaranteed only with both valve and connectors of an equivalent IP degree, correctly connected and installed.

electric connection	electric connection protection	whole valve protection
WK1	IP66	IP66
WK7	IP66/IP68/IP69 IP69K*	IP66/IP68/IP69 IP69K*
WK7D	IP66/IP68/IP69 IP69K*	IP66/IP68/IP69 IP69K*

(*) The IP69K protection degree is not taken into account in IEC 60529 but it is included in ISO 20653.

NOTE: As regards the liquid ingress protection (second digit), there are three means of protection.

Codes from 1 to 6 are related to water jets.

Rates 7 and 8 are related to immersion.

Rate 9 is reserved for high pressure and temperature water jets.

This means that IPX6 covers all the lower steps, rate IPX8 covers IPX7 but not IPX6 and lower, instead IPX9 does not cover any of them.

Whether a device meets two types of protection requirements it must be indicated by listing both the tests separated by a slash.

(E.g. a marking of an equipment covered both by temporary immersion and water jets is IP66/IP68).

14 - SPARE PARTS

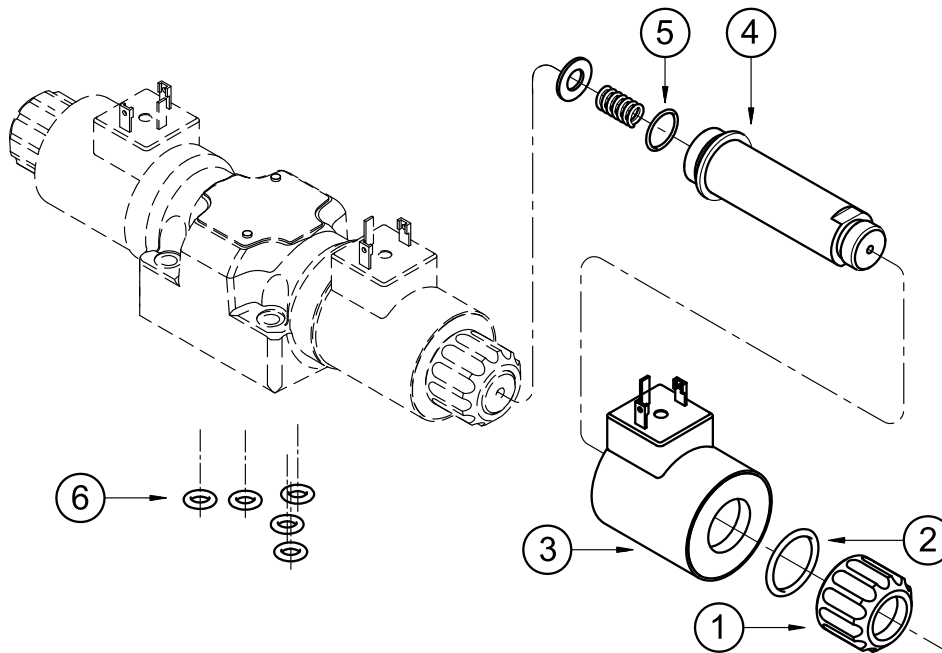

IDENTIFICATION CODE FOR DC COILS

C 22 S3 - /

Supply voltage

D12 = 12 V
D24 = 24 V
D26 = 26.4 V
D28 = 28 V

Series no.:

10 = for K7
11 = for K1 and K2
20 = for WK1, WK7 and WK7D

Coil electrical connection (see point 9):
K1 = plug for connector EN 175301-803 (ex DIN 43650)

for coils **D12**, **D24** and **D26**:

WK1 = plug for connector EN 175301-803 (ex DIN 43650)

WK7 = plug DEUTSCH DT04-2P, for male connector type DEUTSCH DT06-2S.

Only for **D12** and **D24**:

K2 = plug for connector AMP JUNIOR
K7 = plug DEUTSCH DT04-2P, for male connector type DEUTSCH DT06-2S.

WK7D = plug DEUTSCH DT04-2P, for male connector type DEUTSCH DT06-2S.
 Coil with diode.

1	Coil locking ring - code 0119412 tightening torque: 5 ±0.5 Nm
2	ORM-0220-20 - 70 shore
3	Coil (see identification code)
4	Solenoid tube: TDM22-DL5/10N (NBR seals) TDM22-DL5/10V (FPM seals) (OR n° 5 included)
5	OR type 3.910 (19.18x2.46) - 70 shore
6	N. 5 OR type 2050 (12.42x1.78) - 90 Shore

SEAL KIT

The codes included the OR n° 2, 5, 6 and 7.

Cod. 1985461 NBR seals

Cod. 1985462 FPM seals

NOTE: You can also order coils using the coil codes at points 7.2 and 13.3.

15 - SUBPLATES

(See catalogue 51 000)

Type PMD4-AL4G with rear ports - threading: 3/4" BSP

Type PMD4-AL4G with side ports - threading: 1/2" BSP

DIPLOMATIC
 MOTION SOLUTIONS
 a member of **DAIKIN** group

DIPLOMATIC MS Spa

via Mario Re Depaolini, 24 | 20015 Parabiago (MI) | Italy

T +39 0331 895111 | E vendite.ita@duplomatic.com | sales.exp@duplomatic.com

duplomaticmotionsolutions.com